

# MAGNETS

HOLDING • LIFTING • FIXTURING • FABRICATION • WELDING AND MORE



**Making Things Better®**

MAGNETS, METALWORKING & MATERIAL HANDLING CATALOG - 101W

# CUSTOM MAGNETIC LIFTING SPECIALISTS



**Making Things Better®**

Our factory experts will develop a unique magnetic lifting device if a standard magnetic lift doesn't work for your application. We will be there every step of the way from field sales support to design, manufacturing and final testing.

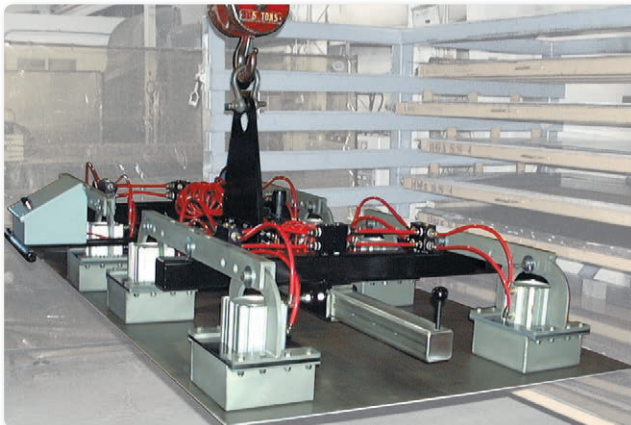
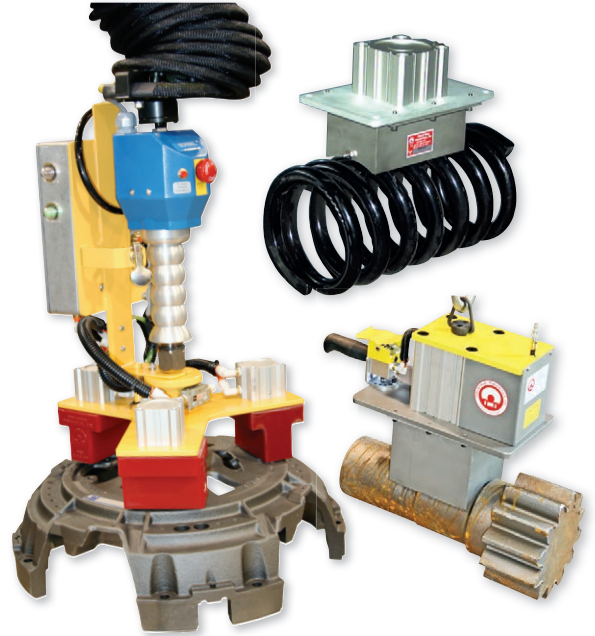

For more information on our custom lifting products, please contact us today at 888.582.0823 or go online to [www.magnetics.com](http://www.magnetics.com)

## ■ WHO WE ARE

---

IMI is an industry leader in providing both permanent magnets and electromagnets for work holding, lifting, fixturing, conveying and magnetic separation.

At IMI, our specialty is custom fabricating! We design, engineer and manufacture magnetic assemblies and magnetic separation devices for our customers' specific requirements, and take pride in the quality and performance of our products.

With worldwide distribution through a combination of a direct sales force and manufacturers representatives, we strive to provide personalized service and innovative solutions to meet the exact needs of your application.

THREE PRODUCT GROUPS, ONE GOAL...the right product for the application at the right time for our customer



IMI is proud to be a United States - based manufacturer of magnetic assemblies and our USA M.A.D.E™ logo is how we like to show it. You will find our USA M.A.D.E™ logo on any of our products that are **Manufactured • Assembled • Designed • Engineered** here, in the USA, at our facilities.

## ■ TABLE OF CONTENTS

---

Magnet Basics & Safety Information .....	4
Lift Magnet Basics & Safety Information.....	5
Raw Magnet Material / Max-Attach™ .....	6-7
Cylindrical Fixture Magnet Assemblies .....	8
Cup Magnet Assemblies .....	9
Tube Clamps & Door Stops/Latches .....	10
Rectangular Fixture Magnet Assemblies .....	11
Magnetic Jigs, Strips & Sheets.....	12
Magnets For Holding & Sweeping .....	13
Magnets For Capturing Metal In Liquids.....	14
Magnetic Retrievers & Mechanical Fingers .....	15
Inspection Mirrors .....	16
Inspection Kits & Retrievers .....	17
Welding Angles & Clamping Devices .....	18
Welding Squares, Grounds & Tools .....	19
Magnets for Holding & Storage .....	20-21
Tool Storage & Squaring Arms .....	22
Cutting Table Tools & Retrievers .....	23
Permanent Ceramic Magnetic Lifts .....	24
Permanent Rare Earth Magnetic Lifts .....	25-26
Lift Magnets.....	27
Lift Magnets & Accessories .....	28
Lift Magnet Accessories.....	29
Manhole Cover Lift Products .....	30-31
Electro Magnets & Counter Wheels .....	32
Demagnetizers .....	33
Automotive & Appliance Tools .....	34
Automotive, Appliance Tools & Clamps .....	35
Fanners for Sheet Separation.....	36-37
Transporters® & End of Arm Tooling .....	38-39
Sheet Lift Systems .....	40
Tube Lifters & Palletizers/Depalletizers .....	41
Conveyors & Conveyor Components .....	42-43

# MAGNET BASICS & SAFETY INFORMATION

## ■ Magnet Materials

---

**Flexible** magnetic strips are made of a Ferro-Magnetic powder with a polymer bonding. These **low** energy strips resist demagnetization and will not chip, crack or shatter. Flexible magnets form to any contour and are often used for labeling or advertising purposes. Flexible magnets can be cut, drilled or shaped. Maximum temperature 160°F (70°C).

**Ceramic** magnets are made of Strontium Ferrite (SrFe) in a sintering process. Ceramic magnets are staples in the electronic, automotive, medical, mining, oil industries, etc. Ceramic magnets are **medium strength** magnet material with a high resistance to demagnetization, long time stability (loses 0.5% of its magnetic strength in 100 years), brittle material that has to be cut with diamond tipped blades. Temperature range -148°F (-60°C) to 480°F (249°C).

**Alnico** magnets are made of Aluminum, Nickel and Cobalt (AlNiCo) in either a casting or sintering process. Used in application environments that have **high heat**, Alnico magnets offer **medium strength** and the best temperature characteristics of any standard magnet material. Alnico magnets have a medium resistance to demagnetization and are very hard and brittle. Machining or drilling cannot be accomplished by ordinary means. Temperature range -167°F (-75°C) to 800°F (427°C).

**Rare Earth Neodymium-Iron-Boron (NdFeB)** magnets are made in sintered as well as bonded forms. Commonly referred to as Neo, this magnet material provides the **highest magnetic strength** of any magnet material, very high resistance to demagnetization and is ideal for applications requiring maximum strength in a limited area. Neo is usually coated or plated to prevent oxidation due to its high iron content and therefore grinding of Neo material must be avoided. Temperature range -302°F (-150°C) to 180°F (82°C).

**Rare Earth Samarium Cobalt (SmCo)** magnets are made in a sintering process. Samarium Cobalt has the **highest magnetic strength** combined with **high temperature range** making it ideal for applications requiring very high strength in hot environments. Temperature range -302°F (-150°C) to 392°F (200°C).

## ■ Magnet Safety Factors

---

Our magnetic material meets Magnetic Materials Producers Association (MMPA) standards for physical quality and magnetic properties. Some magnetic material is brittle in nature and minor defects such as chips and hairline cracks are unavoidable.

When selecting a magnet for your application, consider the physical shape of the part (round, convex, concave, etc.) and the surface condition (rough, rusty, dirty, oily). Both can result in air gaps\* between the contact points on the magnet & the work material, thereby reducing the magnetic power. These factors and the information in this catalog will aid in choosing the correct magnet for your application. If you have specific questions, our application experts can help you select the right magnet material for your application requirements.

- Work surface
- Temperature
- Direction of magnetization
- Finish
- Part size, thickness and weight
- Material - Ferrous or non-ferrous
- Gauss
- Contact area between magnet & part
- Continuous or intermittent operation
- Tolerance

\*Air gap - The air, protective coating, paint, galvanizing, oil, rust, dirt, etc. between the magnet and the part.

## ■ Loss of Magnetism

---

Under normal use conditions, a permanent magnet can experience a decrease in its original holding value. The most common factors which can cause a loss of strength include:

- Every day wear and tear on the magnet face.
- Exposure to extreme temperatures outside the magnet's temperature range.
- Severe blow or shock to the magnet. Do not use a blunt instrument to position the magnet on the load.
- Exposure to electrical currents. Never place the magnet next to a large motor or generator. Never use the magnet as part of a welding ground circuit.
- Exposure to vibration.

# LIFT MAGNET BASICS & SAFETY INFORMATION

## ■ Lift Magnet Safety Factors

Lift magnets can be effective even when the surfaces of the magnet and/or load have dirt, paint, scale or other debris on them. However, the best efficiency of any magnetic lift is achieved when these surfaces are clean and the poles of the lift (the surfaces in contact with the load) have good, uninterrupted contact with the load.

### It is therefore recommended to:

Avoid setting down the lift in places on the load that are dirty or have rough surface texture. Clear any foreign material from the load before setting the lift on it. Occasionally check the mechanical condition of the magnetic poles to make sure they are flat and have not been damaged during use. After using the lift, protect the pole surfaces with oil. This will keep the steel surface from rusting.

## ■ Material Surface & Safe Lifting Conditions

Lifting ferrous items using a magnet requires a good look at the length, width and thickness of the item. Thin metals do not absorb as many of the magnetic flux lines (magnetic energy) as thicker metals. Thin metals also flex, causing the steel to peel-off the magnet. Equally important is the physical size, flatness, surface conditions and type of steel. The charts below illustrate how surface finish and Carbon content effect lifting value.

PERCENTAGE OF STATED LIFTING POWER BY MATERIAL

CARBON CONTENT	LOW CARBON 0.05 - 0.29%	100%
	MODERATE CARBON 0.30 - 0.59%	85%
	HIGH CARBON 0.60 - 0.99%	75%
	HIGHER CARBON = HIGHER RESIDUAL*	

PERCENTAGE OF STATED LIFTING POWER BY SURFACE FINISH

SURFACE FINISH	GROUND SURFACE	100%
	ROUGH MACHINED	100%
	FOUNDRY FINISH	85%
	ROUGH CAST	65%

\* HIGH CARBON STEEL (TOOL STEEL) WILL ABSORB MAGNETISM & MAY MAGNETICALLY STICK TO STEEL SURFACES, SUCH AS THE MAGNET, OR ATTRACT FERROUS PARTICLES.

## ■ Design Factor

**Design factor is the relation of the magnet's labeled working load limit (WLL) compared to the magnet's maximum lifting value under ideal conditions.** Ideal conditions are when a magnet is new and pulled off a newly machined, thick, low carbon steel plate. **The pounds of pull it takes to break the magnet away from the steel surface is the "maximum" lifting value.**

 Unless otherwise noted, magnet working load limits are stated up to 50% of the actual value. These magnets may reach substantially higher holding values, but the surface condition of the part may affect the magnet's performance capabilities.

Working load limit (de-rating) values are then determined by taking this maximum lifting value and dividing it by the manufacturers' design factor. Design factors are minimum 2:1 and most cases 3:1. This means a magnet with a 3:1 design factor and labeled with a working load limit of 1,000 lbs will have a break-a-way force minimum of 3,000 lbs. The labeled WLL is stated for the benefit and safety of the user, due to the fact that ideal conditions rarely exist in the field. The steel that you are lifting may have scale, rust, dirt, or coatings on its surface; or the surface of the magnet itself may be worn. Any of these conditions will cause lower lifting values. Pick a lift magnet that has a WLL value slightly higher than the weight of your part.

**DO NOT ADD** additional weight to your lifting requirements. If you have a 1,000 lb part and you buy a higher labeled 2,000 lb lift magnet, it will result in a magnet that is much heavier, harder to handle and cost more than needed since the 2,000 lb magnet should have a Design Factor of 2:1 or 3:1. **Under no circumstances should you lift ferrous objects that weigh more than the stated working load limit value.**

## ■ ASME B30.20 Lifting Standards & ASME BTH-1 Design Standard

The American Society of Mechanical Engineers has established standards for Below-the-Hook Lifting Devices. This standard applies to the marking, construction, installation, inspection, testing, maintenance, and operation of all lifting magnets when used for single or multiple steel piece handling operations in which the operator of the lifting magnet is required to manually position the lifting magnet on the load and manually guide the load during its movement, or in close proximity to people.

Lifting devices designed to this Standard shall comply with ASME B30.20, Below-the-Hook Lifting Devices. Designed and manufactured to ASME BTH-1 Standard.

**Industrial Magnetics, Inc. offers several lift magnet options that conform to the ASME B30.20 standards**

# RAW MAGNET MATERIAL



## Alnico Magnet Material

Alnico magnets are made of Aluminum, Nickel and Cobalt (AlNiCo) offer **medium strength** and the best temperature characteristics of any standard magnet material. Alnico magnets have a medium resistance to demagnetization and are very hard and brittle. Machining or drilling cannot be accomplished by ordinary means.

### Alnico Features

- Ideal for high heat applications
- Alnico 5 Magnet Material
- Maximum temperature 800°F (427°C)
- Tolerance ±0.005" on all dimensions

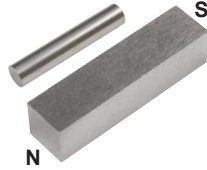

### Alnico Rectangular Material

Hold - lbs (kg)	Th. (in)	Wd. (in)	Ln. (in)	Wt. (lbs)	Model No.
0.75 (0.34)	0.25	0.25	1.00	0.01	ABAR025X025X100
2.0 (0.90)	0.375	0.375	1.50	0.05	ABAR037X037X150
4.5 (2.04)	0.50	0.50	2.00	0.15	ABAR050X050X200

### Alnico Cylindrical Material

Hold - lbs (kg)	Dia. (in)	Ln. (in)	Wt. (lbs)	Model No.
0.75 (0.34)	0.1875	1.00	0.01	A5RC018X100
1.125 (0.51)	0.250	2.00	0.05	A5RC025X200
3.0 (1.36)	0.375	2.00	0.05	A5RC037X200
4.0 (1.81)	0.500	3.00	0.15	A5RC050X300
6.0 (2.72)	0.875	3.00	0.50	A5RC087X300

## Alnico Rotor Magnets



### Alnico Rotor Magnet Features

- Constructed for difficult holding applications
- Especially effective on thin metal applications
- Heat resistance up to 800°F (427°C)
- Alnico 5 magnet material

### Alnico Rotor Magnets

Hold - lbs	A (in)	B (in)	C (in)	D (in)	E (in)	Wt. (lbs)	No. of Poles	Model No.
16	1.00	0.75	0.50	0.26	0.25	0.10	4	5X11B
25	1.25	0.75	0.63	0.26	0.25	0.16	6	5H177
70	2.00	1.25	0.90	0.50	0.38	0.70	8	5X13B

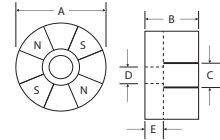

## Ceramic Magnet Material

Ceramic magnets are a non-metallic, non-conductive, hard, brittle material compound of iron oxide, Strontium Ferrite and small quantities of other metal oxides that can only be cut with a diamond wheel.

### Ceramic Features

- Low cost, high energy material
- Performs best at temperatures below 480°F (249°C)
- Difficult to grind or drill, cannot be machined utilizing EDM
- Tolerance ±2% on O.D., Length & Width. ±.005" on Thickness



### Ceramic Disc Material

Hold - lbs (kg)	Dia. (in)	Ln. (in)	Wt. (lbs)	Grade	Model No.
4.24 (1.92)	0.875	1.000	0.11	5	7/8DIA X 1C5

### Ceramic Ring Material

Hold - lbs (kg)	O.D. (in)	I.D. (in)	Ln. (in)	Wt. (lbs)	Grade	Model No.
0.36 (0.16)	0.750	0.271	0.250	0.022	8	F1409
0.75 (0.34)	1.230	0.885	0.431	0.044	8	F1407
3.5 (1.58)	1.723	1.205	0.250	0.082	8	F1405
9.5 (4.31)	2.800	1.203	0.590	0.466	8	710006
5.5 (2.49)	2.825	1.250	0.330	0.600	8	431005
20.5 (9.30)	5.250	2.312	0.750	2.408	8	455005

### Ceramic Rectangular Material

Hold - lbs (kg)	Th. (in)	Wd. (in)	Ln. (in)	Wt. (lbs)	Grade	Model No.
6.0 (2.72)	0.375	0.875	1.875	0.11	8	5C458
5.0 (2.26)	0.250	1	2	0.10	8	250X1X2C8
7.0 (3.17)	0.500	1	2	0.15	8	500X1X2C8
9.0 (4.08)	0.750	1	2	0.25	8	750X1X2C8
11.0 (4.99)	1.000	1	2	0.35	8	1X1X2C8
15.0 (6.80)	1.000	2	2	0.70	8	1X2X2C8
6.5 (2.95)	0.187	4	4	0.75	8	187X4X4C5
8.5 (3.85)	0.250	4	4	1.00	8	250X4X6C5
8.0 (3.62)	0.312	4	4	0.83	8	312X4X4C5
10.5 (4.76)	0.375	4	4	1.00	8	375X4X4C5
14.0 (6.35)	0.500	4	6	2.00	8	500X4X6C8
18.5 (8.39)	0.750	4	6	3.00	8	750X4X6C5
23.5 (10.66)	1.000	4	6	4.00	8	1X4X6C8

## Rare Earth Magnet Material

Rare Earth Neodymium-Iron-Boron (NdFeB) magnets are commonly referred to as Neo. This magnet material provides the **highest magnetic strength** of any magnet material, very high resistance to demagnetization and is ideal for applications requiring maximum strength in a limited area. Neo is usually coated or plated to prevent oxidization, therefore, avoid grinding.

### Neodymium Features

- Extremely powerful magnet
- Ideal for miniaturized applications
- Operates best at temperatures below 180°F (82°C)
- High resistance to demagnetization
- Nickel plated finish
- Tolerance ±0.005" on all dimensions

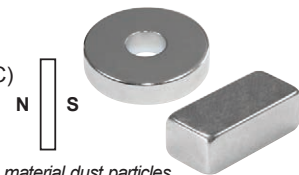

**NOTE:** Avoid grinding, as flash fires may occur from rare earth material dust particles. Crystalline structured material is easily chipped, cracked or broken.

### Rare Earth Ring Material

O.D. (in)	I.D. (in)	Ln. (in)	Wt. (lbs)	Hold - lbs (kg)	Model No.	Hold - lbs (kg)	Model No.
0.250	0.060	0.060	0.0002	0.2 (0.09)	NE250060060NP35	-	-
0.365	0.200	0.250	0.001	4.2 (1.91)	NE365200250NP35	-	-
0.375	0.136	0.100	0.001	2.0 (0.90)	NE375136100NP35	-	-
0.750	0.125	0.125	0.600	-	-	9.63 (4.37)	NE751212NP42
0.750	Counter Sink #8 Screw	0.125	0.600	-	-	8.60 (3.90)	NE7512CSNP42
1.000	Counter Sink #8 Screw	0.125	0.800	-	-	12.6 (5.72)	NE10012CSNP42
0.875	0.275	0.200	0.050	19.0 (8.62)	NE875275200NP35	-	-
1.000	0.1975	0.125	0.070	-	-	12.39 (5.62)	NE101912NP42
1.500	0.125	0.125	0.080	-	-	20.28 (9.20)	NE151212NP42

### Rare Earth Rectangular Material

Th. (in)	Wd. (in)	Ln. (in)	Wt. (lbs)	Hold - lbs (kg)	Model No.	Hold - lbs (kg)	Model No.
0.187	1.000	1.500	0.100	-	-	34.0 (15.42)	NEO 3/16 RECTNP
0.1875	1.000	1.500	0.100	-	-	28.0 (12.70)	NE181510NP42
0.250	0.500	2.000	0.070	21.0 (9.53)	NE2550200NP35	-	-
0.250	1.000	2.000	0.140	30.0 (13.61)	NE25100200NP35	-	-
0.340	0.250	0.750	0.018	6.0 (2.72)	NE342575NP35	-	-

### Rare Earth Square Material

Th. (in)	Wd. (in)	Ln. (in)	Wt. (lbs)	Hold - lbs (kg)	Model No.	Hold - lbs (kg)	Model No.
0.100	0.250	0.250	0.001	4.25 (1.93)	NE012525NP35	-	-
0.125	0.500	0.500	0.009	-	-	9.0 (4.08)	NE010505NP42
0.125	0.500	1.000	0.018	-	-	12.8 (5.81)	NE010510NP42
0.500	0.500	0.500	0.030	18.0 (8.16)	NE505050NP35	-	-
0.125	1.000	1.000	0.034	-	-	18.0 (8.16)	NE011010NP42
0.125	1.500	1.500	0.076	-	-	28.0 (12.70)	NE011515NP42
0.250	0.750	0.750	0.040	16.0 (7.26)	NE257575NP35	-	-
0.500	1.000	1.000	0.030	45.0 (20.41)	NE50100100NP35	-	-

## Rare Earth Magnet Material (continued)

### Rare Earth Cylindrical Material

Dia. (in)	Ln. (in)	Wt. (lbs)	35 MgO		42 MgO		52 MgO	
			Hold - lbs (kg)	Model No.	Hold - lbs (kg)	Model No.	Hold - lbs (kg)	Model No.
0.120	0.060	0.0002	0.2 (0.09)	NE1206NP35	-	-	-	-
0.120	0.250	0.0002	0.3 (0.13)	NE1225NP35	-	-	-	-
0.120	0.500	0.0004	0.6 (0.27)	NE1250NP35	-	-	-	-
0.187	0.060	0.0004	0.6 (0.27)	NE1806NP35	-	-	-	-
0.220	0.100	0.001	1.0 (0.45)	NE2210NP35	-	-	-	-
0.220	0.250	0.003	1.5 (0.68)	NE2225NP35	-	-	-	-
0.220	0.500	0.007	1.8 (0.81)	NE2250NP35	-	-	-	-
0.250	0.100	0.001	1.0 (0.45)	NE2510NP35	-	-	-	-
0.250	0.125	0.002	1.2 (0.54)	NE2512NP35	2.3 (1.04)	NE2512NP42	-	-
0.250	0.187	0.002	1.5 (0.68)	NE2518NP35	-	-	-	-
0.250	0.200	0.003	1.7 (0.77)	NE2520NP35	3.07 (1.39)	NE2520NP42	-	-
0.250	0.250	0.003	1.8 (0.81)	NE2525NP35	3.35 (1.52)	NE2525NP42	-	-
0.250	0.500	0.007	2.1 (0.95)	NE2550NP35	3.87 (1.76)	NE2550NP42	-	-
0.310	0.060	0.006	1.3 (0.59)	NE3106NP35	-	-	-	-
0.320	0.250	0.006	3.1 (1.40)	NE3225NP35	-	-	-	-
0.375	0.060	0.002	1.6 (0.73)	NE3706NP35	-	-	-	-
0.375	0.100	0.003	2.0 (0.90)	NE3710NP35	-	-	-	-
0.375	0.125	0.004	2.6 (1.18)	NE3712NP35	-	-	-	-
0.375	0.187	0.006	4.5 (2.04)	NE3718NP35	-	-	-	-
0.375	0.200	0.006	4.5 (2.04)	NE3720NP35	-	-	-	-
0.375	0.250	0.007	4.6 (2.08)	NE3725NP35	6.86 (3.11)	NE3725NP42	-	-
0.375	0.375	0.011	5.7 (2.58)	NE3737NP35	7.96 (3.61)	NE3737NP42	-	-
0.375	0.500	0.015	6.7 (3.04)	NE3750NP35	8.5 (3.86)	NE3750NP42	10.5 (4.76)	NE3750NP52
0.500	0.060	0.003	3.0 (1.36)	NE5006NP35	-	-	3.8 (1.72)	NE5006NP52
0.500	0.125	0.007	4.0 (1.81)	NE5012NP35	6.08 (2.76)	NE5012NP42	7.90 (3.58)	NE5012NP52
0.500	0.187	0.010	5.7 (2.58)	NE5018NP35	-	-	-	-
0.500	0.200	0.010	6.0 (2.72)	NE5020NP35	9.49 (4.30)	NE5020NP42	11.7 (5.31)	NE5020NP52
0.500	0.250	0.013	6.5 (2.94)	NE5025NP35	10.88 (4.94)	NE5025NP42	13.4 (6.08)	NE5025NP52
0.500	0.375	0.020	8.9 (4.03)	NE5037NP35	-	-	-	-
0.500	0.500	0.026	11.2 (5.08)	NE5050NP35	14.66 (6.65)	NE5050NP42	18.0 (8.16)	NE5050NP52
0.750	0.060	0.020	3.2 (1.45)	NE7506NP35	4.95 (2.25)	NE7506NP42	-	-
0.750	0.125	0.060	-	-	9.76 (4.43)	NE7512NP42	-	-
0.750	0.187	0.060	20.0 (9.07)	NE7518NP35	-	-	-	-
0.750	0.250	0.026	10.7 (4.76)	NE7525NP35	-	-	-	-
0.750	0.375	0.030	13.5 (6.12)	NE7537NP35	24.0 (10.89)	NE7537NP42	29.7 (13.47)	NE7537NP52
0.750	0.500	0.045	22.0 (9.98)	NE7550NP35	-	-	-	-
1.000	0.062	0.013	-	-	6.80 (3.08)	NE10006NP42	8.40 (3.81)	NE10006NP52
1.000	0.125	0.028	-	-	12.60 (5.72)	NE10012NP42	15.6 (7.08)	NE10012NP52
1.000	0.187	0.040	-	-	22.45 (10.18)	NE10018NP42	27.8 (12.61)	NE10018NP52
1.500	0.125	0.070	-	-	20.37 (9.24)	NE15012NP42	25.0 (11.34)	NE15012NP52

## Max-Attach™ Rare Earth Magnet Material

### Rare Earth Max-Attach™

Hold - lbs (kg)	Outer Dia. (in)	Inner Dia. (in)	Thick. (in)	Wt. (lbs)	Model No.
<b>Disc</b>					
7.7 (3.52)	0.500	-	0.125	0.007	CMP5012P1N35
9.3 (4.22)	0.500	-	0.187	0.037	CMP5018P2N35
8.8 (3.99)	0.500	-	0.125	0.007	CMP5012P1N42
10.5 (4.76)	0.500	-	0.187	0.037	CMP5018P2N42
15.3 (6.94)	0.750	-	0.062	0.007	CMP7506P1N42
18.0 (8.16)	0.750	-	0.125	0.015	CMP7512P1N42
16.5 (7.48)	1.000	-	0.062	0.013	CMP10006P1N42
37.3 (16.92)	1.000	-	0.125	0.027	CMP10012P1N42
38.4 (17.42)	1.000	-	0.187	0.040	CMP10018P2N42
77.0 (34.93)	1.500	-	0.125	0.060	CMP15012P1N42
<b>Ring</b>					
16.3 (7.39)	0.750	0.125	0.125	0.014	CMP751212P2N42
11.0 (4.99)	0.750	#6CS	0.125	0.011	CMP7512CSP2N42
17.0 (7.71)	1.000	#6CS	0.125	0.800	CMP1002CSP2N42
33.2 (15.06)	1.000	0.190	0.125	0.026	CMP101912P2N42
67.3 (30.53)	1.500	0.125	0.125	0.059	CMP151212P2N42
119.0 (53.98)	2.000	0.875	0.187	0.128	CMP208718P2N42
<b>Rectangle</b>					
26 (11.79)	1.000	1.000	0.06	0.018	CMP061010P2N50
39.8 (18.05)	1.000	1.000	0.125	0.034	CMP011010P1N42
13.1 (5.94)	0.500	0.500	0.125	0.008	CMP010505P1N42
17.1 (7.76)	1.000	0.500	0.125	0.017	CMP010510P1N42
62.1 (28.17)	1.500	1.000	0.187	0.076	CMP181510P2N35
64.8 (29.39)	1.500	1.000	0.187	0.076	CMP181510P2N42
86.4 (39.19)	1.500	1.500	0.125	0.076	CMP011515P1N42
<b>Adhesive-Back Rare Earth Max-Attach™</b>					
<b>Disc with 3M VHB (Very High Bond) Adhesive</b>					
16.5 (7.48)	1.000	-	0.062	0.014	CMP10006P1ADH
37.3 (16.92)	1.000	-	0.125	0.028	CMP10012P1ADH
38.4 (17.42)	1.000	-	0.187	0.041	CMP10018P2ADH
77.0 (34.93)	1.500	-	0.125	0.061	CMP15012P1ADH
<b>Ring with 3M VHB (Very High Bond) Adhesive</b>					
33.2 (15.06)	1.000	0.125	0.125	0.027	CMP101912P2ADH
67.3 (30.53)	1.500	0.125	0.125	0.060	CMP151212P2ADH
<b>Rectangle with 3M VHB (Very High Bond) Adhesive</b>					
13.1 (5.94)	0.500	0.500	0.125	0.009	CMP010505P1ADH
17.1 (7.76)	1.000	0.500	0.125	0.018	CMP010510P1ADH
26 (11.79)	1.000	1.000	0.060	0.018	CMP061010P2ADH
39.8 (18.05)	1.000	1.000	0.125	0.035	CMP011010P1ADH
64.8 (29.39)	1.500	1.000	0.187	0.078	CMP181510P2ADH
86.4 (39.19)	1.500	1.500	0.125	0.078	CMP011515P1ADH

Max-Attach™ are Rare Earth Neodymium-Iron-Boron multi-pole magnets that produce superior attachment force. They are many times stronger than conventional N and S pole magnets.

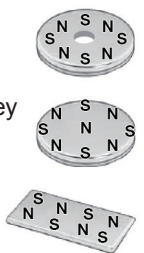

### Adhesive-Back Max-Attach™ Ultra-High-Pull Neodymium Magnets

The adhesive back lets you press these corrosion-resistant, nickel-plated neodymium-iron-boron Rare Earth magnets into place on non-ferrous surfaces. Multi-pole magnets achieve substantially more holding power versus conventionally magnetized magnets. Maximum temperature is 180°F (82°C). Color is silver. They cannot be machined.



# CYLINDRICAL FIXTURE MAGNET ASSEMBLIES

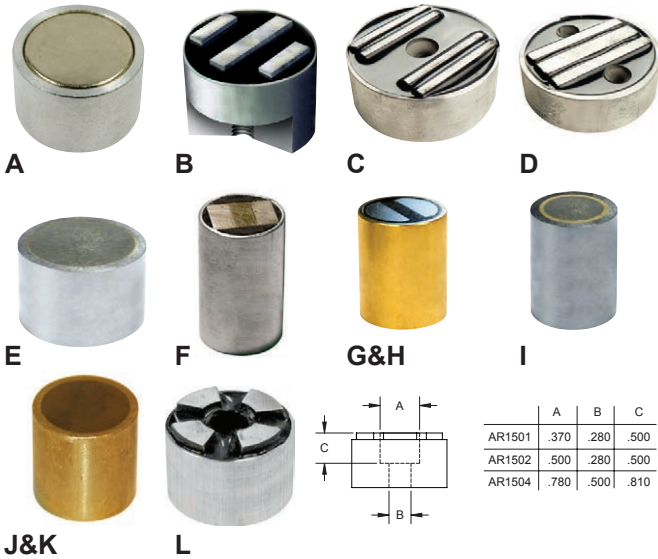

	Hold - lbs (kg)	Dia. (in)	Ln. (in)	Tap Size	Depth	Wt. (lbs)	Model No.
A1	0.25 (0.11)	1/4	1/2	#6-32	1/4	0.01	N250T
A1	1.30 (0.59)	3/8	1/2	#8-32	1/4	0.01	N375T
A1	2.65 (1.20)	1/2	1/2	#10-24	1/4	0.01	N500T
A1	4.35 (1.97)	5/8	1/2	#10-24	1/4	0.02	N625T
A1	6.00 (2.72)	3/4	1/2	#10-24	1/4	0.03	N750T
A1	7.50 (3.40)	1	1/2	#1/4-20	1/4	0.06	N1000T
A2	7.80 (3.54)	3/4	1/2	#10-24	1/4	0.03	CMP750T
A2	10.4 (4.72)	1	1/2	#1/4-20	1/4	0.06	CMP1000T
B	15.50 (7.03)	1	3/4	#1/4-20	1/4	0.08	N3T1002
B	26.00 (11.79)	1-1/4	3/4	#5/16-18	1/4	0.14	N3T1252
C	45.00 (20.41)	2	1/2	#1/4 - Flat	-	0.18	C4H2000
C	50.00 (22.68)	2	3/4	#1/4 - Flat	-	0.26	C4H2002
C	60.00 (27.21)	2	1	#1/4 - Flat	-	0.33	C4H2004
C	90.00 (40.82)	2-1/2	1	#1/4 - Flat	-	0.53	C4H2504
D	145.00 (65.77)	3	1	#1/4 - Flat	-	1.23	C5H3004
E	3.00 (1.36)	3/8	1/2	#8-32	.100	0.02	R375
E	8.00 (3.63)	1/2	1/2	#10-32	.120	0.03	R500
E	22.00 (9.98)	3/4	1/2	#10-32	.150	0.06	R750
E	46.00 (20.86)	1	1/2	#1/4-20	.150	0.10	R1000
E	50.00 (22.68)	1-1/4	1/2	#5/16-18	.150	0.16	R1250
F	6.00 (2.72)	1/2	1/2	-	-	0.05	N500
F	18.00 (8.16)	3/4	1-3/16	#1/4-20	1/4	0.10	NT750
F	43.00 (19.50)	1	1-5/16	#1/4-20	5/16	0.20	NT1000
F	102.00 (46.26)	1-1/2	2-1/16	#5/16-18	5/16	0.60	NT1500
F	172.00 (78.01)	2	2-7/16	#3/8-16	5/16	1.30	NT2000
G	0.90 (0.41)	06 mm	20 mm	-	-	0.02	PF06N
G	4.40 (1.99)	10 mm	20 mm	-	-	0.03	PF10N
G	6.60 (2.99)	13 mm	20 mm	-	-	0.04	PF13N
G	13.80 (6.26)	16 mm	20 mm	-	-	0.06	PF16N
G	25.40 (11.52)	20 mm	25 mm	-	-	0.14	PF20N
H	0.90 (0.41)	06 mm	20 mm	-	-	0.02	PF06S
H	4.40 (1.99)	10 mm	20 mm	-	-	0.03	PF10S
H	6.60 (2.99)	13 mm	20 mm	-	-	0.04	PF13S
H	13.80 (6.26)	16 mm	20 mm	-	-	0.06	PF16S
H	25.40 (11.52)	20 mm	25 mm	-	-	0.14	PF20S
H	44.10 (20.00)	25 mm	35 mm	-	-	0.30	PF25S
I	0.13 (0.05)	1/4	1/2	#8-32	3/32	0.01	A250
I	0.72 (0.32)	3/8	1/2	#8-32	3/32	0.02	A375
I	1.13 (0.51)	1/2	1/2	#10-32	5/32	0.03	A500
I	1.54 (0.70)	1/2	3/4	#10-32	3/16	0.04	A502
I	1.19 (0.54)	5/8	1/2	#10-32	5/32	0.07	A625
I	2.69 (1.22)	3/4	1/2	#10-32	5/32	0.06	A750
I	4.56 (2.07)	3/4	3/4	#10-32	1/4	0.06	A752
I	4.69 (2.13)	3/4	1	#10-32	1/4	0.08	A754
I	4.00 (1.81)	1	1/2	#1/4-20	5/32	0.11	A1000
I	7.25 (3.29)	1	1	#1/4-20	9/32	0.21	A1004
I	12.50 (5.67)	1-1/4	1-1/4	#1/4-20	9/32	0.39	A1256
<b>Wall Th.</b>							
J	0.025 (0.0113)	3/16	1/4	0.018	-	0.01	ABS1825
J	0.040 (0.0181)	3/16	1/2	0.018	-	0.01	ABS1850
J	0.055 (0.0249)	1/4	1/4	0.032	-	0.01	ABS2525
J	0.140 (0.0635)	1/4	1/2	0.032	-	0.01	ABS2550
J	0.060 (0.0272)	5/16	1/4	0.032	-	0.01	ABS3125
J	0.175 (0.0793)	5/16	1/2	0.032	-	0.01	ABS3150
J	0.100 (0.0453)	3/8	3/8	0.032	-	0.01	ABS3737
J	0.200 (0.0907)	3/8	3/4	0.032	-	0.01	ABS3775
J	0.225 (0.1021)	1/2	1/2	0.032	-	0.03	ABS5050
J	0.680 (0.3084)	3/4	3/4	0.062	-	0.06	ABS7575
K	0.13 (0.059)	1/8	1/4	0.018	-	0.01	RBS1225
K	0.37 (0.168)	3/16	1/4	0.032	-	0.01	RBS1825
K	0.88 (0.399)	1/4	1/4	0.032	-	0.01	RBS2525
K	0.95 (0.043)	1/4	1/2	0.032	-	0.01	RBS2550
K	1.00 (0.45)	5/16	1/4	0.032	-	0.01	RBS3125
K	2.63 (1.19)	3/8	3/8	0.032	-	0.01	RBS3737
K	3.13 (1.42)	1/2	1/4	0.062	-	0.03	RBS5025
K	4.63 (2.10)	1/2	1/2	0.062	-	0.03	RBS5050
K	7.50 (3.40)	3/4	3/8	0.062	-	0.05	RBS7537
<b>Socket Poles</b>							
L	8.00 (3.63)	1-1/8	25/32	#1/4-20	4	0.10	AR1501
L	12.00 (5.44)	1-3/8	25/32	#1/4-20	6	0.30	AR1502
L	35.00 (15.88)	2-1/2	1-9/32	#1/2-13	8	1.30	AR1504

## Cylindrical Fixture Assemblies

**A1:** Rare Earth Neodymium 1-Pole magnet in an Aluminum insulated cup. Powerful compact magnet that can be press fit or use tapped hole for mounting. +/- .003" diameter & .015" length. Maximum temperature 180°F (82°C).

**A2:** Max-Attach™ Rare Earth Neodymium in an Aluminum insulated cup. Multi-pole compact magnet that can be press fit or use tapped hole for mounting. +/- .003" diameter & .015" length. Maximum temperature 180°F (82°C).

**B:** Rare Earth 3-Pole magnet in an Aluminum insulated cup. Extended poles can be lightly machined. Can be press fit or use tapped hole for mounting. +/- .003" diameter & .015" length. Maximum temperature 180°F (82°C).

**C:** Rare Earth Neodymium 4-Pole magnet in an Aluminum insulated cup. Extended poles can be lightly machined. Can be press fit or use thru-hole for mounting. +/- .008" diameter & +/- .015" length. Maximum temperature 180°F (82°C).

**D:** Rare Earth Neodymium 3-Pole magnet in an Aluminum insulated cup. Maximum strength in a compact package. Can be press fit or use thru-holes for mounting. +/- .008" dia. & +/- .015" length. Maximum temperature 180°F (82°C). Mounting hole center 1-13/16".

**E:** Rare Earth Neodymium Island 2-Pole magnet in a steel cup. Ideal for shallow fixtures. Can not be press fit without additional insulation. Use tapped hole for mounting. +/- .005" dia. & +/- .015" length. Maximum temperature 180°F (82°C).

**F:** Rare Earth Neodymium parallel 2-Pole magnet in an Aluminum insulated cup. Flush face magnet, can be press fit or use tapped hole for mounting. +/- .008" diameter & +/- .015" length. Maximum temperature 180°F (82°C).

**G:** Rare Earth Neodymium parallel 2-Pole magnet in a brass insulated cup. Ideal for metric press fit applications. +/- .002" diameter & length. Maximum temperature 180°F (82°C).

**H:** Rare Earth Samarium Cobalt parallel 2-Pole magnet in a brass insulated cup. Ideal for high heat metric press fit applications. +/- .002 diameter & length. Maximum temperature 392°F (200°C).

**I:** Alnico Island 2-Pole magnet in a steel cup. Especially effective in mold applications. Can not be press fit without additional insulation. Use tapped hole for mounting. +/- .005" diameter & +/- .015" length. Maximum temperature 800°F (427°C).

**J:** Alnico magnet material shielded in a non-conductive sleeve, 1-Pole on each end. Insulator prevents loss of magnetic flux when inserted into steel components or fixtures. No mounting holes. +/- .001" diameter & +/- .005" length. Maximum temperature 800°F (427°C).

**K:** Rare Earth Neodymium magnet material shielded in a non-conductive sleeve, 1-Pole on each end. Insulator prevents loss of magnetic flux when inserted into steel components or fixtures. No mounting holes. +/- .001 diameter & +/- .005" length. Maximum temperature 180°F (82°C).

**L:** Alnico Multi-Pole magnet in an Aluminum insulated cup. Very effective on thin metal or difficult applications. Counter sunk mounting hole for easy installation. +/- .006" diameter & +/- .015" length. Maximum temperature 300°F (148°C).

# CUP MAGNET ASSEMBLIES



## Plated Cup Magnet Assemblies

Secure tarps, cables, wires, brooms and more to any steel surface, including overhead beams, ceiling decks, drop ceiling channels and metal joists. These cup magnet assemblies are quickly installed and repositioned. Plated, low profile, cup magnet assemblies are ideal for holding, hanging, mounting and more.

Note: Ceramic cup magnets are heat resistant up to 300°F (148°C). Rare Earth cup magnets are heat resistant up to 180°F (82°C). Cup magnet (base) +/-0.005" on all dimensions.

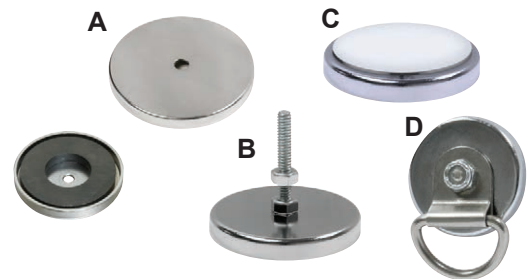

Style	Max - lbs (kg)	Description	Magnet	O.D. (in)	Through Hole (in)	Magnet I.D. (in)	OAH (in)	Wt. (lbs)	Model No.
A	23.0 (10.43)	Low Profile Cup	Rare Earth	0.79	0.177	0.32	0.275	0.04	MX0787R
A	36.0 (16.33)	Low Profile Cup	Rare Earth	0.98	0.216	0.35	0.315	0.05	MX0984R
A	15.0 (6.80)	Low Profile Cup	Ceramic	1.24	0.156	0.25	0.188	0.03	MX1000
A	38.0 (17.24)	Low Profile Cup	Rare Earth	1.24	0.125	0.25	0.188	0.03	MX1000R
A	25.0 (11.34)	Low Profile Cup	Ceramic	1.41	0.188	0.375	0.281	0.05	MX1500
A	51.0 (23.13)	Low Profile Cup	Rare Earth	1.41	0.188	0.375	0.281	0.05	MX1500R
A	42.0 (19.05)	Low Profile Cup	Ceramic	2.03	0.188	0.859	0.313	0.15	MX2000
A	83.0 (37.65)	Low Profile Cup	Rare Earth	2.03	0.188	0.438	0.313	0.10	MX2002R
A	110.0 (49.90)	Low Profile Cup	Rare Earth	2.03	0.188	0.438	0.313	0.12	MX2004R
A	80.0 (36.29)	Low Profile Cup	Ceramic	2.63	0.281	1.00	0.375	0.30	MX2500
A	200.0 (90.72)	Low Profile Cup	Rare Earth	2.63	0.281	0.625	0.375	0.40	MX2508R
A	112.0 (50.80)	Low Profile Cup	Ceramic	2.88	0.281	1.00	0.375	0.35	MX2750
A	140.0 (63.5)	Low Profile Cup	Ceramic	3.18	0.281	1.203	0.438	0.53	MX3000
A	147 (66.68)	Low Profile Cup	Ceramic	3.87	0.38	1.28	0.510	0.95	MX3870
A	170.0 (77.11)	Low Profile Cup	Ceramic	4.90	0.500	1.75	0.5	1.50	MX5000
A	270.0 (122.47)	Low Profile Cup	Rare Earth	4.90	0.500	1.75	0.5	1.50	MX5000R
<b>Thread</b>									
B	15.0 (6.80)	Cup w/ Bolt & Nuts	Ceramic	1.24	6-32	0.25	1.188	0.05	MX1000B
B	25.0 (11.34)	Cup w/ Bolt & Nuts	Ceramic	1.41	8-32	0.375	1.375	0.10	MX1500B
B	42.0 (19.05)	Cup w/ Bolt & Nuts	Ceramic	2.03	10-24	0.859	1.063	0.20	MX2000B
B	83.0 (37.65)	Cup w/ Bolt & Nuts	Rare Earth	2.03	10-24	0.438	1.566	0.20	MX2002RB
B	110.0 (49.90)	Cup w/ Bolt & Nuts	Rare Earth	2.03	10-24	0.438	1.566	0.22	MX2004RB
B	5.0 (2.27)	Cup w/ Bolt & Nuts	Ceramic	2.25	5/16-18	-	1.188	0.33	MX2250B
B	80.0 (36.29)	Cup w/ Bolt & Nuts	Ceramic	2.63	1/4-20	1.00	2.120	0.40	MX2500B
B	200.0 (90.72)	Cup w/ Bolt & Nuts	Rare Earth	2.63	1/4-20	0.625	2.120	0.50	MX2508RB
B	112.0 (50.80)	Cup w/ Bolt & Nuts	Ceramic	2.88	1/4-20	1.00	2.120	0.45	MX2750B
B	140.0 (63.5)	Cup w/ Bolt & Nuts	Ceramic	3.18	1/4-20	1.203	2.180	0.60	MX3000B
B	170.0 (77.11)	Cup w/ Bolt & Nuts	Ceramic	4.90	3/8-16	1.75	2.120	1.70	MX5000B
C	7.0 (3.18)	Low Profile Cup w/ Adhesive Back	Ceramic	1.24	0.156	0.25	0.188	0.03	MX1000ADH
C	11.0 (4.99)	Low Profile Cup w/ Adhesive Back	Ceramic	1.41	0.188	0.375	0.281	0.05	MX1500ADH
C	19.0 (8.62)	Low Profile Cup w/ Adhesive Back	Ceramic	2.03	0.188	0.859	0.313	0.10	MX2000ADH
<b>Opening (in)</b>									
D	15.0 (6.80)	"D" Loop	Ceramic	1.24	0.43 x 0.75	0.25	0.375	0.05	MX1000DL
D	25.0 (11.34)	"D" Loop	Ceramic	1.41	0.43 x 0.75	0.375	0.50	0.10	MX1500DL
D	42.0 (19.05)	"D" Loop	Ceramic	2.03	0.43 x 0.75	0.859	0.5625	0.15	MX2000DL

## Rubber Protection Boots For Cup Base Magnets

Ideal for protecting painted, plated, polished, etc. surfaces from scratches. Boots also increase resistance to shear forces. Rubber boots fit over the magnetic face of cup magnets. Note: Using a rubber boot on a cup magnet will reduce the magnet's holding power due to air gap. See holding power below.

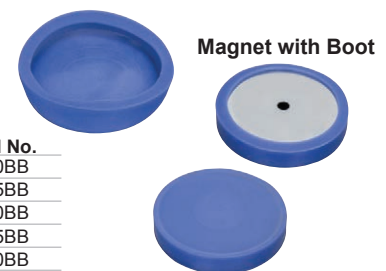

Color	Air Gap (in)	Wt. (lbs)	Fits: MAX lbs (kg)	Model No.
Blue	0.032	0.001	MX1000: 2.3 (1.04); MX1000R: 11 (4.99)	MX10BB
Black	0.045	0.001	MX1500: 3.4 (1.54); MX1500R: 13.3 (6.03)	MX15BB
Blue	0.022	0.001	MX2000: 9.5 (4.31); MX2002R: 31.4 (14.24); MX2004R: 47.2 (21.41)	MX20BB
Black	0.042	0.020	MX2500: 18.3 (8.30); MX2508R: 70.0 (31.75)	MX25BB
Black	0.035	0.030	MX3000: 37.9 (17.91)	MX30BB
Blue	0.045	0.050	MX5000: 70.0 (31.75); MX5000R: 117.5 (53.30)	MX50BB

## Magnetic Wire Cable Holders

Secure cables and wires with these powerful magnets. Fast installation without drilling holes. Remove or reposition magnets when needed. Part number MX0560RZIP6 contains 6 one-piece galvanized steel zip tie.



Style	Max - lbs (kg)	Description	Magnet	O.D. (in)	Through Hole (in)	Magnet I.D. (in)	OAH (in)	Wt. (lbs)	Model No.
A	7.0 (3.17)	Black Plastic Zip Tie Holder	Ceramic	1.24	0.16 x 0.38	0.25	0.44	0.05	MX1000ZIP1
A	35.0 (15.87)	Black Plastic Zip Tie Holder	Rare Earth	1.24	0.16 x 0.38	0.25	0.44	0.05	MX1000RZIP1
B	7.0 (3.17)	Black Plastic Holder & Reusable Zip Tie	Ceramic	1.24	0.16 x 0.38	0.25	0.44	0.05	MX1000ZIP2
B	35.0 (15.87)	Black Plastic Holder & Reusable Zip Tie	Rare Earth	1.24	0.16 x 0.38	0.25	0.44	0.05	MX1000RZIP2
C	7.0 (3.17)	Black Plastic Cable Holder	Ceramic	1.24	0.44 - 1.00	0.25	0.75	0.05	MX1000CBL1
D	6.0 (2.72)	Galvanized Steel	Rare Earth	0.56	0.21 x 0.10	0.56	0.06	0.05	MX0560RZIP6

# TUBE CLAMPS & DOOR STOPS/LATCHES



## Magnetic Tube Clamps

Powerful permanent magnetic clamp securely holds water lines, cables, electrical conduit, etc. to steel walls, beams or structures. They eliminate the need to drill mounting holes, making installation or future repositioning fast and easy!

### Features

- No holes to drill
- Closes and locks automatically when pipe, tube or cable is inserted
- Reusable one-piece clamps



MX1000T075

Hold - lbs (kg)	Magnet	Clamp Size (in)	Width (in)	Magnet Dia. (in)	OAH (in)	Wt. (lbs)	Model No.
7.0 (3.18)	Ceramic	3/8	-	1.24	1.37	0.05	MX1000T037
7.0 (3.18)	Ceramic	1/2	-	1.24	1.50	0.05	MX1000T050
11.0 (4.99)	Ceramic	3/4	-	1.41	2.00	0.10	MX1500T075
42.5 (19.28)	Rare Earth	3/4	-	1.41	2.00	0.10	MX1500RT075
19.0 (8.62)	Ceramic	1	-	2.03	2.25	0.20	MX2000T100
47.5 (21.55)	Rare Earth	1	-	2.03	2.25	0.20	MX2002RT100
<b>OVL (in)</b>							
43.5 (19.73)	Rare Earth	3/4	1.37	3.50	2.12	0.21	LP2100R2T075
43.5 (19.73)	Rare Earth	1	1.37	3.62	2.37	0.22	LP2100R2T100

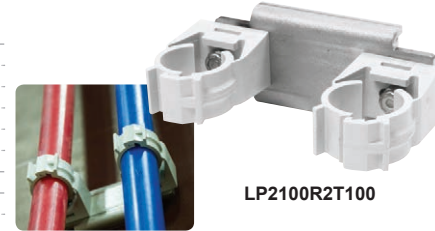

LP2100R2T100

## Magnetic Door Latches

These extremely powerful Rare Earth magnetic latches have a very thin profile. Ideal for door & cabinet applications or for mounting panels, signs, pictures, etc. Plated magnet, washers and screws reduce corrosion. Washers are recessed to allow the screw head to set below the contact area.

### Features

- ML050 uses 3M VHB Adhesive on the magnet
- Screw(s) included are #6 x 5/8" long



Hold - lbs (kg)	OD (in.)	Magnet		Strike Plate		Wt. - lbs	Model No.
		TH (in.)	Hole Dia. (in.)	OD (in.)	TH (in.)		
2 (0.91)	0.50	0.06	N/A	0.56	.070	.221	0.0001 ML050
13 (5.90)	0.75	0.12	0.18	0.70	.070	.221	0.01 ML075
37 (16.78)	0.98	0.31	0.21	1.00	.070	.221	0.05 ML098

## Magnetic Door Holders/Stops



### Features

- Powerful Rare Earth magnetic connection systems can be used to hold doors & cabinets in the open position or to attach key rings, knives & tools in both indoor and outdoor applications.
- Ideal for workshops, home, office, garage, RV or marine settings.
- Magnets are embedded inside a non-marring housing and come with several different mounting options, including adhesive, screws or rivets.

### Magnetic Connectors

- ABS plastic housing
- 3M adhesive backing

### Trailer/Wall Mount Models

- Non-marring EPDM\* rubber housing
- Mounting screws included

### Floor Mount Models

- Non-marring EPDM\* rubber housing
- Powder coated steel floor bracket
- Mounting screws included



Max Hold - lbs (kg)	Description	Flange Dia. (in)	Magnet Dia. (in)	Projects (ea) (in)	Wt. (lbs)	Magnet Color	Model No.
<b>Magnetic Connector Models (Black or White)</b>							
5.5	2 Magnets	1-1/2	3/4	9/16	0.05	Black	D1BL
5.5	2 Magnets	1-1/2	3/4	9/16	0.05	White	D1WH

Max Hold - lbs (kg)	Description	Flange Dia. (in)	Magnet Dia. (in)	Projects (in)	Wt. (lbs)	Magnet Color	Model No.
<b>Floor Mount Model</b>							
27	1 Magnet, 1 Plate, 1 Bracket, Hardware	3-1/2	1-3/8	2-3/4	2.20	Orange	D3X1BKT
31	2 Magnets, 1 Plate, 1 Bracket, Hardware	3-1/2	1-3/8	2-3/4	2.45	Orange/Black	D3X2BKT

Note: Models with 2 magnets project farther than most door knobs

Max Hold - lbs (kg)	Description	Flange Dia. (in)	Magnet Dia. (in)	Projects (in)	Wt. (lbs)	Magnet Color	Model No.
<b>Trailer Mount Model</b>							
27	1 Magnet, 1 Hardware	3-1/2	1-3/8	1-3/8	0.45	Black	D3X1BL
27	1 Magnet, 1 Plate, Hardware	3-1/2	1-3/8	1-3/8	0.65	Black	D3X1BLP
31	2 Magnets, Hardware	3-1/2	1-3/8	2-3/4	0.90	Black	D3X2BL

Note: Models with 2 magnets project farther than most door knobs

\*EPDM = Ethylene Propylene Diene Monomer (Type of Synthetic Rubber)

# RECTANGULAR FIXTURE MAGNET ASSEMBLIES **MAG-MATE®**

## Rectangular Fixture Assemblies

	Hold - lbs (kg)	Th. (in)	Wd. (in)	Ln. (in)	No. of Poles	Wt. (lbs)	Model No.
A	22.5 (10.21)	1-1/4	1	4-1/2	2	0.64	AC2100
A	27.5 (12.48)	1-1/4	1	4-1/2	2	0.65	AC2101
A	32.5 (14.75)	1-1/4	1	4-1/2	2	0.66	AC2102
A	39.0 (17.69)	1-1/4	1-1/4	4-1/2	2	0.84	AC2103
A	59.0 (26.76)	1-1/4	1-1/4	4-1/2	3	0.88	AC2201
A	65.0 (29.49)	1-1/4	1-7/8	4-1/2	3	1.19	AC2203
A	79.0 (35.83)	1-1/4	1-7/8	4-1/2	3	1.28	AC2204
A	115.5 (52.39)	1-1/4	2-1/2	4-1/2	4	1.75	AC2303
B	80.0 (36.29)	1-1/4	1	4-1/2	2	0.66	AC2102R
B	95.0 (43.10)	1-1/4	1-1/4	4-1/2	2	0.84	AC2103R
B	178.0 (80.74)	1-1/4	1-7/8	4-1/2	3	1.28	AC2204R
	Ctrs (in)						
C	12.5 (5.67)	3/8	1-3/8	3-1/4	2-5/8	0.10	LP2100
C	43.5 (19.73)	3/8	1-3/8	3-1/4	2-5/8	0.20	LP2100R
C	13.5 (6.12)	7/16	1-3/8	3-1/4	2-5/8	0.30	LP2101
C	14.5 (6.58)	7/16	1-3/8	3-1/4	2-5/8	0.30	LP2102
C	15.5 (7.03)	9/16	1-3/8	3-1/4	2-5/8	0.30	LP2103
D	17.5 (7.94)	1	1-5/8	2	1-1/2	0.20	5C2565
E	10.0 (4.54)	5/8	1-1/8	3-5/8	2-7/8	0.10	SS2103
E	15.0 (6.81)	5/8	1-5/8	3-5/8	2-7/8	0.30	SS2100
F	31.0 (14.06)	9/16	2-3/8	2-3/4	1-1/4	0.50	WH2100
G	32.0 (14.52)	5/8	1/2	3	2-1/2	0.10	MX10354
H	40.0 (18.14)	1-3/8	7/8	3-1/4	2-3/4	0.55	BP0040
H	60.0 (27.21)	1-3/8	1-1/4	3-1/4	2-3/4	0.70	BP0060
H	120.0 (54.43)	1-3/8	1-1/4	5-1/4	4-1/2	1.35	BP0120
H	250.0 (113.39)	2-1/4	1-7/8	5-1/4	4-1/2	3.25	BP0250
I	14.0 (6.35)	3/16	9/16	1-3/4	1.47	0.10	MX0477
J	9.0 (4.09)	9/16	1	2-1/2	2	0.20	LC2360
J	21.0 (9.53)	9/16	1	4-1/2	4	0.40	LC2361
J	29.0 (13.16)	9/16	1	6-1/2	6	0.60	LC2362
J	60.0 (27.22)	9/16	1	12-1/2	12	1.30	LC2363
J	88.0 (39.92)	9/16	1	18-1/2	18	1.80	LC2364
J	25.0 (11.34)	11/32	1-1/2	12	11	1.12	MQ1129
J	63.0 (28.58)	5/8	1-1/2	12	11	1.62	MQ1130
J	150.0 (68.04)	5/8	2-1/2	12	11	2.74	MQ1132

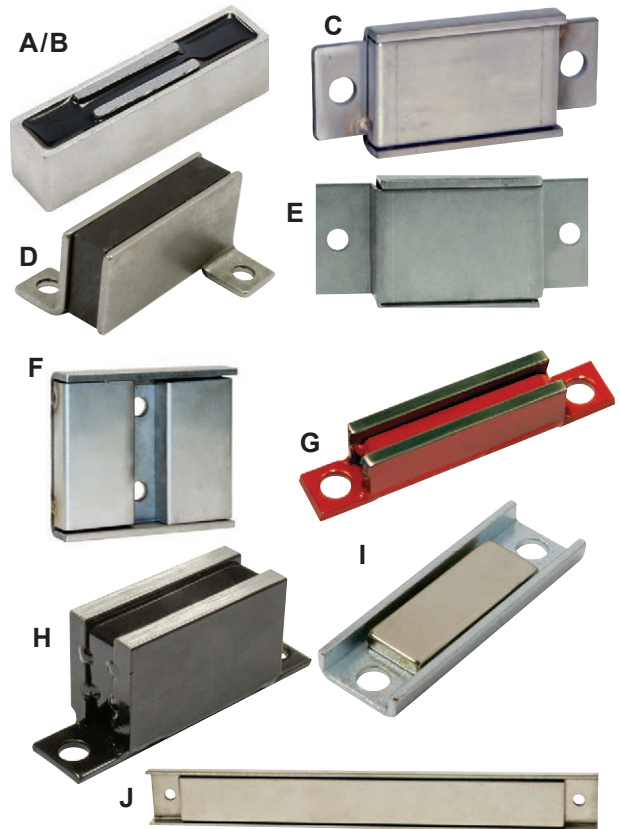

- A:** Ceramic magnet, 2, 3 or 4-Pole assembly potted in an aluminum housing. Effective for holding heavy parts & holding against shear forces. Supplied without mounting holes, they can be drilled, tapped, milled, etc. on either end of the magnet. Maximum temperature 300°F (148°C). USA M.A.D.E.™
- B:** Rare Earth magnet material, 2 or 3-Pole assembly potted in an aluminum housing. Effective for holding heavy parts & holding against shear forces. Supplied without mounting holes, they can be drilled, tapped, milled, etc. on either end of the magnet. Maximum temperature is 180°F (82°C). USA M.A.D.E.™
- C:** Ceramic magnet (except LP2100R is Rare Earth) placed in a 400 Stainless Steel channel covered with 300 stainless steel. Use 1/4"-20 (m6) bolt or screws for mounting this non-corrosive 2-pole assembly. Maximum temperature 300°F (148°C). Rare Earth maximum temperature is 180°F (82°C). USA M.A.D.E.™
- D:** Ceramic magnet sandwiched between steel pole pieces. Use 10-24 (m5) bolt or screws for mounting this non-corrosive 2-Pole assembly. Maximum temperature 300°F (148°C).
- E:** Paint Rack magnet uses a 400 Stainless Steel channel covered with 300 stainless steel. Use 1/4"-20 (m6) bolt or screws for mounting this non-corrosive 2-Pole assembly. Maximum temperature 350°F (177°C). USA M.A.D.E.™
- F:** Two ceramic magnets placed in a 400 Stainless Steel channel covered with 300 Stainless Steel. Center mount using two 1/4" -20 (m6) bolt or screws for mounting this non-corrosive, 2-pole assembly. Maximum temperature 300°F (148°C).
- G:** Rare Earth magnet material is sandwiched between steel pole pieces and welded to a stainless steel back plate. This extremely powerful assembly is painted red and fits narrow openings. Use 1/4"-20 (m6) bolt or screws for mounting this 2-Pole assembly. Maximum temperature is 180°F (82°C). USA M.A.D.E.™
- H:** Ceramic magnet material is sandwiched between steel pole pieces. All-welded construction with a stainless steel cover. No Epoxy, painted black. Can be used for holding and transferring of parts, or for aligning pieces during welding operations and as the holding elements on paint racks. Use 1/4"-20 (m6) bolt or screws for mounting this 2-Pole assembly. Maximum temperature is 480°F (248°C). USA M.A.D.E.™
- I:** Nickel Plated Rare Earth magnet material is glued to a bright plated steel channel. This extremely powerful assembly is ideal for low profile applications that require strong pull pounds. Use 10-32 (m5) bolt or screws for mounting this 2-Pole assembly. Maximum temperature is 180°F (82°C).
- J:** Ceramic magnet material placed in a 400 Stainless Steel channel and covered. This full-length magnetic holding force gives generous room for various fastener heads. Use 10-24 (m5) bolt or screws for mounting this non-corrosive 2-Pole assembly. Maximum temperature 300°F (148°C). Prefix LC = USA M.A.D.E.™

# MAGNETIC JIGS, STRIPS & SHEETS



## ON/OFF Rare Earth Jig Magnets

### Features

- Easy On/Off controls for fast, strong, and precise positioning
- Use at least two per fixture; add more for even greater holding force.
- Jigs flange 0.50" thick secured with two #8 screws and will mount flush on 3/4" board – Use 40mm Forstner bit for large Jigs & 30mm for small Jigs.

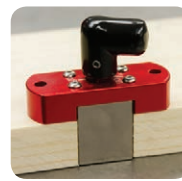

Non-Flange

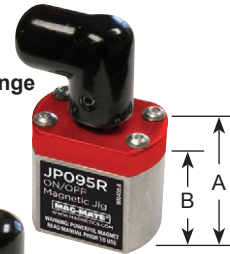

Flanged

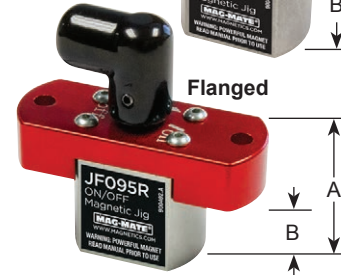

Hold - lbs (kg)	Description	Magnet Dia.		Overall Dimensions			A	B	Wt. (lbs)	Model No.
		(in)	(mm)	Ht (in)	Wd. (in)	Ln. (in)	Ht (in)	Depth (in)		
95.0 (43.09)	Non-Flange	1.18	30	2.18	0.85	1.18	1.25	1.00	0.30	JP095R
155.0 (70.30)	Non-Flange	1.57	40	2.18	1.25	1.57	1.25	1.00	0.55	JP155R
95.0 (43.09)	Flanged	1.18	30	2.18	0.85	2.25	1.25	0.75	0.35	JF095R
155.0 (70.30)	Flanged	1.57	40	2.18	1.25	2.64	1.25	0.75	0.60	JF155R

## Flexible Magnetic Strips

### Features

- Conforms to any contour
- Can be cut, drilled or shaped
- Available in plain or adhesive back

In general, the following tolerances apply to all Magnetic Strips: Thickness:  $\pm 0.005''$ , Widths: 0" to 2" =  $\pm 0.015''$  or 2" to 3" =  $\pm 0.030''$ , Lengths:  $\pm 1\%$  or  $\pm 0.015''$  whichever is greater. Temperature Range: operating temperatures  $-15^{\circ}\text{F}$  to  $160^{\circ}\text{F}$  ( $-26^{\circ}\text{C}$  to  $71^{\circ}\text{C}$ ).



Max Hold - lbs (kg) / In. ft.	Th. (in)	Wd. (in)	Ln. (ft)	Wt. (lbs)	Model No. Plain Back	Model No. Adhesive Back
2.0 (0.90)	1/32	1/2	25	0.58	MRN030X0050X025	MRA030X0050X025
2.0 (0.90)	1/32	1/2	50	1.15	MRN030X0050X050	MRA030X0050X050
2.0 (0.90)	1/32	1/2	100	2.3	MRN030X0050X100	MRA030X0050X100
2.0 (0.90)	1/32	1/2	200	4.6	MRN030X0050X200	MRA030X0050X200
3.0 (1.36)	1/32	3/4	50	1.7	MRN030X0075X050	MRA030X0075X050
3.0 (1.36)	1/32	3/4	100	3.4	MRN030X0075X100	MRA030X0075X100
3.0 (1.36)	1/32	3/4	200	6.8	MRN030X0075X200	MRA030X0075X200
4.0 (1.81)	1/32	1	25	1.15	MRN030X0100X025	MRA030X0100X025
4.0 (1.81)	1/32	1	50	2.3	MRN030X0100X050	MRA030X0100X050
4.0 (1.81)	1/32	1	100	4.6	MRN030X0100X100	MRA030X0100X100
4.0 (1.81)	1/32	1	200	9.2	MRN030X0100X200	MRA030X0100X200
12.0 (5.44)	1/32	3	25	3.75	MRN030X0300X025	N/A
12.0 (5.44)	1/32	3	50	7.5	MRN030X0300X050	N/A
12.0 (5.44)	1/32	3	100	15.0	MRN030X0300X100	N/A
12.0 (5.44)	1/32	3	200	30.0	MRN030X0300X200	N/A
3.0 (1.36)	1/16	1/2	25	1.1	MRN060X0050X025	MRA060X0050X025
3.0 (1.36)	1/16	1/2	50	2.2	MRN060X0050X050	MRA060X0050X050
3.0 (1.36)	1/16	1/2	100	4.4	MRN060X0050X100	MRA060X0050X100
5.0 (2.26)	1/16	3/4	25	1.65	MRN060X0075X025	MRA060X0075X025
5.0 (2.26)	1/16	3/4	50	3.3	MRN060X0075X050	MRA060X0075X050
5.0 (2.26)	1/16	3/4	100	6.6	MRN060X0075X100	MRA060X0075X100
6.0 (2.72)	1/16	1	25	2.2	MRN060X0100X025	MRA060X0100X025
6.0 (2.72)	1/16	1	50	4.4	MRN060X0100X050	MRA060X0100X050
6.0 (2.72)	1/16	1	100	8.8	MRN060X0100X100	MRA060X0100X100
18.0 (8.16)	1/16	3	100	30.0	MRN060X0300X100	MRA060X0300X100
4.0 (1.81)	1/8	1/2	50	5.0	MRN120X0050X050	MRA120X0050X050
4.0 (1.81)	1/8	1/2	100	10.0	MRN120X0050X100	MRA120X0050X100
6.0 (2.72)	1/8	3/4	50	7.0	MRN120X0075X050	MRA120X0075X050
6.0 (2.72)	1/8	3/4	100	14.0	MRN120X0075X100	MRA120X0075X100
8.0 (3.63)	1/8	1	50	9.5	MRN120X0100X050	MRA120X0100X050
8.0 (3.63)	1/8	1	100	19.0	MRN120X0100X100	MRA120X0100X100
24.0 (10.89)	1/8	3	50	38.0	MRN120X0300X050	MRA120X0300X050
24.0 (10.89)	1/8	3	100	56.0	MRN120X0300X100	MRA120X0300X100

## White Magnetic Sheeting

### Features

- Can be cut, drilled or shaped
- Conforms to any contour
- Can be written on
- 1/32" thick
- 24-3/8" width

Use in your office, manufacturing, air vent covers or inventory for labeling applications or advertising.

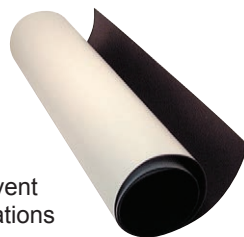

Max Hold - lbs (kg) / sq. ft.	Ln. (ft)	Wt. (lbs)	Model No.
85.0 (38.55)	1	1.15	MRS030X2437X001
85.0 (38.55)	10	13	MRS030X2437X010
85.0 (38.55)	25	31	MRS030X2437X025

## Magnetic Viewing Film

This film allows you to identify the magnetic field patterns of magnetic materials and assemblies. The viewing film can be used to check for damage to the magnet material within most types of magnet assemblies. Simply hold the film against the surface of any magnet and the pattern of the magnetic field is revealed. The 3" square sheets are reusable.

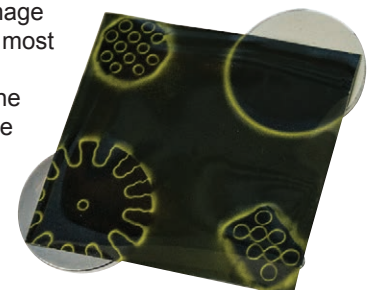

Part No. XX0044

# MAGNETS FOR HOLDING & SWEEPING



## Magnetic Print Holders

### Features

- Holds papers, prints, charts and more to steel desks, partitions, machinery, etc.
- Holds through many layers of prints



### Round Print Holders

Hold - lbs (kg)	Dia. (in)	Ht. (in)	OAH (in)	Wt. (lbs)	Model No.
7.0 (3.18)	1.24	0.19	0.69	0.08	PHMX1000*
11.0 (4.99)	1.41	0.28	1.03	0.10	PHMX1500*
19.0 (8.62)	2.03	0.31	1.06	0.18	PHMX2000*
41.0 (18.60)	2.63	0.38	1.13	0.38	PHMX2500*
47.5 (21.54)	3.18	0.44	1.19	0.61	PHMX3000*

\*Available in multi packs, ask your sales contact

### Rectangular Print Holders

Hold - lbs (kg)	Ht. (in)	Wd. (in)	Ln. (in)	Wt. (lbs)	Model No.
11.5 (5.22)	1.31	1.13	2.38	0.29	PH2100
19.0 (8.62)	1.29	1.63	2.00	0.34	PH2101
22.5 (10.21)	1.31	2.50	3.00	0.50	PH2102

## Nail & Screw Holder

Never hold nails in your mouth again. Handy magnetic wristband nail and screw holder provides a safe and convenient place to keep fasteners and small tools.

### Features

- 10" Band Circumference
- Prevents dropping of tools or fasteners



Type	Cup Dia. (in)	Cup Ht. (in)	OAH	Weight. (lbs)	Model No.
Wristband	2-1/32	5/16	0.390	0.24	MX2000W

## Magnetic Floor & Shop Sweepers



**SS:** Works on hard floors or carpeted areas. Clean shops, offices, retail stores right up to the edge of walls, machinery into corners with its unique wheel design.

**FS/IS:** Ideal for floors, parking lots and construction sites (IS is Self Cleaning).

**YS:** Aluminum and stainless steel construction for outdoor use. Hang the sweeper from vehicles, utility equipment or skid-steers.



Magnet Width (in)	Overall Width (in)	Depth (in)	Ht (in)	Wheel Dia (in)	Clearance (in)	Wt. (lbs)	Model No.
19	19-1/2	3	52	1-1/4	3/4	7.0	SS1800
12	16-1/2	5	48	6	1-3/4	11.0	FS1200
24	28-1/2	5	48	6	1-3/4	22.0	FS2400
36	40	5	48	6	1-3/4	31.0	FS3600
24	29-1/2	7-1/2	49-1/2	6	1-3/4	46.0	IS2400
24	24-1/2	5	2-11/16	-	-	35.0	YS2400
36	36-1/2	5	2-11/16	-	-	39.0	YS3600
48	48-1/2	5	2-11/16	-	-	52.0	YS4800
60	60-1/2	5	2-11/16	-	-	86.0	YS6000
84	84-1/2	5	2-11/16	-	-	91.0	YS8400

## Parts Retrievers

Remove Steel Parts from bins, boxes, kegs, tables or floors.

### Features

- Easy release of collected parts or scrap
- Powerful lightweight magnet
- Durable aluminum housing
- PR7800 stainless steel housing
- Comfortable non-slip handle



Handle	Max Lift - lbs (kg)	Ht. (in)	Wd. (in)	Ln. (in)	Wt. (lbs)	Model No.
Short	5.0 (2.27)	7-1/2	2-3/8	4-1/2	1.6	PR7100
Short	7.0 (3.18)	7-1/2	2-3/8	4-1/2	1.7	PR7200
Short	11.0 (4.99)	7-1/2	2-3/8	4-1/2	1.8	PR7400
Short	31.0 (14.06)	5-1/2	4-1/2	8-3/4	5.1	PR7800
Long	5.0 (2.27)	33-1/2	2-3/8	4-1/2	2.4	PR7100-30
Long	7.0 (3.18)	33-1/2	2-3/8	4-1/2	2.5	PR7200-30
Long	11.0 (4.99)	33-1/2	2-3/8	4-1/2	2.7	PR7400-30

## Spare Hand



Spring clamp with a flexible chrome plated steel shaft and a magnet base that can hold lights, books, prints, spray nozzles & more.

Magnet base doubles as a magnetic retriever.

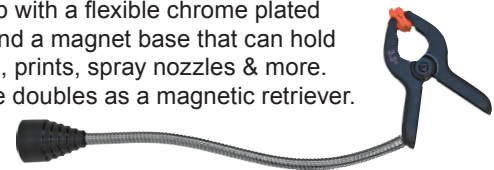

Max Opening (in)	Lift - lbs (kg)	Mag Head Dia. (in)	Ln. (in)	Wt. (in)	Model No.
1-1/4	20.0 (9.072)	1-1/8	13	0.45	990FLXCLP



# MAGNETS FOR CAPTURING METAL IN LIQUIDS



## Mag-Maid Coolant Clean Out Tool

This powerful Rare Earth clean-up tool safely removes metal chips and debris from machinery and work areas. The large comfortable handle is attached to Rare Earth magnets inside the seam-welded, stainless steel tube. To clean this tool, pull the handle away from the stainless steel tube. Collected scrap metal will follow the magnet up the tube until it hits the stripper washer. Once the magnet is past the stripper washer, the magnetic influence will dissipate and the metal falls off. No need to pull or wipe off collected metal. Available in 15" or 36" lengths. Maximum temperature 180°F (82°C).



Dia. (in)	Shaft Ln. (in)	Overall Ln. (in)	Wt. (lbs)	Model No.
1	15	19.25	1.25	MM1500EZ
1	36	40.25	2.75	MM3600EZ

## Salvage Magnets

### Features

- Retrieves tools, parts, key rings, fishing tackle & more
- Powerful ceramic magnets for wet or dry applications
- HDR3045 has a durable stainless steel case and can retrieve broken drill bits from oil & water wells



Lift - lbs (kg)	Size (in)	Wt. (lbs)	Model No.
35.0 (15.88)	3-1/2 Dia. x 2-1/2 L	1.07	DT3500
92.5 (41.96)	5-1/4 x 1-7/8 x 2-3/4	1.80	DT0600
300.0 (136.08)	3 Dia. x 5-3/4 L	5.00	HDR3045

## Clean-Out Retrievers



### Features

- Retrieve ferrous metal items from tanks, acid baths, oil reservoirs, heat bake ovens, etc.
- Alnico Magnet is attached to a 48 inch wood handle
- Max. temperature 300°F (148°C)



Lift - lbs (kg)	Dia. (in)	Ln. (in)	Wt. (lbs)	Model No.
12.0 (5.45)	1-3/8	48	1.60	COR12
35.0 (15.88)	2-1/2	48	2.50	COR35

## Magnetic Fluid Tank Cleaners



Our fluid tank cleaners are designed to capture minute ferrous particles in fluid tanks. This powerful Rare Earth permanent magnet helps to eliminate scored hydraulic cylinders, clogged orifices & "O" ring wear while increasing bearing, seal and pump life. These magnets are 1" diameter and sit on the bottom of the tank continuously cleaning fluids. Max. temp. 180°F (82°C).

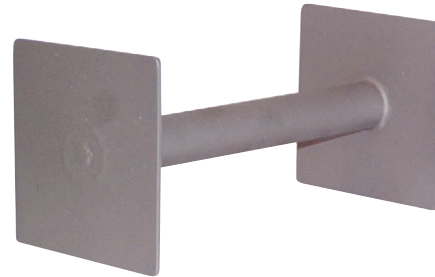

Ht. (in)	Wd. (in)	Ln. (in)	Clearance	Wt. (lbs)	Model No.
4	4	6	1-1/2	1.50	TC0600R
4	4	8	1-1/2	2.20	TC0800R

## Magnetic Coolant Filters

Magnetic coolant filters capture and remove ferrous metal chips and particles from water based coolants. Incorporate this magnetic filter in the coolant circulation system for continuous separation of metal contamination on processing machines such as:

### Features

- Precision grinding machine
- Cylindrical grinding machine
- Surface grinding machine
- Washing machine
- Honing machine
- Centerless grinding machine
- Rotary grinding machine
- Hardening machine

### Benefits

- Reduces coolant replacement costs
- Decreases equipment downtime
- Use before paper filters to extend filter life
- Outlet can be located on right, left or bottom



Order Online At [www.magnetics.com](http://www.magnetics.com) Or Email Us At [imi@magnetics.com](mailto:imi@magnetics.com)

# MAGNETIC RETRIEVERS & MECHANICAL FINGERS **MAG-MATE®**



## ■ Pocket Tools & Retrievers

Ideal for reaching behind, underneath or around machinery and/or difficult to reach areas. The Fixed Shaft and Telescoping Shaft Magnetic Retrievers feature several Magnet Head styles that include the Fixed Head, Single Ball Swivel Head and the Double Ball Swivel Hinge Head that allow for more control and functionality. Powerful Rare Earth magnet material, except where noted. All Rare Earth tools have a maximum temperature of 180°F (82°C).

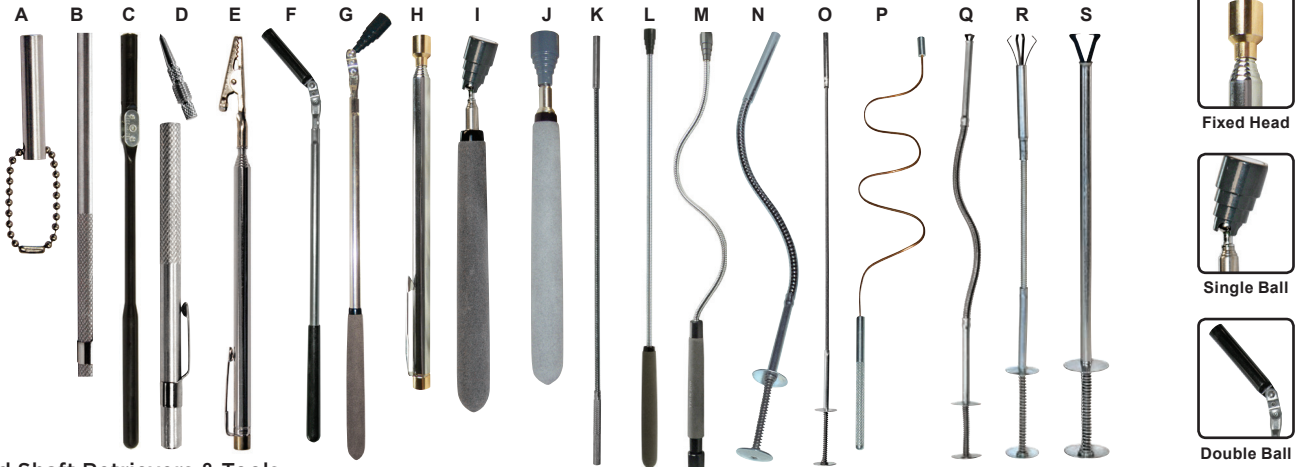

### Fixed Shaft Retrievers & Tools

Description	Lift - lbs (kg)	Shaft	Dia. (in)	Ln. (in)	Wt. (lbs)	Model No.
A Key chain retriever. Powerful Rare Earth magnet encased in an Aluminum Rod.	4.0 (1.815)	AL	3/8	2	0.03	KCR375
B Pen sized magnetic tool. Sturdy clip holds magnet firmly in pocket.	2.5 (1.134)	AL	5/16	6	0.06	906
C Double Ball Swivel Hinge Head. Non-conductive Nylon handle.	1.0 (0.453)	NY	5/16	8-1/4	0.05	909
D Precision ground carbide tip scribe is reversible. Magnet is located on the other end.	2.5 (1.134)	AL	5/16	5	0.05	92CLP

### Telescoping Shaft Retrievers & Tools

Description	Lift - lbs (kg)	Shaft	Dia. (in)	Ln. (in)	Ext. (in)	Wt. (lbs)	Model No.
E Stainless steel pen sized pilot lighter with match holding alligator clip.	N/A	SS	1/4	7-1/2	25-1/2	0.07	PL01
F Double Ball Swivel Hinge Head. Hex rod prevents magnet from swinging while in use.	7.5 (3.402)	ZP	1/2	17	26-1/2	0.36	927
G Double Ball Swivel Hinge Head. Hex rod prevents magnet from swinging while in use.	12.0 (5.444)	ZP	1/2	13	26	0.44	931
H Stainless steel pen sized tool for tiny jobs. Comes with pocket clip.	2.0 (0.908)	CP	5/16	5-1/2	25-1/2	0.07	240N
I Magnetic retriever w/ Single Ball Swivel Head and nonslip solvent-resistant comfort grip.	7.0 (3.176)	SS	5/8	8	35	0.19	925
J1	5.0 (2.268)	SS	3/8	6-1/2	32	0.14	923
J2 Magnetic retriever w/ fixed head and nonslip solvent-resistant comfort grip.	7.0 (3.176)	SS	5/8	6-1/2	32	0.18	924
J3	20.0 (9.072)	ZP	1-1/8	16-1/2	29	0.65	990SM
J4 Ex-long, heavy duty, magnetic retriever w/ fixed head & nonslip solvent-resistant comfort grip.	14.0 (6.351)	ZP/SS	5/8	23-1/2	50	0.42	926

### Flexible/Bendable Shaft Retrievers & Tools

Description	Lift - lbs (kg)	Shaft	Dia. (in)	Ln. (in)	Wt. (lbs)	Model No.
K Rigid retrieving tool that becomes flexible by removing wire rod from the shaft.	1.5 (0.681)	ZP	5/16	18	0.18	918F
L Flexible retriever w/ fixed head and nonslip solvent-resistant comfort grip	8.0 (3.628)	ZP	1/2	21	0.25	921
M1 Flexible, dual purpose allows you to get in and around awkward spots. Bend shaft to a permanent position or remove inside wire to snake into position.	3.0 (1.361)	ZP	3/8	20	0.31	928S
M2	7.0 (3.176)	ZP	5/8	20	0.35	929S
N Bendable retriever bends and holds its shape. Magnet is retracted until the button is pushed.	2.0 (0.908)	ZP	5/16	17	0.26	915RM
O Flexible retriever has a spring shaft that allows it to snake through tight areas. The magnet is retracted until the button is pushed.	2.0 (0.908)	ZP	3/8	24	0.29	922RM
P1	3.0 (1.361)	CO	5/16	25	0.11	900WF
P2 Bendable copper shaft magnetic retriever. Fits into tight spots. Knurled aluminum handle.	0.5 (0.227)	CO	0.175	20	0.08	900WFT

### Mechanical Finger Retrievers & Tools

Description	Lift - lbs	Shaft	Dia. (in)	Ln. (in)	Wt. (lbs)	Model No.
Q Flexible two jaw mechanical finger with a spring/plunger handle control. Mechanical finger span of 1".	12	ZP	3/8	17	0.25	715CF
R1 Flexible four jaw mechanical finger with a spring/plunger handle control. Mechanical finger span of 1".	10	ZP	1/2	13-1/2	0.20	612
R2		ZP	1/2	23-1/2	0.30	622
S1 Rigid two jaw mechanical finger with a spring/plunger handle control. Mechanical finger span of 1".	12	ZP	3/16	8	0.15	708
S2		ZP	3/16	12	0.22	712

Shaft Material: AL = Aluminum, CO = Copper, CP = Chrome Plated Steel, NY = Nylon, SS = Stainless Steel & ZP = Zinc Plated Steel.

## ■ Lighted Magnetic Pick-up Tool



Rare Earth, telescoping, magnetic retriever with built in light. Uses 3 LR44 watch-type batteries (included).



Description	Lift - lbs (kg)	Shaft	Magnet (in.)	Magnet Head	Ln. (in.)	Wt. (lbs.)	Model No
Lighted	22 (9.98)	Stainless Steel	11/16	Fixed	7-1/2 - 32	0.20	MRT910L

# INSPECTION MIRRORS



## Inspection Mirror & Retrieving Magnet Combination Tools

Mirror/Magnet combos have a Mirror and a powerful Rare Earth magnet on opposite ends. Use the magnet to retrieve metal items or as a magnetic base to hold the inspection mirror in place. 301G240 has a handy pocket clip. 375G990 has a flexible arm for mirror positioning.

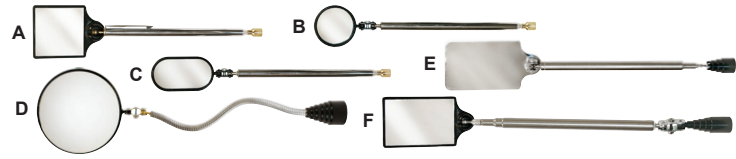

Style	Mirror (in.)	Mirror	Lift - lbs (kg)	Magnet (in)	Shaft	Ln. (in.)	Ext. Ln. (in.)	Wt. (lbs.)	Model No	Replacement Mirror
A	2 x 2	Glass	2.0 (0.908)	5/16 Dia.	Chrome Plated Brass	6-1/4	28	0.10	301G240	301RG
B	1-1/2 Dia.	Glass	2.0 (0.908)	5/16 Dia.	Chrome Plated Brass	6	23-1/2	0.10	306G240	306RG
C	2 x 1-1/4	Glass	2.0 (0.908)	5/16 Dia.	Chrome Plated Brass	6	24-1/4	0.10	315G240	315RG
D	3-7/8 Dia.	Glass	20.0 (9.072)	1-1/8 Dia.	Chrome Plated Steel	14-1/4	—	0.24	375G990	375RG
E	3 x 2	Stainless	7.0 (3.176)	5/8 Dia.	Stainless Steel	8-1/4	38	0.20	314S925	314SS-RH
F	2-1/2 x 1-7/8	Acrylic	12.0 (5.444)	1/2 Dia.	Stainless Steel	7-3/4	34-1/2	0.25	321A931	321RA

## Inspection Mirrors



These Mirrors telescope or bend, have a slim profile and have joints that can swivel and/or rotate. Models 311 & 317 have a locking hinged mirror that allows for 180° of positioning. 321S-A can be bent to a permanent position or the inside stiffening wire can be removed to snake it into position. The 3714SW is a large dolly mounted inspection mirror with swivel wheels, 3" clearance and a flashlight clip.



Style	Mirror (in.)	Mirror	Shaft	Handle/Grip Feature	Ln. (in.)	Ext. Ln. (in.)	Wt. (lbs.)	Model No	Repl. Mirror
A	7/8 Dia.	Glass	Nylon	—	8	—	0.01	302	302RG
B	1-1/2 Dia.	Glass	Chrome Plated Brass	Pocket Clip	4-1/2	24	0.07	306TR	306RG
C1	2-1/4 Dia.	Glass	Stainless Steel	Vinyl Grip-Black	7-3/4	14-1/2	0.25	309TR	309RG
C2	2-1/4 Dia.	Glass	Stainless Steel	Non-slip, solvent-resistant	7	36-1/2	0.20	309S1	309RG
D1	2 x 1-1/4	Glass	Stainless Steel	Plunger/Spring	11	—	0.18	311	311RG
D2	2-3/4 x 1-3/4	Glass	Stainless Steel	Plunger/Spring	16-1/4	—	0.20	317	317RG
E	2 x 1	Glass	Stainless Steel	Non-slip, solvent-resistant	6-1/2	36	0.17	315	315RG
F	2-3/4 x 2-1/4	Glass	Stainless Steel	Non-slip, solvent-resistant	7-1/2	36-1/2	0.15	316	316RG
G	3-1/2 x 2-1/2	Glass	Stainless Steel	Non-slip, solvent-resistant	7-1/4	37	0.21	318	318RG
H	3-7/8 Dia.	Glass	Steel	Non-slip, solvent-resistant	15-3/4	32-1/2	0.51	375	375RG
I	7 x 14	Glass	Aluminum	Vinyl bicycle grip	49	74	5.25	3714SW	3714RG
J	3-1/2 x 2	3x Glass Magnifier	Stainless Steel	Non-slip, solvent-resistant	7-1/4	36-1/2	0.18	316M	316MRG
K	2 x 2	Acrylic	Stainless Steel	Non-slip, solvent-resistant	7	35-1/2	0.21	312A	312RA
L	2-1/2 x 1-7/8	Acrylic	Stainless Steel	Non-slip, solvent-resistant	25	—	0.35	321S-A	321RA

## Stainless Steel Inspection Mirrors



Stainless Steel Mirrors are ideal for use in critical areas where foreign objects cannot be left behind. FOD (Foreign Object Debris) free. No worries about glass mirrors breaking in sensitive areas such as engines, fuel lines and machinery. Great for high heat areas. Telescoping shafts and Non-slip, solvent resistant grips on all except IMS103 & IMS105 that have Knurled Handles & bendable shafts. IMS103, IMS105 & IMS234 are non-framed and can be used in liquid/solvent applications.

Style	Mirror (in.)	Shaft	Handle Grip/Feature	Ln. (in.)	Ext Ln. (in.)	Wt (lbs)	Model No
A1	3/8 Dia.	Copper	Knurled Aluminum	11-1/2	—	0.02	IMS103
A2	1/2 Dia.	Copper	Knurled Aluminum	12	—	0.02	IMS105
B1	1-1/4 Dia.	Stain. Steel	Non-slip, solvent-resistant	7	35	0.15	IMS115
B2	2-1/4 Dia.	Stain. Steel	Non-slip, solvent-resistant	7	36	0.15	IMS123
C	2 x 1	Stain. Steel	Non-slip, solvent-resistant	7	36	0.15	IMS210
D	2 x 2	Stain. Steel	Non-slip, solvent-resistant	7	35-1/2	0.15	IMS223
E	3 x 2	Stain. Steel	Non-slip, solvent-resistant	7	37	0.18	IMS234

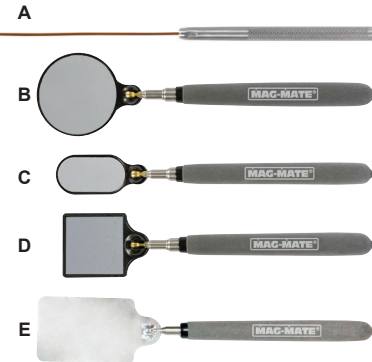

## Read Rite™ Inspection Mirror



The Read Rite™ inspection mirror shows the numbers, letters and more as they would appear if they were visually accessible by the eye (non-inverted), eliminating deciphering or transcription errors and providing the utmost accuracy in observation. Using a typical inspection mirror to read important numbers can lead to uncertainty or inaccuracy due to the inverted appearance of the image.

- Stainless Steel Mirror - No glass to break
- Dual-sided: Read Rite™ mirror on one side, regular inspection mirror on the other side
- Telescoping Hex rod shaft prevents mirror from swinging while in use
- Double Ball Hinge with adjustable tension, 360° rotation

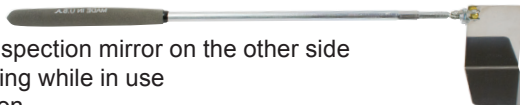

Mirror (in.)	Mirror	Shaft	Handle/Grip Type	Ln. (in.)	Ext. Ln. (in.)	Wt. (lbs.)	Model No	Replacement Mirror
3-1/2 x 2	Stainless Steel	Zinc Plated	Non-slip, solvent-resistant	15-1/2	28-1/2	0.50	390SS	390RS

# INSPECTION KITS & MAGNETIC RETRIEVERS



## Inspection Mirrors - HiVis Orange

These telescoping mirrors have a slim profile, joints that can swivel and/or rotate and have highly visual orange grips and/or heads. Never leave a tool behind! 301G240HVO had a retrieving magnet at the opposite end that can lift 2 lbs and has a handy pocket clip. IMS123HVO contains a stainless steel mirror for use in critical areas where foreign objects cannot be left behind. FOD (Foreign Object Debris) free. Handles are Non-slip, solvent resistant cushion grips.

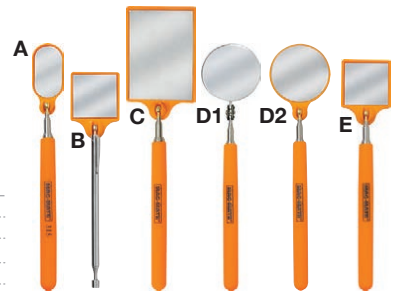

Style	Mirror (in)	Mirror	Shaft	Ln. (in)	Ext. Ln. (in)	Wt. (lbs)	Model No.
A	2 x 1	Glass	Stainless Steel	6-1/2	36	0.17	315HVO
B	2 x 2	Glass	Chrome Plated Brass	6-1/4	28	0.10	301G240HVO
C	3-1/2x2-1/2	Glass	Stainless Steel	7-1/4	37	0.21	318HVO
D1	2-1/4 Dia	Glass	Stainless Steel	7	36-1/2	0.20	309S1HVO
D2	2-1/4 Dia	Stainless	Stainless Steel	7	36	0.15	IMS123HVO
E	2 x 2	Acrylic	Stainless Steel	7	35-1/2	0.21	312AHVO



## Lighted Inspection Mirror

This telescoping glass mirror contains 3 LED lights that pivot to shine the light exactly where you need it. Mirror is on a double ball joint. Batteries included.



Mirror (in)	Mirror	Shaft	Handle/Grip Feature	Ln. (in)	Ext. Ln. (in)	Wt. (lbs)	Model No.	Repl. Mirror
2-3/4 x 1-7/8	Glass	Stainless Steel	Non-slip, Solvent Resistant	7-1/2	35	0.25	IMG238L	N/A

## Inspection Tool Kits



Best of both worlds when you package a telescoping mirror or magnifier with a telescoping Rare Earth magnetic retriever in a foam-lined snap-lock case. These tools have a nonslip, solvent-resistant grip.

*Note: MMK200 is Non-telescoping, Non-conductive (Nylon construction, including the grip), and does not come in a case. MMK301 contains a Lighted Magnet pick-up tool, 4-Jaw, 7/16" dia., 8-3/4" Mechanical Finger retriever and a Round Magnifying Inspection Mirror.*



Mirror / Magnifier (in.)	Mirror	Lift - lbs (kg)	Shaft	Mirror / Magnifier Length (in.)	Magnet (in.)	Magnet Head	Magnet Ln. (in.)	Wt. (lbs.)	Model No
1-1/2 dia.	Glass	1 (0.45)	Nylon	8-1/4	5/16 Dia.	Swivel	8-1/4	0.05	MMK200
1-3/4 x 2-1/2	Acrylic	14 (6.35)	Stainless	7-1/2 - 34	5/8 Dia.	Fixed	7-1/2 - 34	0.60	MMK201
1-3/4 x 2-1/2	3X Glass Magnifier	14 (6.35)	Stainless	7-1/2 - 34	5/8 Dia.	Fixed	7-1/2 - 34	0.60	MMK202
1-3/4 x 2-1/2	Acrylic	14 (6.35)	Stainless	7-1/2 - 34	5/8 Dia.	Swivel	7-1/2 - 34	0.60	MMK203
1-3/4 x 2-1/2	3X Glass Magnifier	14 (6.35)	Stainless	7-1/2 - 34	5/8 Dia.	Swivel	7-1/2 - 34	0.60	MMK204
2-1/2 dia.	3X Glass	22 (9.97)	Stainless	7 - 36	11/16 Dia.	Lighted/Fixed	7-1/2 - 32	0.90	MMK301

## Long Reach Retrievers



Ideal for reaching behind, underneath or around machinery and/or difficult to reach areas. These tools have a maximum temperature of 300°F (148°C). The MX3000WAH lightweight long reach retriever has a round magnet at a 45 degree angle. The MM06X38 is a long retriever for narrow areas with a rectangular magnet.

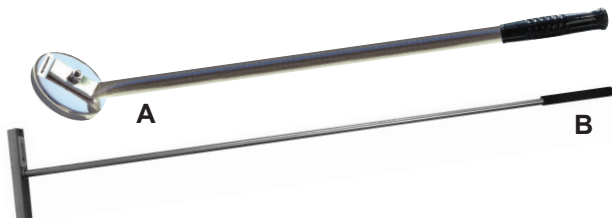

Lift - lbs (kg)	Magnet Dimensions (in)	Ln. (in)	Wt. (lbs)	Model No.
A 47.5 (21.55)	3-1/4 Diameter	38	1.70	MX3000WAH
B 8.0 (3.63)	1-3/8 x 6	40	3.00	MM06X38

## ON/OFF Magnetic Utility Lifter

Stop bending over to lift and move steel pieces and scrap.

Reduce finger and toe injuries with this lightweight deep reach permanent magnetic lifter.

This Magnetic Utility Lifter has a locking On/Off handle for safety and makes moving steel quick and easy.



Lift - lbs (kg)	Height (in)	Width (in)	Length (in)	Wt. (lbs)	Model No.
50.0 (22.68)	28-1/2	5-1/2	3-1/2	7.65	MCLVB01
75.0 (34.02)	28-1/2	7	5	15.10	MCLVB02

# WELDING ANGLES & CLAMPING DEVICES



## Magnetic Welding Squares

### Features

- Ideal for welders that need fast set-up and accurate holding of steel at multiple angles
- Hold work pieces at multiple angles
- Finger hole(s) for safer and easier use
- 5/16" Mounting holes for fixturing
- Plated steel poles reduce rust
- WS420, WS810 & WS820 models feature "Breakaway Handle"\*
- Weld spatter and fuzz iron resistant covers on certain models\*\*

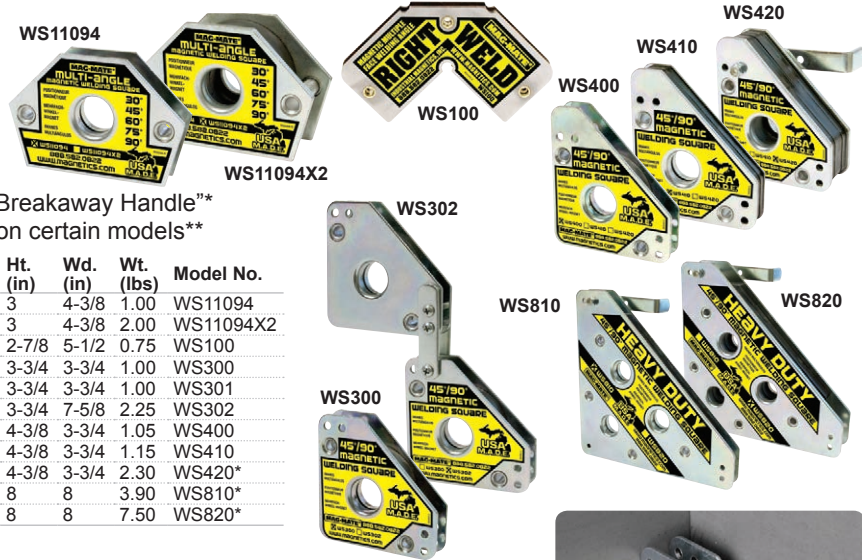

Max Hold - lbs (kg)	Description	Thick. (in)	Ht. (in)	Wd. (in)	Wt. (lbs)	Model No.
55 (24.95)	Multi-Angle	3/4	3	4-3/8	1.00	WS11094
110 (49.89)	Multi-Angle, Extra Power	1-9/16	3	4-3/8	2.00	WS11094X2
40 (18.14)	Inside 90°, Outside 45°/90°	5/8	2-7/8	5-1/2	0.75	WS100
60 (27.21)	Compact	3/4	3-3/4	3-3/4	1.00	WS300
60 (20.21)	Compact Multi-Angle	3/4	3-3/4	3-3/4	1.00	WS301
120 (54.43)	Adjustable	1-3/8	3-3/4	7-5/8	2.25	WS302
75 (34.02)	Mid-Size	3/4	4-3/8	3-3/4	1.05	WS400
75 (34.02)	Mid-Size, Covered**	3/4	4-3/8	3-3/4	1.15	WS410
150 (68.04)	Mid-Size, Extra Power Covered**	1-1/2	4-3/8	3-3/4	2.30	WS420*
160 (72.58)	Large, Covered**	3/4	8	8	3.90	WS810*
325 (147.42)	Large, Extra Power Covered**	1-1/2	8	8	7.50	WS820*

### Magnetic Welding 3-Axis Holding

- Permanent Welding Square holds 3 pieces of metal at once
- Ideal for holding support brackets, gussets, etc.
- Third side has 42lb max hold
- WS410AX3 has weld spatter, fuzz iron resistant cover

Max Hold - lbs (kg)	Description	Thick. (in)	Ht. (in)	Wd. (in)	Wt. (lbs)	Model No.
55 (24.95)	Multi-Angle	1-1/8	3	4-3/8	1.00	WS11094AX3
60 (27.21)	Compact	1-1/8	3-3/4	3-3/4	1.00	WS300AX3
60 (20.21)	Compact Multi-Angle	1-1/8	3-3/4	3-3/4	1.00	WS301AX3
75 (34.02)	Mid-Size	1-1/8	4-3/8	3-3/4	1.05	WS400AX3
75 (34.02)	Mid-size Covered	1-1/8	4-3/8	3-3/4	1.20	WS410AX3



## Mag90™ ON/OFF Magnetic Squares

On/Off Switchable Permanent Rare Earth Magnetic Squares are extremely powerful and eliminate the need for tedious clamping. The Mag90™ squares offer fast work-holding on multiple sides for flat or round steel. Features pre-tapped holes on all sides for mounting and a locking On/Off handle for safety.



Max Hold - lbs (kg)	Flat Steel	Round Steel	Min Dia. (in)	Overall Ht. (in)	Ht. (in)	Wd. (in)	Ln. (in)	Tap	Tap Depth (in)	Wt. (lbs)	Model No.
150 (68.04)	75 (34.02)	1-1/2	2-3/4	1-1/8	1-1/2	1-1/2	1-1/2	#8-32	0.330	0.80	WS0150R
450 (204.12)	225 (102.06)	2	4-5/8	2-3/4	2-1/2	3	3	1/4-20	0.500	4.30	WS0450R
1000 (453.60)	500 (226.79)	4	4-3/4	3	4	4-1/4	4-1/4	3/8-16	0.625	10.45	WS1000R

## ON/OFF Magnetic Welding Angles

On/Off Switchable Permanent Rare Earth Magnetic Welding Angles welders set up, weld and quickly move on to the next project. Simply place on work surface, turn on and start welding. On/Off magnets easily allows debris to fall away. Can be used on flat or round steel or cast iron. Non-marring hold. Stainless steel construction.

### Features

- Pivoting Magnetic Welding Angles pivot to angles ranging from 22° to 270°, with locking handle and detents. Hold on 3 sides.
- 90° Magnetic Welding Angles have slots allowing for quick-slide adjustment or addition of more magnetic bases. Reversible for inside or outside hold.
- WSF275X3 ON/OFF holds 3 sides.

Max Hold - lbs (kg)	Angle Type	Height (in)	Width (in)	Length (in)	Weight (lbs)	Model No.
150 (68.04)	Pivoting	9-5/8	2-1/8	9-5/8	4.30	WSP0150R
150 (68.04)	90°	8-1/4	2-7/8	8-1/4	3.60	WSF0150R
450 (204.12)	90°	12-1/4	3-7/8	12-1/4	6.80	WSF0450R
275 (124.74)	90°	7-1/4	1-5/8	7-1/4	5.00	WSF275X3



## ON/OFF Switchable Magnetic Welding Squares

### Features

- 5 common angles: 45, 75, 90, 105 & 135 degrees
- WSM0150RG is a dual purpose tool, utilizing multi-angle weld square and a 300 AMP welding ground all in one. Fits 1/2 inch bolt.
- Stays clean and chips fall off easily when magnet is turned off
- Heat resistant up to 180°F (82°C)

Max Hold- lbs (kg)	Ht. (in)	Wd. (in)	Ln. (in)	Wt. (lbs)	Model No.
80 (36.28)	3-1/2	1-15/16	3-1/2	1.45	WSM0150R
150 (68.04)	3-3/4	1-15/16	4	1.60	WSM0150RG



## ON/OFF Magnetic Weld Grounds

On/Off Switchable Permanent Rare Earth Magnetic Grounds let welders set up, weld and quickly move on to the next project. Makes welding quicker and easier than ever before. Will work on flat or pipe.

Bolt: 1/2-13 x 1-1/4" Lg



Max Hold - lbs (kg)	Ht. (in)	Wd. (in)	Ln. (in)	Amps	Wt. (lbs)	Model No.
150 (68.04)	2-3/4	1-13/16	2-7/8	200	0.90	WG200R
150 (68.04)	2-3/4	1-15/16	2-7/8	300	0.95	WG300R
450 (204.12)	4-5/8	3	5	800	4.90	WG800R

## ON/OFF MagPry™

Strong, easy to use, On/Off switchable magnetic pry bar for material leveling and alignment also known as mismatch or high / low allowing for rapid and easy plate matching for seamless welds on flat and pipe. Perfect for all plate and seam work, under foot, on vertical surfaces, even overhead. The Mag-Pry™ eliminates need for welded tabs. Up to 100 times faster than dogs and wedges saving you time and money, pays for itself in days. Non-marring.



Max Hold - lbs (kg)	Ht. (in)	Wd. (in)	Ln. (in)	Wt. (lbs)	Model No.
1000 (453.60)	3-1/2	5-7/8	19	10.0	PB1000R

## Magnetic Welding Wind Block

### Features

- Powerful permanent magnets
- Prevents loss of gas coverage
- Stainless steel with flat black finish
- Reduces arc flash
- Spring load holds tight to surface, horizontally, vertically or inverted

Hold - lbs (kg)	Overall Ht. (in)	Ht. (in)	Wd. (in)	Ln. (in)	Wt. (lbs)	Model No.
50 (22.68)	8.33	7.09	2.88	24	2.50	WWB24
50 (22.68)	8.33	7.09	2.88	36	3.00	WWB36



## Welding Ground Clamp

### Features

- Dual-purpose workpiece clamp and welding ground
- No-twist clamp secures workpiece without twisting or "walk-off-center"
- Copper plated spindle and clamp jaws prevent weld splatter from sticking
- Clamp jaws are beveled to hold both flat or round surfaces
- Deep throat jaw allows for deep clamping of material

Jaw Depth (in)	Ln. (in)	Wd. (in)	Th. (in)	Amps	Wt. (lbs)	Model No.
4-1/2	9	4-7/16	1-1/8	400	1.90	WGC4.5DTP



## Weld Torch Holders

### Features

- Securely and neatly hold welding torch in place on the top, side or underside of work bench or nearby steel structure
- Stainless steel holder, plated steel magnetic base
- Magnetic base allows for quick and easy repositioning



Hold - lbs (kg)	Magnet Dia. (in)	Torch Type	Ht. (in)	Wd. (in)	Wt. (lbs)	Model No.
41 (18.59)	2.63	TIG	6-3/4	3-1/8	0.75	WTHHT01
47.5 (21.54)	3.18	MIG	5-3/4	4	0.90	WTHM01

## Magnetic Welding Grounds

### Features

- Powerful magnet attaches securely to steel work surfaces
- Spring loaded 1/2" dia. stud assures constant electrical ground contact
- Release handle



Hold - lbs (kg)	Dia. (in)	Ht. (in)	Amps	Stud	Wt. (lbs)	Model No.
35 (15.88)	3-1/2	2-1/4	250	Brass	1.50	WG250
35 (15.88)	3-1/2	2-1/4	800	Copper	1.50	WG800

# MAGNETS FOR HOLDING & STORAGE



## ON/OFF Magnetic Hanging Hooks

On/Off Switchable Permanent Rare Earth Magnetic hanging hooks are perfect for temporary holding of lines, hoses, lights, tools and more. Quickly secure and hold just about anything, anywhere with unique fast hook technology.

### Features

- Sides can hold nuts, bolts, screws etc. when magnet is turned "ON"
- Attaches to flat or round surfaces either one of two sides
- Unique hook design prevents lines and hoses from popping off
- Locking On/Off Handle



Hold - lbs (kg)	Projects (in)	Wd. (in)	Ln. (in)	Wt. (lbs)	Inside Loop		Model No.
					Ln. (in)	Wd. (in)	
35 (15.88)	2-3/4	1-3/4	5-3/4	0.95	1-5/8	1-1/8	HH035R
110 (49.90)	4-5/8	2-1/2	7-5/8	4.65	1-7/8	1-3/8	HH110R

## Magnetic Reversible Hook

### Features

- Secures cables, wire, lights, garments and more to any flat steel surface.
- Magnet can be quickly installed and repositioned.
- Stainless steel hook can be used in the "open" position for quick access to store product.
- Move the hook to "closed" position to prevent products from being knocked off.
- Overall length 4.5"



Hold - lbs (kg)	Overall Ht. (in)	Magnet Dia. (in)	Hook Base Depth (in)	Hook Tip Ln. (in)	Hook Width (in)	Wt. (lbs)	Model No.

## Universal J-Hooks

Use J-Hooks to hold cables, wires, tubing, etc. to steel walls, ceilings or beams. Powerful magnet can be mounted on the hook in either of two positions for wall or ceiling installation.

### Features

- Magnet can be quickly installed and repositioned.
- Sturdy Stainless-Steel hook.

*Note: Use lightweight telescoping pole to install J-hooks instead of climbing ladders. Makes setting J-hooks fast and easy on wall or ceiling installations. Aluminum/Fiberglass pole extends from 6' to 12'. Model Number: TSP6-12.*

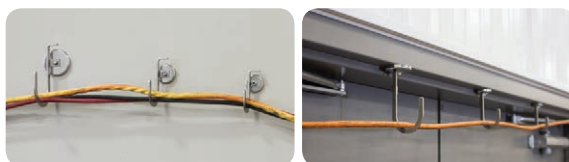

MAX Hold Lbs. (kg)	Dia. (in)	Overall		Open Range (in)	Wt. (lbs)	Model No.
		Ln. (in)	Proj. (in)			
15 (6.80)	1.24	3.12	2.00	1.0 x 1.0	0.10	MX1000JH
25 (11.34)	1.41	3.87	2.75	1.5 x 1.5	0.15	MX1500JH
42 (19.05)	2.03	5.00	3.25	2.0 x 2.0	0.25	MX2000JH

## Can/Cup Holders

Hold your can, cup, bottle, lubricant spray, etc. where you want it. Take it with you when you move from one machine to another or anywhere there is a metal surface. Holds well on ferrous metal surface, even painted or plated surfaces.

### Features

- Sturdy Stainless Steel holder
- Plated Permanent Ceramic Cup Magnet
- Holds diameters up to 3-3/8" with or without a handle



Hold - lbs (kg)	Ht. (in)	Wd. (in)	Projects	Wt. (lbs)	Model No.
41.0 (18.60)	3-1/2	4-1/4	4-1/4	0.85	CCH01
82.0 (37.2)	3-1/2	8-1/4	4-1/4	2.10	CCH02
82.0 (37.2)	3-1/2	12	4-1/4	2.95	CCH03

## Impact Wrench/Heat Gun Holder

Ideal for holding heavy impact wrenches, heat guns or any similar shaped tools that need to be kept handy. Powerful permanent magnet holds extremely well on steel surfaces. The thicker the steel the better the hold.

### Features

- Powerful Permanent Magnet
- Sturdy Stainless-Steel Holder
- Holds diameters up to 3-3/8"
- Heat resistant up to 300°F (148°C)



MAX Hold Lbs. (kg)	Ht. (in)	Wd. (in)	Projects (in)	Wt. (lbs)	Model No.
140 (63.50)	3.18	4.25	4.5	0.85	IWH01

## Hose Cord Hook/Holder

### Features

- Secure hoses, cables, cords and more to any flat, steel surface
- Magnet can be quickly installed and repositioned
- Sturdy stainless steel hook
- Small holder secures ends of hose/cord from unravelling



Hold lbs (kg)	Project (in)	Magnet Dia. (in)	Hook Base Depth (in)	Hook Tip Ln. (in)	Hook Wd. (in)	Wt. (lbs)	Model No.

# MAGNETS FOR HOLDING & STORAGE



## Grinder Tool Holder



Keep your grinder handy on top or side of steel work benches. Powerful permanent magnet holds 4" diameter grinder wheels in horizontal or vertical positions, regardless of trigger location.



### Features

- Sturdy stainless steel holder
- Plated permanent ceramic magnet
- Magnetic base allows for quick placement and repositioning

Hold - lbs (kg)	Ht. (in)	Wd. (lbs)	Ln. (in)	Wt. (in)	Model No.
41.0 (18.59)	6	4-3/8	9-1/8	1.20	GTH01

## Spray Gun Holder



Keep your spray gun handy inside your paint booth! This magnetic Spray Gun Holder sticks through many layers of paint to hold your spray gun. Easily moved when necessary.

### Features

- Sturdy Stainless Steel holder
- Plated Permanent Ceramic Cup Magnet



Holds - lbs (kg)	Ht. (in)	Wd. (in)	Projects	Wt. (lbs)	Model No.
95 (43.09)	4.9	4.9	5.5	1.75	SGH01

## Flexible Flashlight Holder

When you need to use both hands and there is nobody to hold a light for you, these magnetic based flexible flashlight holders will come to the rescue. Strong magnetic hold is easily repositioned. Flexible neck lets you pinpoint the light right where you need it. MX25FLVB02 fits typical Mag-Lite® flashlights. Flashlights not included.

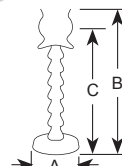
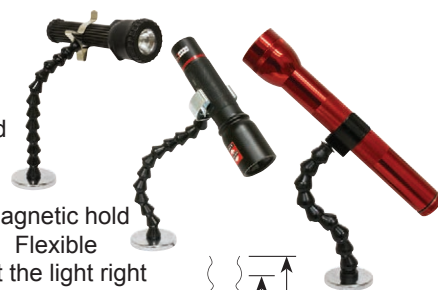

MAX Hold Lbs. (kg)	Open Range (in)	A (in)	B (in)	C (in)	Wt. (lbs)	Model No.
42 (19.1)	0.62 - 1.25	2.03	8.50	7.87	0.25	MX20FLNP01
42 (19.1)	1.00 - 1.50	2.03	9.00	8.00	0.25	MX20FLZP01
80 (36.3)	1.50 - 1.87	2.63	10.75	9.75	0.55	MX25FLVB02

## Air Chuck Holder



Never search for your chuck and other fitting again. Holder keeps important fitting conveniently on your hose.

### Features

- Fits typical 3/8" hose
- 3 holders in a pack



Hose Dia. (in)	Fitting	Ht. (in)	Wd. (in)	Ln. (in)	Wt. (lbs)	Model No.
3/8	1/4	1-1/2	7/8	1-1/2	0.05	ACH1/4

## Portable Magnetic Holders

Secure brooms, flashlights, spray cans, markers, etc. to any steel surface without drilling to install clips/holders. These powerful permanent magnets are quickly installed and repositioned when needed. Keep critical tools for the job handy.



Style	Max Hold - lbs (kg)	Description	Magnet	O.D. (in)	Opening (in)	Magnet I.D. (in)	OAH (in)	Wt. (lbs)	Model No.
A	15.0 (6.80)	Nickel Plated Clamp	Ceramic	1.24	0.19 - 0.38	0.25	0.88	0.05	MX1000NP01
A	25.0 (11.34)	Nickel Plated Clamp	Ceramic	1.41	0.31 - 0.75	0.375	1.53	0.10	MX1500NP01
A	42.0 (19.05)	Nickel Plated Clamp	Ceramic	2.03	0.63 - 1.25	0.859	2.31	0.19	MX2000NP01
A	80.0 (36.29)	Nickel Plated Clamp	Ceramic	2.63	1.00 - 1.88	1.00	2.50	0.41	MX2500NP01
A	15.0 (6.80)	Stainless Steel Clamp	Ceramic	1.24	0.38 - 0.50	0.25	1.09	0.05	MX1000SS01
A	25.0 (11.34)	Stainless Steel Clamp	Ceramic	1.41	0.63 - 0.88	0.375	1.91	0.11	MX1500SS01
A	25.0 (11.34)	Stainless Steel Clamp	Ceramic	1.41	0.88 - 1.13	0.375	2.03	0.10	MX1500SS02
A	25.0 (11.34)	White Plastic Coated Clamp	Ceramic	1.41	0.31 - 0.75	0.375	1.66	0.10	MX1500WP03
A	25.0 (11.34)	White Plastic Coated Clamp	Ceramic	1.41	0.56 - 0.88	0.375	1.28	0.09	MX1500WP01
A	42.0 (19.05)	White Plastic Coated Clamp	Ceramic	2.03	0.63 - 1.25	0.859	2.31	0.19	MX2000WP01
A	80.0 (36.29)	White Plastic Coated Clamp	Ceramic	2.63	1.00 - 1.88	1.00	2.88	0.41	MX2500WP01
B	42.0 (19.05)	Black Vinyl Coated Clamp	Ceramic	2.03	1.50 - 1.88	0.859	2.19	0.19	MX2000VB02
C	15.0 (6.80)	Zinc Plated Clamp	Ceramic	1.24	0.38 - 0.63	0.25	1.13	0.06	MX1000ZP01
C	25.0 (11.34)	Zinc Plated Clamp	Ceramic	1.41	0.75 - 1.13	0.375	1.53	0.13	MX1500ZP01
C	25.0 (11.34)	Zinc Plated Clamp	Ceramic	1.41	1.00 - 1.50	0.375	1.53	0.19	MX1500ZP02
C	15.0 (6.80)	Black Vinyl Coated Clamp	Ceramic	1.24	0.38 - 0.63	0.25	1.13	0.06	MX1000VB01
C	25.0 (11.34)	Black Vinyl Coated Clamp	Ceramic	1.41	0.75 - 1.13	0.375	1.53	0.13	MX1500VB01
C	19.0 (8.62)	Black Vinyl Coated Clamp	Ceramic	2.03	2.00 - 2.50	0.859	2.31	0.22	MX2000VB01
D	15.0 (6.80)	Black Plastic Clamp	Ceramic	1.24	0.87 - 1.13	0.25	0.98	0.05	MX1000BP01
D	25.0 (11.34)	Black Plastic Clamp	Ceramic	1.41	1.13 - 1.38	0.375	1.25	0.10	MX1500BP01
D	42.0 (19.05)	Black Plastic Clamp	Ceramic	2.03	1.87 - 2.13	0.859	2.06	0.20	MX2000BP01
E	42.0 (19.05)	Red Vinyl Coated Hook	Ceramic	2.03	1.38	0.859	2.44	0.20	MX2000RV01
F	80.0 (36.29)	Black Rubber Spring Clamp	Ceramic	2.63	0.87 - 1.25	1.00	1.13	0.65	MX2500BH01

# TOOL STORAGE & SQUARING ARMS



## Air Tool Holders/Rack



Keep all your air tools organized, neat and handy with this one-piece sturdy rack. Available in three different lengths with slots for 1/4" or 3/8" air tool male couplers.

### Features

- Sturdy all Stainless Steel construction
- Versatile mounting flange
- Beveled flange to keep tools from vibrating off
- Wide shelf for storage of other tools such as sockets



Coupler Size	Ht. (in)	Wd. (in)	Projects	No. of Slots-Holes	Wt. (lbs)	Model No.
1/4	1-1/2	12	4	5-4	1.75	ATH12-1/4
3/8	1-1/2	12	4	5-4	1.75	ATH12-3/8
1/4	1-1/2	24	4	11-10	3.50	ATH24-1/4
3/8	1-1/2	24	4	11-10	3.50	ATH24-3/8
1/4	1-1/2	48	4	15-14	7.00	ATH48-1/4
3/8	1-1/2	48	4	15-14	7.00	ATH48-3/8

## Magnetic Tool Holders



### Features

- Industrial strength keeps tools close at hand and organized
- Mount to walls, work benches, ladders, etc.
- Versatile mounting flange with screws provided
- Durable stainless steel construction
- Holds a 10 Lb. Hammer!
- USA M.A.D.E.™



Hold - lbs (kg)	Projects (in)	Ln. (in)	Wt. (lbs)	Model No.
120.0 (54.44)	2	12	2.00	TH1200
180.0 (81.65)	2	18	3.00	TH1800
240.0 (108.87)	2	24	4.00	TH2400

## Magnetic Squaring Arm for Press Brakes



Perform 90 degree and angled bends faster, safer and more accurately. This squaring arm magnetically attaches to the flat surface of the die without tools. The Magnetic Squaring Arm for Press Brakes features an adjustable arm that can swing 140 degrees allowing for quick and easy part positioning on the left or right to accommodate part requirements.

This Magnetic Squaring Arm improves safety for press brake operates working with small parts. Sturdy platform and a magnetic arm holds parts, keeping operators fingers clear of the press.

### Features

- Powerful Rare Earth Magnets hold tight to die
- Arm swings from 90° to 20° in two directions allowing for 140° swing in total
- Arm is magnetic to hold small steel pieces, keep fingers away
- Adjustable handle secures arm at proper angle and moves out of the way
- Locator rule on leading edge helps locate squaring arm
- Stainless Steel/Aluminum construction
- Safety strap prevents squaring arm from falling off if accidentally knocked off die

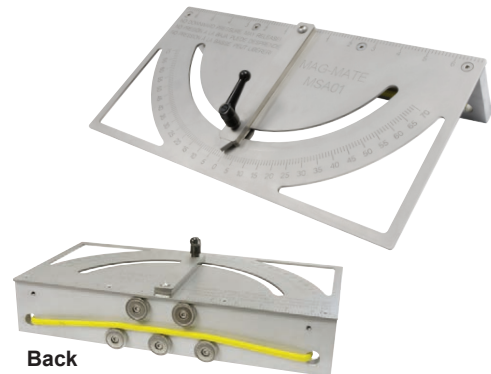

Hold - lbs (kg)	Ht. (in)	Wd. (in)	Ln. (in)	Wt. (lbs)	Model No.
90 (40.82)	2-5/8	7-1/4	14	5	MSAP01

## Magnetic Squaring Arm for Shears



Maximize shear efficiency by utilizing the entire shear blade for uniform wear and perform angle cuts. On/Off magnets allow for fast setup with a standard framing square. For extra strength, an additional magnet can be added in the center. For short bed depths, one magnet can be moved to the center hole.

### Features

- Powerful On/Off Permanent Rare Earth Magnets
- Adjustable magnet locations or add another magnet
- Stainless Steel construction



Hold - lbs (kg)	Overall Ht. (in)	Edge Ht. (in)	Wd. (in)	Ln. (in)	Wt. (lbs)	Model No.
300 (136.07)	2-5/8	3/4	2-1/4	12	2.25	MSAS01

# CUTTING TABLE TOOLS & RETRIEVERS



## RapidFire Retriever®



### Features

- Retrieve hot parts off cutting tables with speed & precision!
- Increase production while reducing the potential for injury
- Powerful Rare Earth Magnet holds part securely
- "On-Command" release with just a quick blast of shop air
- Actuate release with just one finger, it's as simple as the pull of a trigger



Lift - lbs (kg)	Ln. (in)	Wt. (lbs)	Model No.
35.0 (15.88)	24	2.1	RFR2400
35.0 (15.88)	36	2.3	RFR3600
35.0 (15.88)	48	2.5	RFR4800
16.0 (7.40)	7	0.5	RFR7-15
35.0 (15.88)	7	0.8	RFR7-30

## Power Grip



### Features

- Effective holding against shear force
- Securely grips heavy parts
- Maximum Temp. 300°F (148°C)



Lift - lbs (kg)	Ht. (in)	Wd. (in)	Ln. (in)	Poles	Wt. (lbs)	Model No.
25.0 (11.34)	2	3/4	2-1/8	2	0.40	AC2100WLH
51.5 (23.36)	2-1/4	3/4	4	2	0.75	AC2200WLH
92.5 (41.96)	2-3/4	1-7/8	5-1/4	4	1.80	AC2201WLH

## Magnetic TriggerLift®



Hand held lift grips parts with an easy to use trigger release.

### Features

- Retrieve hot parts from cutting tables
- One handed operation
- Permanent magnet
- Move parts faster and easier
- Aluminum housing
- Maximum Temp. 300°F (148°C)

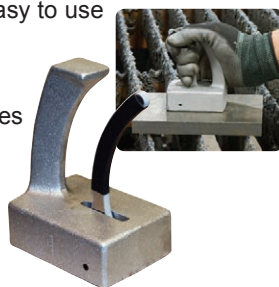

Lift - lbs (kg)	Ht. (in)	Wd. (in)	Ln. (in)	Wt. (lbs)	Model No.
50.0 (22.68)	4-13/16	2-3/8	3-3/8	1.50	B090

## Magnetic Sheet Handlers

### Features

- Lift or move sheets, plates, hot or oily parts
- Handle sheets stacked horizontally or vertically
- Protect workers from cuts, slivers, nicks & burns
- Increase productivity

Note: Not intended to be used with a crane

Lift - lbs (kg)	Th. (in)	Wd. (in)	Handle Ln. (in)	Overall Ln. (in)	Mag. Ln. (in)	Mag. Th. (in)	Wt. (lbs)	Max. Penetration (in)	Model No.
50.0 (22.6)	4	3-5/8	8	11-1/2	6-1/8	1-3/8	3.75	3/16	B100
125.0 (56.7)	4	7-1/4	8	11-1/2	6-1/8	1-3/8	8.25	5/16	B250
200.0 (90.7)	4	7-1/4	8	11-1/2	6-1/8	1-3/8	8.25	5/16	B400
300.0 (136.0)	4	7-1/4	8	11-1/2	6-1/8	1-3/8	8.25	5/16	B600

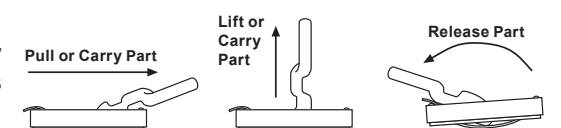

## Grip Stick Retriever



### Features

- Reduce employee injury by keeping hands out of press
- Magnet & Grip ends are interchangeable.
- Retrieve hot parts
- 10° angled handle



Lift - lbs (kg)	Type	Ht. (in)	Wd. (in)	Ln. (in)	Wt. (lbs)	Model No.
12.5 (5.67)	Low Profile	7/8	1-3/8	14	0.65	IMPL2100
43.5 (19.73)	Low Profile	7/8	1-3/8	14	0.65	IMPL2104
40.0 (18.14)	Heavy Duty	1-7/8	7/8	14	0.90	IMPL3040
60.0 (27.21)	Heavy Duty	1-7/8	1-7/8	14	1.05	IMPL3060

## Power Grip Plus



### Features

- Securely grips heavy/hot/sharp parts
- Lightweight, non-conductive nylon handle
- Easy side-roll release
- Maximum Temp: Ceramic 300°F (148°C), Neodymium 180°F (82°C), Samarium Cobalt 392°F (200°C)



Note: Magnet Length 6"  
Magnet Width 0.56"

Lift - lbs (kg)	Magnet Type	Ht. (in)	Wd. (in)	Ln. (in)	Wt. (lbs)	Model No.
50 (22.68)	Ceramic	5	2.17	7.5	2.6	PG2050C
180 (81.65)	Neodymium	5	2.17	7.5	2.6	PG2180N
110 (49.90)	Samarium	5	2.17	7.5	2.6	PG2110S

## ON/OFF Power Grip

### Features

- Switchable Rare Earth Magnet
- Securely grips heavy parts
- Works on flat or pipe
- Max. Temp. 180°F (82°C)
- Locking On/Off Handle
- Comfort Grip

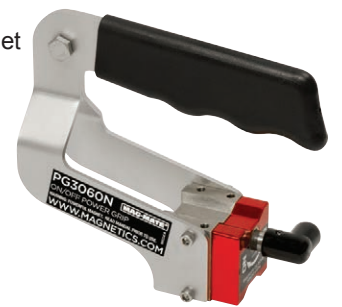

Lift lbs (kg)	Round lbs (kg)	Ht. (in)	Wd. (in)	Ln (in)	Magnet Wd. (in)	Magnet Ln (in)	Wt. (lbs)	Model No.
60 (27.22)	30 (13.61)	5	2	6	1-1/2	1-1/4	1.65	PG3060N
100 (45.36)	50 (22.68)	7-3/4	3-3/8	7-1/2	2-1/2	2	5.65	PG3100N

Lift value on pipe varies based on diameter and wall thickness.



# PERMANENT CERAMIC MAGNETIC LIFTS



## BasicLift™ Magnets

The BasicLift™ is a powerful, no frills permanent ceramic lift magnet perfect for basic flat steel lifting, angle iron, square tubes, etc. Featuring a lightweight and durable Stainless Steel design, the BasicLift™ has a full width cam to release the magnet from the steel surface and a tall lift lug for easy use with crane hooks and slings.

The BasicLift™ offers a good value for your dollar with strong lifting capacity and basic lifting features.

### Features

- Lightweight Design
- Durable Stainless Steel Casing
- Large Lift Lug
- Full Width Cam Release
- Heat resistant up to 300°F (148°C)
- 2:1 Design Factor



Model No.	WLL		Overall				Magnet			Bail Opening			Wt. (lbs)
	LBS	KG	Ht. (in)	Wd. (in)	Ln. (in)	Handle (in)	Ht. (in)	Wd. (in)	Ln. (in)	Th. (in)	Ht. (in)	Wd. (in)	
BL0400	400	181	5-1/2	5-5/8	7-1/2	12	1-5/8	4-1/2	3	1/4	2-3/4	2-3/4	11
BL1000	1000	453	5-1/2	5-5/8	11	12	1-5/8	4-1/2	6-1/2	1/4	2-3/4	2-3/4	17
BL1500	1500	680	5-1/2	5-5/8	14-1/2	12	1-5/8	4-1/2	10	1/4	2-3/4	2-3/4	24

Working Load Limit (WLL) in lbs (kg) & *Maximum Sheet Length Due To Sag For Material Thickness For Single Magnet Use								
Model No.	3/16" (6' Length)	1/4" (6' Length)	3/8" (8' Length)	1/2" (8' Length)	3/4" (8' Length)	1" (10' Length)	3" (10' Length)	
BL0400	375 (170)	400 (181)	400 (181)	400 (181)	400 (181)	400 (181)	400 (181)	400 (181)
BL1000	725 (328)	800 (362)	875 (396)	975 (442)	1000 (453)	1000 (453)	1000 (453)	1000 (453)
BL1500	875 (396)	1000 (453)	1400 (635)	1400 (635)	1500 (680)	1500 (680)	1500 (680)	1500 (680)

**NOTE:** Lifting Values for the BasicLift™ Magnets are stated at 50% of the actual value. We recommend when lifting sheets over 8', use 2 or more lifts on a spreader bar to prevent sheet flexing, sagging or peel-off. Thin material is susceptible to magnetic bleed through, resulting in two sheets being lifted at once. \*These maximum sheet lengths are selected due to the sag characteristics of the specified sheet. The item to be lifted must cover the entire length and width of the magnetic poles to properly engage and release the part.

## Creative Lift® Magnets



Permanent lift magnets are ideal for handling steel plates, die castings, forgings, etc. They eliminate the need for clamping devices, slings or chains. One person can perform operations previously calling for two or more people.

### Features

- Patented Non-Marring Roller Cam Release will easily release parts without gouging your valuable materials (U.S. Patent: 6,471,273 B1)
- Spring return handle
- Less torque required to release load
- "Jack Screw", Secondary Release
- RFID Enabled
- Lift capacity clearly stated on magnet
- Durable Stainless Steel Casing
- Heat Resistant up to 300°F (148°C)
- 3:1 Design Factor
- ASME B30.20 BTH-1 Design Category B Service Class 3



Model No.	WLL		Overall				Magnet			Bail Opening			Wt. (lbs)
	LBS	KG	Ht. (in)	Wd. (in)	Ln. (in)	Handle (in)	Ht. (in)	Wd. (in)	Ln. (in)	Th. (in)	Ht. (in)	Wd. (in)	
CL0400	400	181	6-3/4	7-1/4	7-3/4	16	2-1/2	6-1/2	4	3/8	2-7/8	3	21
CL1000	1000	453	6-3/4	7-1/4	10-3/4	16	2-1/2	6-1/2	7	3/8	2-7/8	3	33
CL1500	1500	680	6-3/4	7-1/4	14-3/4	16	2-1/2	6-1/2	10-1/2	3/8	2-7/8	3	46
CL2200	2200	998	7	10-1/2	15	16	2-1/2	9-3/4	11-1/4	3/8	2-7/8	3	69
CL3000	3000	1360	7	10-1/2	19-1/4	16	2-1/2	9-3/4	15-1/4	3/8	2-7/8	3	92

Working Load Limit (WLL) in lbs (kg) & *Maximum Sheet Length Due To Sag For Material Thickness For Single Magnet Use								
Model No.	3/16" (6' Length)	1/4" (6' Length)	3/8" (8' Length)	1/2" (8' Length)	3/4" (8' Length)	1" (10' Length)	3" (10' Length)	
CL0400	400 (181)	400 (181)	400 (181)	400 (181)	400 (181)	400 (181)	400 (181)	400 (181)
CL1000	600 (272)	900 (408)	1000 (453)	1000 (453)	1000 (453)	1000 (453)	1000 (453)	1000 (453)
CL1500	800 (362)	1000 (453)	1500 (680)	1500 (680)	1500 (680)	1500 (680)	1500 (680)	1500 (680)
CL2200	800 (362)	1064 (482)	1725 (782)	2000 (907)	2200 (998)	2200 (998)	2200 (998)	2200 (998)
CL3000	800 (362)	1100 (498)	1800 (816)	2700 (1224)	3000 (1360)	3000 (1360)	3000 (1360)	3000 (1360)

**NOTE:** Lifting Values for the Creative Lift® Magnets are stated at 33% of the actual value. We recommend when lifting sheets over 8', use 2 or more lifts on a spreader bar to prevent sheet flexing, sagging or peel-off. Thin material is susceptible to magnetic bleed through, resulting in two sheets being lifted at once. \*These maximum sheet lengths are selected due to the sag characteristics of the specified sheet. The item to be lifted must cover the entire length and width of the magnetic poles to properly engage and release the part.

# PERMANENT RARE EARTH MAGNETIC LIFTS



## PowerLift® Magnets

These compact switchable Rare Earth permanent lift magnets can be used on flat or round surfaces and contain an internal release On/Off device that does not contact or damage the surface of the part being lifted. Permanent magnetic lifts eliminate the fear of dropping the load being lifted due to power failures.

The locking system is performed by first pulling on the handle to release the lock pin, then rotating the handle to the desired position. The locking feature prevents the handle from being bumped partially "On" and avoids giving the operator a false feeling that the magnet is holding safely.

### Features

- On/Off Rare Earth Permanent Magnet
- Handle locks in both On and Off position
- Lifts flat or round loads (see chart below)
- Easy internal manual release does not contact the load
- RFID Enabled
- Heat resistant up to 180°F (82°C)
- 3:1 Design Factor
- ASME B30.20 BTH-1 Design Category B Service Class 3



Picture above: A customized version of IMI's Vertical Lift Adaptor featuring two PowerLift® magnets, designed to lift ferrous metal from horizontal to vertical orientation or vice versa. Adjustable for various widths, thicknesses and shapes. Ask for Tech Sheet MG-02G for specifications.

Model No.	WLL		Overall		Magnet			Handle		Bail		
	LBS	KG	Ht. (in)	Ln. (in)	Ht. (in)	Wd. (in)	Ln. (in)	Ln. (in)	Th. (in)	Ht. (in)	Wd. (in)	Wt. (lbs)
PNL0250	250	113	6-5/8	5	2-5/8	2-5/8	3-5/8	4	3/16	1-3/8	1-1/2	6
PNL0800	800	363	8-7/8	7-7/8	3-7/8	3-5/8	6-3/8	8	1/2	2-3/8	1-3/4	21
PNL1600	1600	726	8-7/8	10-3/4	4-3/4	4-7/8	9-1/8	9	5/8	3-1/2	2-1/4	51
PNL2500	2500	1134	8-7/8	12-5/8	6-1/2	7-1/8	10-5/8	10-3/4	3/4	4-3/4	3-3/4	122
PNL5000	5000	2268	18	16-1/2	8-3/8	9-1/4	14-7/8	16-3/4	7/8	6	4-3/4	288
PNL6600	6600	2993	22-1/4	20	10-1/4	11-1/4	18-1/16	20-5/8	1-7/16	7-1/4	5-3/4	485

Model No.	Working Load Limit (WLL) in lbs (kg) & *Max Sheet Length Due To Sag For Material Thickness For Single Magnet Use							Round Lifting Applications			
	1/4" (6' Lg)	3/8" (8' Lg)	1/2" (8' Lg)	3/4" (8' Lg)	1" (10' Lg)	2" (10' Lg)	3" (10' Lg)	Lift - lbs (kg)	Min. Dia. (in)	Min. Th. (in)	
PNL0250	180 (81)	250 (113)	250 (113)	250 (113)	250 (113)	250 (113)	250 (113)	125 (57)	2	1/2	
PNL0800	270 (122)	500 (226)	615 (279)	800 (362)	800 (363)	800 (363)	800 (362)	400 (181)	3	1/2	
PNL1600	NA	CF	800 (362)	1600 (726)	1600 (726)	1600 (726)	1600 (726)	800 (362)	4	1	
PNL2500	NA	NA	CF	NA	1490 (675)	2500 (1134)	2500 (1134)	1250 (567)	5	2	
PNL5000	NA	NA	NA	NA	NA	CF	2625 (1190)	5000 (2268)	2500 (1134)	14	4
PNL6600	NA	NA	NA	NA	NA	NA	6600 (2993)	3300 (1496)	CF	CF	

**NOTE:** Lifting Values for the PowerLift® Magnets are stated at 33% of the actual value. We recommend when lifting sheets over 8', use 2 or more lifts on a spreader bar to prevent sheet flexing, sagging or peel-off. Thin material is susceptible to magnetic bleed through, resulting in two sheets being lifted at once. Round Item Lifting Values are based on ideal conditions. Pipe length, wall thickness, diameter and surface condition can all affect the magnet's performance. Please consult the factory before specifying these magnets for use on round materials. \*These maximum sheet lengths are selected due to the sag characteristics of the specified sheet. The item to be lifted must cover the entire length and width of the magnetic poles to properly engage and release the part. CF = Consult Factory NA = Not Applicable (Magnets listed will not turn "ON" on specified material thicknesses.)

# PERMANENT RARE EARTH MAGNETIC LIFTS



## VersaLift™ Magnets

Compact switchable Rare Earth permanent lift magnet for use on flat or round surfaces. Contains an internal On/Off release device that does not contact or damage the surface of the part. Locking On/Off handle prevents the handle from being bumped “On” or “Off”, combined with a permanent magnetic lift, eliminates the fear of dropping the load. More features than other lifts and manufactured in the USA (USA M.A.D.E.™).

### Features

- Rare Earth Permanent Magnet
- Vertical Lift Capable using the optional Lift Lug attachment
- RFID Enabled - Embedded RFID Chip
- Locking On/Off handle & Test load feature
- Supports custom pole shoes (4, 1/4”-20 Tapped Holes, 1/2” deep)
- Lifts flat or round loads (see chart below)
- Stationary Lift Lug(s)
- Heat resistant up to 180°F (82°C)
- 3:1 Design Factor
- ASME B30.20 BTH-1 Design Category B Service Class 3



To operate Test Feature, pull spring loaded handle out and rotate it to the “TEST” position. Lift load approximately 2-3” to verify the magnet has the capacity to lift your load. Once verified, place load back down and turn the handle to the “ON” position. **Never complete entire lift operation in “TEST” position.**

Model No.	WLL		Overall		Magnet			Handle		Bail		
	LBS	KG	Ht. (in)	Ln. (in)	Ht. (in)	Wd. (in)	Ln. (in)	Ln. (in)	Th. (in)	Ht. (in)	Wd. (in)	Wt. (lbs)
VL0600	600	272	6-1/2	7	3-3/4	5	5-5/8	6	3/4	2-1/4	1-3/4	20
VL0600W/LUG	600	272	6-1/2	11-5/16	3-3/4	5	5-5/8	6	3/4	2-1/4	1-3/4	21.15
VL1200	1200	544	6-1/2	11	3-3/4	5	10	6	3/4	2-1/4	1-3/4	27
VL1200W/LUG	1200	544	6-1/2	15-5/16	3-3/4	5	10	6	3/4	2-1/4	1-3/4	28.15
VLLUG1	-	-	3-1/2	4-5/16	-	-	-	-	-	-	-	1.15

Horizontal Part Working Load Limit in lbs (kg) & *Maximum Sheet Length Due To Sag For Material Thickness For Single Magnet Use								
Model No.	1/4" (6' Length)	3/8" (8' Length)	1/2" (8' Length)	3/4" (8' Length)	1" (10' Length)	2" (10' Length)	3" (10' Length)	
VL0600	260 (117)	435 (197)	525 (238)	550 (249)	600 (272)	600 (272)	600 (272)	
VL1200	NA	755 (342)	960 (435)	1165 (528)	1200 (544)	1200 (544)	1200 (544)	

Model No.	Horizontal Part Round Lifting Applications			Vertical Part Lift (Flat Only)	
	Maximum WLL - lbs (kg)	Maximum WLL at Minimum	Diameter / Thickness	WLL - lbs (kg)	Minimum Thickness
VL0600	300 (136)	130 (58)	2.00 In. / 0.12 In.	150 (68)	1.00 In.
VL1200	600 (272)	600 (272)	4.00 In. / 0.50 In.	300 (136)	1.00 In.

**NOTE:** Lifting Values for the VersaLift™ Magnets are stated at 33% of the actual value. We recommend when lifting sheets over 8', use 2 or more lifts on a spreader bar to prevent sheet flexing, sagging or peel-off. Thin material is susceptible to magnetic bleed through, resulting in two sheets being lifted at once. Round Lifting Values are based on ideal conditions. Consult the factory before specifying these magnets for use on round materials. \*Max. sheet lengths are selected due to sag characteristics of specified sheet. The item to be lifted must cover the entire length and width of the magnetic poles to properly engage and release the part. **NA = Not Applicable (Magnets will not turn “ON” with stated thicknesses.)**

## DynamicLift™ Magnets

These lightweight switchable Rare Earth permanent lift magnets can be used on flat or round surfaces and contain an internal release On/Off device.

### Features

- Top rotating On/Off actuated Rare Earth permanent magnet
- Lifts flat or round loads horizontally and flat loads vertically
- Locking On/Off handle
- Heat resistant up to 180°F (82°C)
- 3:1 Design Factor
- ASME B30.20 BTH-1 Design Category B Service Class 3



Model No.	Working Load Limit (WLL)		Overall		Magnet			Handle		Bail		
	LBS	KG	Ht. (in)	Ln. (in)	Ht. (in)	Wd. (in)	Ln. (in)	Ln. (in)	Th. (in)	Ht. (in)	Wd. (in)	Wt. (lbs)
DL0150	150	68.04	9	5	2-3/4	2-1/2	3	2-1/2	1/4	2-1/4	3	6.1
DL0334	334	151.50	9-1/4	6-1/2	3	4	4-1/4	2-1/2	1/4	2-1/4	4	13.3

Horizontal Flat Part WLL (lbs (kg)), Min. Steel Thickness & *Max. Length Due To Sag For Single Magnet								Vertical Part Lift (Flat Only)	
Model No.	1/4" (6' Lg.)	3/8" (8' Lg.)	1/2" (8' Lg.)	3/4" (8' Lg.)	1" (10' Lg.)	2" (10' Lg.)	3" (10' Lg.)	WLL - lbs (kg)	Min. Thickness
DL0150	150 (68.04)	150 (68.04)	150 (68.04)	150 (68.04)	150 (68.04)	150 (68.04)	150 (68.04)	40 (17.01)	0.25 In.
DL0334	275 (124.73)	320 (145.15)	334(151.49)	334(151.49)	334(151.49)	334(151.49)	334(151.49)	75 (37.88)	0.37 In.

Horizontal Round Part Round Lifting Applications					
Model No.	Maximum WLL - lbs (kg)	Minimum Diameter	Minimum Wall Thickness	Maximum WLL at Min. Diameter & Min. Thickness	
DL0150	75 (34.02)	2	1/8	65 (29.48)	
DL0334	167 (75.75)	4	1/8	100 (45.36)	

**NOTE:** Lifting Values for the DynamicLift™ Magnets are stated at 33% of the actual value. We recommend when lifting sheets over 8', use 2 or more lifts on a spreader bar to prevent sheet flexing, sagging or peel-off. Thin material is susceptible to magnetic bleed through, resulting in two sheets being lifted at once. Consult the factory before specifying these magnets for use on round materials. Round Item Lifting Values are based on ideal conditions. Length, wall thickness, diameter and surface can all affect the magnet's performance. \*Maximum sheet lengths are selected due to the sag characteristics of the specified sheet. The item to be lifted must cover the entire length and width of the magnetic poles to properly engage and release.

## Remote Operated DynamicLift™ Magnet

The remote operated DynamicLift™, featuring Magswitch® technology, is a powerful Rare Earth permanent lift magnet that can be turned “On” or “Off” using a remote control without the need of air or electricity! Not only does this give the operator freedom from electrical cords and air hoses, but also opens up a whole new range of lifting possibilities where accessibility to the magnet was cumbersome or impossible to reach, such as lifting above or below arm’s length, into deep channels, loading or unloading CNC/cutting tables and operation from inside the forklift. Permanent magnetic lifts also eliminate the fear of dropping the load being lifted due to power failures.

### Features

- Remote Operated, locking, On/Off Rare Earth permanent magnet
- Will stay “on” if battery loses power
- Secondary manual release in case of battery failure
- Indicator lights for magnet operational state and battery strength
- Built in safety - a load sensor and a 3-button off sequence prevent accidental release while under load
- Includes two, 12 volt rechargeable, Lithium-ion batteries (200 cycles per charge) and charger
- Heat resistant up to 180°F (82°C)
- 3:1 Design Factor
- **ASME B30.20 BTH-1 Design Category B Service Class 3**



Model No.	Lift		Overall				Magnet			Bail		
	LBS	KG	Ht. (in)	Wd. (in)	Ln. (in)	Ht. (in)	Wd. (in)	Ln. (in)	Th. (in)	Ht. (in)	Wd. (in)	Wt. (lbs)
DLR0600	600	272	12-1/2	4	8-1/2	4	2-3/4	6-1/2	3/8	2-1/2	3-1/4	20

### Working Load Limit in lbs (kg) & \*Maximum Sheet Length Due To Sag For Material Thickness For Single Magnet Use

Model No.	1/4" (6' Lg)	3/8" (8' Lg)	1/2" (8' Lg)	3/4" (8' Lg)	1" (10' Lg)	2" (10' Lg)	3" (10' Lg)
DLR0600	368 (166)	475 (215)	550 (249)	575 (260)	600 (272)	600 (272)	600 (272)

**NOTE:** Lifting Values for the DynamicLift™ Magnets are stated at 33% of the actual value. We recommend when lifting sheets over 8', use 2 or more lifts on a spreader bar to prevent sheet flexing, sagging or peel-off. Thin material is susceptible to magnetic bleed through, resulting in two sheets being lifted at once. Please consult the factory before specifying these magnets for use on round materials. \*These maximum sheet lengths are selected due to the sag characteristics of the specified sheet. The item to be lifted must cover the entire length and width of the magnetic poles to properly engage and release the part.

## Automatic Lifting Magnet

Innovative, compact and user-friendly, this magnetic lifting equipment features a strong permanent magnet that is switched between the “on” and “off” states with an electrical pulse.

This permanent lift magnet uses an electronic impulse ONLY to change the magnet from on to off and vice-versa. No electrical power is used during the lifting process. The result of this technology is safe and reliable lifting and long & efficient operation without interruption - over one thousand lifts with one complete, 2 hour battery charge!

The real beauty of this magnet is that it is fully automatic - no user interface is required to turn the magnet on or off. The secret lies in the built-in load-sensing system. This unique feature utilizes a self-adjusting shaft that turns the magnet on or off every time it completes a cycle. When the magnet is set down on a load, the shaft goes down, which engages the magnet. The magnet stays “on” until the load is set back down, whereby the shaft goes down and turns the magnet “off”. The operator also has the option to manually control the magnet by pressing the push buttons located on the side of the unit.

### Features

- Rare Earth Permanent magnet
- Automatic controlled ON/OFF
- Operating Temp: 32°F to 122°F
- Internal chargeable battery for switching
- Fast cycle times
- Over one thousand lifts with one complete battery charge
- 3:1 design factor

**Automatic Lifting Magnet  
LI-120ALM**



Model No.	Lift		Overall				Bail		
	LBS	KG	Ht. (in)	Wd. (in)	Ln. (in)	Th. (in)	Ht. (in)	Wd. (in)	Wt. (lbs)
LI-120ALM	265	120	7.87	4.92	4.92	3/8	1-1/4	1-1/4	14.3

### Working Load Limit in lbs (kg) & \*Max Sheet Length Due To Sag

Model No.	3/16" (6' Lg)	1/4" (6' Lg)	3/8" (8' Lg)	1/2" (8' Lg)	1" (10' Lg)	3" (10' Lg)
LI-120ALM	78 (35)	111 (50)	232 (105)	265 (120)	265 (120)	265 (120)

**NOTE:** Lifting Values for the Ixtur® Automatic Lift Magnet are stated at 33% of the actual value. We recommend when lifting sheets over 8', use 2 or more lifts on a spreader bar to prevent sheet flexing, sagging or peel-off. Thin material is susceptible to magnetic bleed through, resulting in two sheets being lifted at once. \*These maximum sheet lengths are selected due to the sag characteristics of the specified sheet. The item to be lifted must cover the entire length and width of the magnetic poles to properly engage and release the part.

# LIFT MAGNET ACCESSORIES



## Round Electromagnet Lifts



Round Electro Lift Magnets (RELM) provide concentrated holding power and a deep reaching magnetic field to lift thick, non-flexing, ferrous items. 100% Duty Cycle

### Features

- No separate power supply required
- Control switch “On, Off and Release” functions
- Lower wattage requirements, higher lifting capacities and a lower unit weight than competitors
- 3’ long heavy-duty cord w/ plug



**NOTE:** RELMs are not intended to be used as scrap handling magnets. Picking up several pieces of steel at once is not recommended and may result in serious injury or property damage.

Model No.	WLL	Voltage (VAC)	Watts	Amps	Magnet Dia. (A)	Magnet Height (B)	Overall Height (C)	Bail Ht.	Bail Wd.	Weight (lbs.)
RELM06	1,000	120	85	0.8	6"	3"	6"	1-5/16"	1-5/16"	30
RELM08	2,000	120	130	1.1	8"	4-1/8"	7-3/8"	1-5/16"	1-5/16"	58
RELM10	3,000	120	170	1.5	10"	4-3/8"	8-3/8"	1-5/16"	1-5/16"	86
RELM12	4,500	120	200	2.0	12"	5-1/4"	9-1/4"	1-3/4"	1-3/4"	152
RELM16	8,000	120	310	3.0	16"	6-3/4"	12-3/4"	6"	3-1/2"	365
RELM20	12,000	120	570	5.0	20"	7-1/2"	14"	7"	4"	545

\*RELM WLL Values are stated at 50% of Breakaway Value. Design Factor 2:1.

## Battery Lifts

Battery Lift Magnets (BLM) operate from a self-contained automotive type battery (not included), which results in maximum convenience, portability, versatility, and dependability. BLMs make loading and unloading of thick non-flexing ferrous parts simple and fast. No need for external power cords. Ideal for remote locations. Built-in chargers and a visible power gauge. No fancy lights, whistles or bells that can malfunction.



**NOTE:** BLMs are not intended to be used as scrap handling magnets. Picking up several pieces of steel at once is not recommended and may result in serious injury or property damage.

## WeighPlus™ Crane Scale

The WeighPlus™ crane scale is a programmable, computerized, self-contained, and battery-operated crane scale with overload warning. The scale housing is made of durable stainless steel. All electronics are shock mounted and the recessed display and control area provides additional protection.

### Features

- Capacities of 5,000 lbs. and 15,000 lbs.
- Accurate to ±0.2% (0.002)
- Programmable Working Load Limit (WLL)
- Alarm function
- Power save mode
- Shock mounted electronics
- Uses 4 D-cell batteries, included
- LCD screen, multi colored
- Large top lift loop for easy crane use
- Zero Function. “Load Tare”. Can zero out weight of lifting device (magnet, chain, sling, etc.)
- Light weight design
- USA M.A.D.E.™



Model No.	Working Load Limit (lbs)	Overall Height (in)	Overall Width (in)	Overall Length (in)	Bail Thickness (in)	Bail Opening Height (in)	Bail Opening Width (in)	Clevis Opening (in)	Weight (lbs)
WPS05	5000	12.77	7.70	6.50	1.00	3.50	2.00	1.42	8
WPS15	15,000	12.77	7.70	6.50	1.00	3.50	2.00	1.42	8

## Load Control Magnet



Stay safe. This extremely powerful On/Off Permanent Rare Earth magnet lets you guide loads into position without being in close proximity. Attach On/Off permanent magnet to a corner or along the side of your load. As the load is lifted, the Load Control Magnet’s articulating connection to the lightweight telescoping pole allows you to control and position the load exactly where you want without endangering yourself, others or expensive equipment, should your lifting device fail.

### Features

- Powerful On/Off Rare Earth Magnet
- Works on Flat and Pipe
- Pole telescopes from 6’ to 12’
- Buy the magnet separately, use your own pole

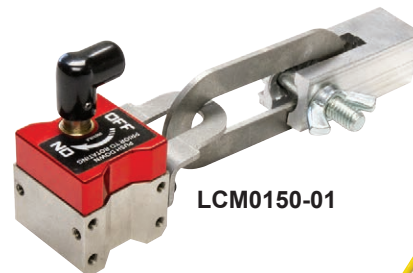

LCM0150-01



LCM0150-02

Hold - lbs (kg)	Pole Included	Ln. (in)	Ext. (in)	Wt. (lbs)	Model No.
150 (68.04)	No	7	N/A	1.20	LCM0150-01
150 (68.04)	Yes	80	147	2.70	LCM0150-02

Note: Magnet connector accepts a standard paint roller handle extension thread.

# LIFT MAGNET ACCESSORIES



## ■ Spreader Beams

When lifting large steel shapes, such as off-center loads, round, rectangular or long items (I-beams), one lift magnet may not be enough. IMI's Spreader Beams allow two magnets to be used at one time with only one lifting source. Magnets on a Spreader Beam keep your product level, reducing the height required to lift the load, providing a safer lift environment while reducing the time needed to move the load.

### SBI Series Features

- Low cost spreader beams
- One-piece construction
- Fork lift pockets
- Multiple spreads plus center hole



### SBC Series Features

- Beams 3' to 4' have 2 spreads
- Beams 6' to 10' have 3 spreads
- Swivel hooks with latches
- Designed and manufactured to ASME B30.20



### SBF-1/2-2 Series Features

- Ideal for Forklifts
- One-piece Construction
- Safety restraint secures beam to the forklift
- Weight: 9.5 lbs

Request Tech Sheet MG-02F

## ■ Weld-On Padeyes

Engineered and certified to meet all ASME BTH-1 categories and classes. Eliminate the need and time to engineer, fabricate, machine and certify lifting padeyes. By purchasing these one-of-a-kind padeyes, you can have them on the shelf ready to weld and speed up delivery, testing and approval of your projects.

### Features

- Hole is reamed to fit shackle pin/bolt  $\pm 0.01"$
- Weldable A36 Carbon Steel or 316 Stainless Steel
- Weld Spec and Weld Line on Padeye
- Date Coded
- Engineered and Certified

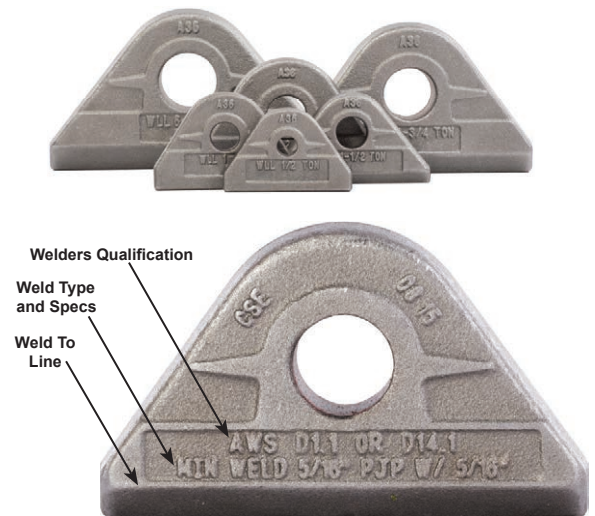
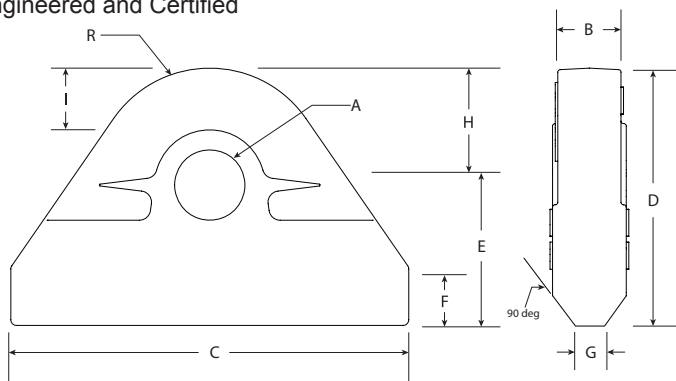

Request Tech Sheet MG-08A

Carbon Model No.	Stainless Model No.	Shackle Size	WLL (t)	A	B	C	D	E	F	G	H	I	R	Wt. (lbs)	Min. Weld
PE0050	PE0050S	1/4	1/2	21/64	11/32	2-7/64	1-3/8	3/4	5/16	N/A	5/8	7/16	5/8	0.20	0.188"
PE0100	PE0100S	3/8	1	15/32	9/16	2-7/16	1-5/8	7/8	3/8	N/A	3/4	1/2	3/4	0.40	1/4"
PE0150	PE1050S	7/16	1-1/2	17/32	5/8	2-3/4	1-9/16	7/8	1/4	7/32	11/16	13/32	11/16	0.40	3/16 PJP with 3/16" Fillet
PE0200	PE0200S	1/2	2	43/64	11/16	3-1/4	2-1/8	1-1/8	7/16	5/32	1	21/32	1	0.80	1/4 PJP with 1/4" Fillet
PE0475	PE0475S	3/4	4-3/4	15/16	1-1/8	4-7/16	2-5/8	1-7/16	1/2	15/32	1-1/4	25/32	1-1/4	2.20	5/16 PJP with 5/16" Fillet
PE0650	PE0650S	7/8	6-1/2	1-1/16	1-5/16	5-3/16	2-15/16	1-5/8	1/2	3/8	1-5/16	25/32	1-5/16	3.05	7/16 PJP with 7/16" Fillet

WLL = Working Load Limit

# MANHOLE COVER LIFT PRODUCTS



## Manhole Cover Lift Dolly System, Manhole Cover Lift System

Easily move heavy manhole covers up to 400 lbs. without worrying about your fingers, toes and back. This cover lift system uses a unique adjustable four-position hook with a four-length retractable handle for terrific leverage, even in tight spots. The three angle positions (90°, 105° and 120°) let you adjust the system for any lifting situation. The safety latch hook makes grabbing the magnet or spreader bar a one-person job.

*It doesn't matter if you are 5'6" or 6'5", the MCL Dolly can be adjusted to ergonomically accommodate any user.*

Choose from steel or aluminum manhole dollies. Dollies include your choice of heavy-duty 6", 10" or 12" Dia wheels. The dolly folds up and handle breaks down for easy storage. When fully extended, the handle length is 64"; when folded and collapsed down it is 41" long.

- Reduce lost time injuries caused by handling covers
- Minimize stress & strain on your body—system does the heavy work for you
- Retractable four-length handle gives maximum leverage from any angle
- Ideal for survey crews, handle breaks down for easy storage & transportation
- Makes moving covers fast, easy and a one-person operation

### Several magnet and hook configurations are available for use with your dolly

Use each dolly with either a single magnet in the center of the manhole cover, or with two magnets and a spreader bar (magnets and spreader bar sold separately). When using two magnets on a spreader bar, the load is more balanced—ideal for large covers or heavily textured surfaces. The spreader bar has three location holes so you can place the magnets where you gain the best magnet-to-steel-ratio. A sample of common On/Off Locking Rare Earth magnet choices are listed in the table below. Contact us to for more information on other magnet options.

The optional cover lift Dolly Extension Hook lets you lift very large diameter manhole covers that might otherwise interfere with proper dolly operation. Use on covers up to 54" for 6" wheeled dollies, 50" for 10" wheeled dollies or 48" for 12" wheeled dollies.



**THE ORIGINAL**  
 PATENT # US 7,503,743  
 & US 7,544,035  
 Most Ergonomic Dolly System on the Market!

### Manhole Cover Lift Spreader Bar Specifications

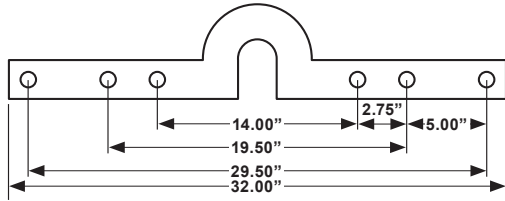

COVER SAMPLES AND RECOMMENDATIONS	
<b>DOLLY WITH SINGLE MAGNET</b>	
	Textured - all high points on same plane
<b>DOLLY WITH TWO MAGNETS ON A SPREADER BAR</b>	
	Center Raised - Manhole Cover Cross Section
	Low Center - Manhole Cover Cross Section



Manhole Cover up to 26" dia. - Magnet & Dolly Combo		
Part No.	Description	Weight (lbs)
MCL2W06PNL0800	Steel Dolly with 6" Wheels and PowerLift Magnet	46 + 21
MCL2W12PNL0800	Steel Dolly with 12" Wheels and PowerLift Magnet	52 + 21
MCL3W06VL0600	Aluminum Dolly with 6" Wheels and VersaLift Magnet	29 + 20
MCL3W12VL0600	Aluminum Dolly with 12" Wheels and VersaLift Magnet	34 + 20
30"-35" dia. Manhole Covers & Trench Grates - Magnet & Dolly Combo		
MCL2W06PNL1600	Steel Dolly with 6" Wheels and PowerLift Magnet	46 + 51
MCL2W12PNL1600	Steel Dolly with 12" Wheels and PowerLift Magnet	52 + 51
MCL3W06VL1200	Aluminum Dolly with 6" Wheels and VersaLift Magnet	29 + 37
MCL3W12VL1200	Aluminum Dolly with 12" Wheels and VersaLift Magnet	34 + 37
For 36" and greater dia. Manhole Covers or Grates, Vented Lids, Heavily Textured Surfaces a Dolly, plus a Spreader Bar with (2) magnets from menu below, i.e. MCL200W06 + MCL660X2 Dollies Only		
MCL2000W06	Dolly, Steel, 6" Wheels	46
MCL2000W10	Dolly, Steel, 10" Wheels	52
MCL2000W12	Dolly, Steel, 12" All-Terrain Wheels	52
MCL3000W06	Dolly, Aluminum, 6" Wheels	29
MCL3000W10	Dolly, Aluminum, 10" Wheels	34
MCL3000W12	Dolly, Aluminum, 12" All-Terrain Wheels	34
Magnet Options		
MCL660X2	Spreader Bar with (2) PNL0800 Magnets	49
MCL600X2	Spreader Bar with (2) Premium VL0600 Magnets	47
PNL0800	Powerlift® Magnet only, 800 lbs Rating	21
PNL1600	Powerlift® Magnet only, 1600 lbs Rating	51
VL0600	VersaLift™ Premium Lightweight Rare Earth Lift Magnet, 600 lb Rating	20
VL1200	VersaLift™ Premium Lightweight Rare Earth Lift Magnet, 1200 lb Rating	37
Accessories		
MCLWC18X16	Wheel Chocks 18" x 16"	17.5
MCLHOOKEXT	Dolly Hook Extension for Manhole Covers up to 48"	3
MCLLEGM	Septic Lid Lift Adapter with Manual Winch	28
MCLCHAIN	Double Leg Chain Extension for Septic Tank Lids	2.5

# MANHOLE COVER LIFT PRODUCTS



## PowerArm™ - Vehicle Mounted

The Manhole PowerArm™ makes lifting and replacing manhole covers easier than ever. Just drive within 3 feet of the center of the manhole cover and let the Manhole PowerArm™ adjust to your location. The “Arm” has a 3 foot, 180° swing radius that allows the positioning of the magnet to the center of the manhole cover.

The deep reaching strength of our Rare Earth magnet (sold separately) penetrates textured surfaces often found on manhole covers. Once the magnet is centered, turn the magnet to the “lock-on” position and use the winch (electric or manual versions available) to start lifting the manhole cover. When the manhole cover is clear from its rim, swing the manhole cover away. Reverse the steps to replace the manhole cover.

The PowerArm™ Winch can also allow the operator to lower items such as camera tractors, large sewer nozzles, pipe plugs and more.

### COMMON SPECIFICATIONS:

- 400 Lb. Lifting capacity
- Fits into standard 2” square receiver hitch
- Welded 2” x 3” tubular steel construction

### ELECTRIC WINCH SPECIFICATIONS:

- 12 VDC with power-up & power-down control, removable 15’ remote control cord and a galvanized cable with latch hook
- 7 Blade (SAE Standard) trailer and connector. Note: Vehicle must have the 12V Auxiliary/Trailer Battery Charge circuit properly installed and functional.

### MANUAL WINCH SPECIFICATIONS:

- Worm Gear winch that will hold load when handle is released
- Fine adjustment load movement
- Polyester strap with Zinc-plated hook & safety latch



Pictured Right:  
Optional Front Bumper  
Adaptor (MCLBA12) for  
C-Channel bumpers

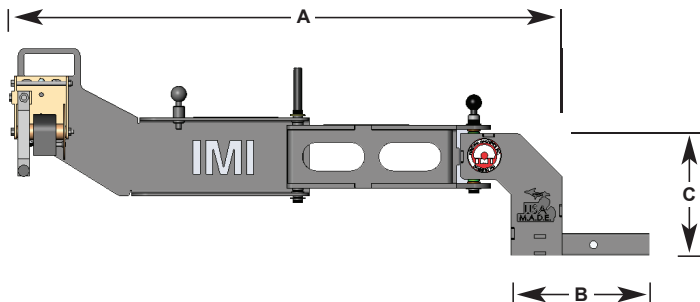

Winch Type	A (in)	B (in)	C (in)	Wt. (lbs)	Model No.
Electric	48	12.25	11.5	102	MCLPAE2000
Manual	48	12.25	11.5	79	MCLPAM2000



## ON/OFF Magnetic Utility Lifter

Stop bending over to lift and remove cast iron utility and valve box covers!

Reduce finger and toe injuries with this lightweight deep reach switchable permanent magnetic lifter. The magnetic field penetrates textured surfaces of lids and allows the operator to ergonomically lift the casting out of the way.

This Magnetic Utility Lifter has a locking On/Off handle for safety and makes removing covers quick and easy.



Lift - lbs (kg)	Height (in)	Width (in)	Length (in)	Wt. (lbs)	Model No.
50.0 (22.68)	28-1/2	5-1/2	3-1/2	7.65	MCLVB01
75.0 (34.02)	28-1/2	7	5	15.10	MCLVB02

# ELECTROMAGNETS & COUNTER WHEELS



## Electromagnets and Power Supply

Electromagnets offer On/Off capability through the application of controlled DC electrical current, controlled holding power and on-command release of ferrous steel parts. Most electromagnets require specially designed power supplies to achieve optimum magnetic performance. IMI offers power supplies for all of your electromagnet applications. Continuous duty 158°F (70°C) to 192°F (89°C) temperature rise. All electromagnets are **100% Duty Cycle**.

**Parallel Pole Electromagnets:** Ideal for Pick and Place or Lifting Applications where parts have flat surfaces and can be custom machined to specifically fit the application. Side mounted terminal blocks allow one set of lead wires from magnet to power supply (no splicing required, minimum 18 gauge leads). These electromagnets offer broad application potential due to their ability to deliver improved reach out through air gaps (i.e. painted, plated & coated surfaces).

**Rectangular & Round Island Pole Electromagnets:** Ideal for Pick and Place or Lifting applications where parts have uneven surfaces or odd shapes and provide concentrated holding power & high responsiveness in manual or automatic applications.

**Power Supply:** Designed for manual operation. Uses 120VAC input, 16 to 26VDC variable dual output, 10-foot grounded power cord and fuse protection. Temp. range -4°F to 160°F (-20°C - 71°C). Power supplies with automatic reverse pulse upon release are available.

### Rectangular Island Pole Electromagnets

WLL - lbs (kg)	Ht. (in)	Wd. (in)	Ln. (in)	Tap Size	No. of Holes	Spacing (in)	Watts	Wt. (lbs)	24 VDC	120 VAC
50 (22.68)	1-1/4	1-1/2	1-1/2	10-32	1	Centered	8.0	0.31	ES2-111	-
80 (36.29)	1-1/4	1-1/2	2-1/2	10-32	2	1	10.0	1.00	ES2-121	ESA-121
150 (68.04)	1-1/2	2-1/2	2-1/2	1/4-20	1	Centered	14.0	2.00	ES2-221	ESA-221
300 (136.08)	1-7/8	2-1/2	4-1/2	1/4-20	2	2	29.0	5.00	ES2-241	ESA-241
850 (385.55)	2-1/2	4	8	3/8-16	2	4	58.0	18.00	ES2-482	-

### Round Island Pole Electromagnets

WLL - lbs (kg)	Dia. (in)	Ln. (in)	Tap Size	Watts	Wt. (lbs)	24 VDC	120 VAC
5 (2.27)	3/4	1-1/4	10-32	1.4	0.2	ER2-071	-
7 (3.18)	1	3/4	10-32	1.5	0.2	ER2-101	-
12 (5.44)	1	1-1/4	10-32	3.6	0.3	ER2-102	-
25 (11.34)	1-1/4	1-1/4	1/4-20	4.4	0.4	ER2-103	-
40 (18.14)	1-1/2	1-1/2	1/4-20	4.6	0.7	ER2-104	-
90 (40.82)	2	1-5/8	1/4-20	5.6	1.2	ER2-201	ERA-201
100 (45.36)	2	2-1/2	1/4-20	13.0	2.0	ER2-202	ERA-202
200 (90.72)	3	3	5/16-18	25.0	5.0	ER2-303	ERA-303
350 (158.76)	4	3	3/8-16	36.0	9.0	ER2-403	-

### Parallel Pole Electromagnets

WLL - lbs (kg)	Ht. (in)	Wd. (in)	Ln. (in)	Tap Size	Holes	Spacing (in)	Watts	Wt. (lbs)	24 VDC
55 (24.95)	1-3/8	1	1	1/4-20	2	1	0.22	6	EP2-121
80 (36.29)	1-3/8	1	3	1/4-20	2	2	9	1.00	EP2-131
100 (45.36)	1-3/8	1	4	1/4-20	2	3	11	1.00	EP2-141
230 (104.33)	2-3/4	2	4	5/16-18	2	3	21	4.00	EP2-242
320 (140.62)	2-3/4	2	6	5/16-18	2	4.5	30	5.00	EP2-262
430 (195.04)	2-3/4	2	8	5/16-18	2	6.50	36	8.00	EP2-282

### Power Supply

Ht. (in)	Wd. (in)	Ln. (in)	Watts	Wt. (lbs)	Amps	Model No.
1-3/8	3-5/16	6-1/4	100	1.00	4.5	PSA1210SB

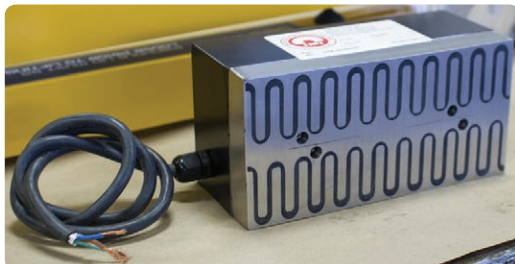

Rectangular Electromagnet with 120 VAC cord



Round Electromagnet

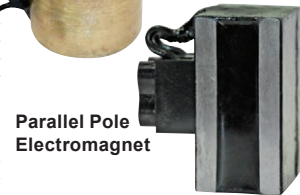

Parallel Pole Electromagnet



Power Supply

Custom Electromagnets are available.

## Magnetic Counter Wheels

Magnetic counter wheels can be used with a mechanical counter to measure the length of coiled steel and aluminum.\*\* allowing the operator to monitor shift or roll production, detect shortages or overages and record the amount of defective stock. Unlike rubber faced wheels, magnetic wheels do not tend to slip on oily stock. When used in aluminum applications, magnetic counters can run on the steel feed or pinch rolls.



Wheel dia. is 3.8197" ±0.0010" to measure one linear foot per revolution. The face width is 0.813" with a 0.5" long hub with a 1/4-20 set screw.

Part No	Description
5C926-3/8	Counter Wheel - 3/8" Bore
5C926-1/2	Counter Wheel - 1/2" Bore

## ON/OFF Magnetic Tie-Downs

Switchable Magnetic Tie-Downs for temporary or portable holding of tarps, signs, banners, etc. No need to drill, bolt or weld mounting tabs to steel surfaces. Place magnet on clean steel, push the handle slightly down and rotate 180° to turn magnet "On." Reverse steps to turn magnet "Off."

### Features

- On/Off Permanent Rare Earth Magnet
- Locking On/Off Handle
- Performs best when mounted on a clean, smooth, flat, metal surface that is at least 1/4" thick
- Works on flat and round ferrous surfaces
- 4:1 design factor



Hold lbs (kg)	Round lbs (kg)	Ht. (in)	Wd. (in)	Ln. (in)	Loop Dia. (in)	Wt. (lbs)	Model No.
35.0 (15.88)	19 (8.62)	2-3/4	1-13/16	4-1/8	1-1/8	0.90	MTD035R
110 (49.90)	57 (25.85)	4-3/4	2-3/4	5-3/4	1-1/8	4.50	MTD110R

# DEMAGNETIZERS



## Continuous Duty Surface Type Demagnetizers

Surface Type Demagnetizers are designed for stationary or portable use, providing continuous duty operation as work pieces pass the demagnetizer's face plate. This design allows for installation under, over or alongside conveyors for demagnetizing applications.

### Features

- Durable, one-piece face plate
- On/Off switch
- Portable and/or stationary design
- Integrated side handles for hand held operation
- AC On Indicator (DSC423 Only)

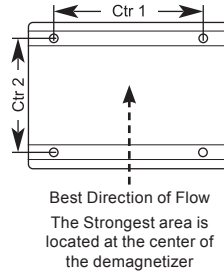
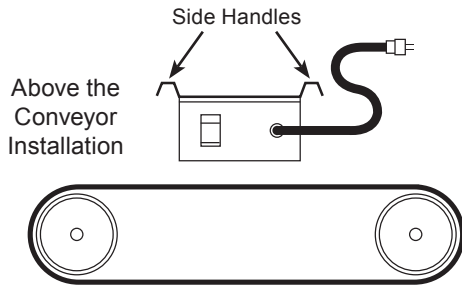

Note: 10 ft. cord with grounded plug on 120 VAC models only. 240 VAC models have a 6 ft. three wire cord without plug.

Ht. (in)	Wd. (in)	Ln. (in)	Demag Area (in)	Ctr. 1 (in)	Ctr. 2 (in)	Hole Dia. (in)	Wt. (lbs)	Amps (120 VAC)	Amps (240 VAC)	Amps (480 VAC)	Model No.
3-13/16	4-3/4	7-1/4	3 x 4.5	5-5/16	5-3/8	1/4	15.0	2.1	1.1	0.52	DSC423
4-15/16	6-1/4	11-1/4	4 x 6	7-13/16	6-7/8	5/16	33.0	9.0	5.0	2.50	DSC424

## Continuous Loop Type Demagnetizers



IMI's Loop Type Demagnetizers are designed with engineered efficiency and constructed to handle continuous applications. These units, designed with circular or rectangular pass through, can be selected for the shape and the material being processed to achieve maximum demagnetizing effectiveness. The standard pass through sizes range from 3" high x 6" wide to 18" high x 36" wide rectangular openings and a 2-7/8" diameter round opening size. We welcome requests for custom openings to meet your application. Most are available in 120, 240, and 480 VAC, single phase.



### Options

- Aluminum framed parts conveyor
- Mounting frames and stands

Overall			Opening Size		VAC			Wt. (lbs)	Model No.
Ht. (in)	Wd. (in)	Depth. (in)	Ht. (in)	Wd. (in)	120	240	480		100% Continuous
8	7	5-1/4	2-7/8 dia.	-	Y	-	-	15	DMC100
16	18	16	3	6	-	Y	Y	150	DMC200
17	18	16	4	6	-	Y	Y	160	DMC300
20	25	16	6	12	-	Y	Y	300	DMC400
24	32	16	9	18	-	Y	Y	450	DMC500
28	40	16	12	24	-	Y	Y	600	DMC600
36	54	16	18	36	-	Y	Y	900	DMC700



## Magnetizer/Demagnetizer

Keep those small screws and nuts in position. Insert a screwdriver or nut driver into the hole, pull it out and it's magnetized. Leave the magnetizer on the tool for extra strength. To demagnetize, pass the tool through one of the outside channels. Perfect for use with computers, magnetically sensitive equipment or anyone who uses a screwdriver.



Dimensions (in)	Thru-Hole	Wt. (lbs)	Model No.
1-1/8 cubed	3/8	0.15	M/D001

## Spark Plug Boot Pliers

Insulated spark plug boot pliers grip boot to prevent wire damage, electrical shock and burns.

### Features

- Pliers handle and jaws are coated with a 90 durometer heavy-duty plastic for a sure grip
- PLS140 is ideal for use against the fire wall and on minivans
- PLS100S contains one of each pair of pliers. Be ready for any difficult to reach boot.



Description	Jaw Ln. (in)	Jaw Wd. (in)	Ln. (in)	Wt. (lbs)	Model No.
5 Piece Set - Spark Plug Boot Pliers (1 of ea. model)	—	—	—	2.85	PLS100S
Spark Plug Boot Pliers - 45° Angle	3	1-1/8	9-3/4	0.50	PLS100
Spark Plug Boot Pliers - Straight	2-3/4	1-1/8	9-1/2	0.50	PLS110
Spark Plug Boot Pliers - Straight	4-1/4	1-7/8	11	0.60	PLS120
Spark Plug Boot Pliers - 45° Angle	4-1/4	1-7/8	11	0.60	PLS130
Spark Plug Boot Pliers - 90° Angle	4	2	10-1/4	0.65	PLS140
Nylon Spark Plug Boot Pliers - 20° Angle	2-1/4	5/8	7	0.10	PLS200N

## Push Pin Pliers



Quickly remove plastic push pin anchors with center locking pin without damage to pins, anchors, fasteners or retainers.

### Features

- Steel frames with spring return
- Black oxidized to resist rust
- Quick clean vinyl grip

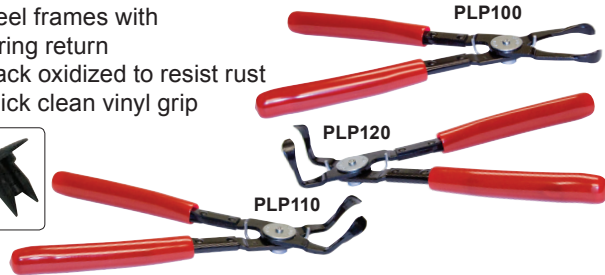

Description	Overall Ln. (in)	Wt. (lbs)	Model No.
3 Pc. set (1 of ea.)	—	1.35	PLP100S
Straight	9-3/4	0.45	PLP100
45° Angle	9-1/2	0.45	PLP110
90° Angle	9	0.45	PLP120

## Nylon Fuse Pullers and Installers



Remove and install hard to reach or difficult to pull fuses. Fully insulated, 100% non-conductive Nylon pliers, has ergonomic grip, and finger stops to protect fingers. PLF100 is used on Flat blade type fuses in Automotive, ATO and mini fuses. PLF200 is for 1/2" to 1" glass fuses in vintage automotive, appliance and industrial fuse application. Hook on end of grip pulls midjet fuses.

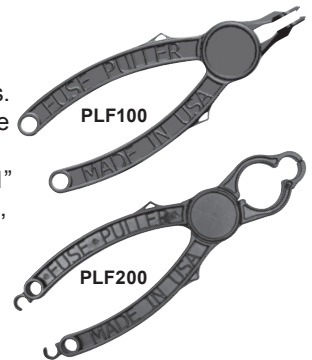

Description	Ln. (in)	Wt. (lbs)	Model No.
Flat Blade Fuse Puller/Installer	6	0.05	PLF100
Glass Fuse Puller/Installer	7-1/8	0.10	PLF200

## Hose Clamp Pliers



Swivel jaws are slotted for positive holding/removal of plastic and or metal constant tension hose clamps. Jaws rotate 360° to grip at any angle and can be locked in three holding positions, freeing up hands.

### Features

- Quick clean vinyl grip
- Finger tip locking pawl
- PLC200 is for use on Ford, GM, Chrysler, VW and other import vehicles for constant tension/Mobeas (flat band) clamps
- PLC210 is for use on vintage automotive and agricultural vehicles, appliances, irrigation/spraying systems, or Corbin (single wire) clamps
- PLC220 has universal tips, right or left facing clamp for constant tension Mobeas clamps

Description	Ln. (in)	Wt. (lbs)	Model No.
Automotive Hose Clamp - Straight	9	0.45	PLC200
Automotive/Agriculture/Appliance Hose Clamp - Straight	9	0.45	PLC210
Extra Large Automotive Hose Clamp - 45° Angle	10-1/2	0.55	PLC220
Extra Large Automotive Hose Clamp - Straight	10-1/2	0.55	PLC230





## Click Style Hose Clamp Pliers

Tired of breaking off reusable "click" style hose Clamps? These pliers have 360° swivel heads that provide access at any angle. Remove & install click clamps without destroying clamps! "Click" clamps are often found on power steering & other high pressure lines.

### Features

- Quick clean vinyl grip
- PLC100 has 2" jaws for small clips
- PLC110 has 4" jaws for larger or hard to reach clamps



"Click" Clamp

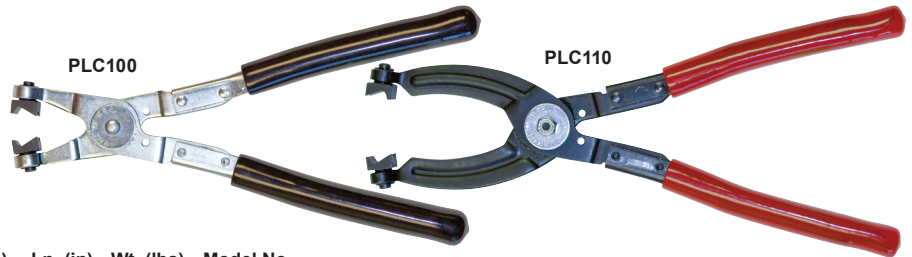

Description	Jaw Ln. (in)	Jaw Wd. (in)	Ln. (in)	Wt. (lbs)	Model No.
Click Pliers - Straight	2	1	9	0.45	PLC100
Click Pliers - Straight	3-1/2	1-3/4	10-1/2	0.45	PLC110

## Kant-Twist™ Cantilever Clamps



### Features

- Will not "walk-off-center"
- Eliminates distorting and twisting action of C-clamps
- Cantilever design provides 4:1 clamp ratio
- Three different gripping surfaces
- Built-in "V" block for round stock
- Free floating jaws adjust to uneven surfaces
- Copper plated jaws, screw and handle are ideal for welding
- Much lighter than C-Clamps. Great where weight is a factor
- Deep throat provides farther reach onto material
- Stainless steel clamps are ideal for use in corrosive, sanitary or magnetic application

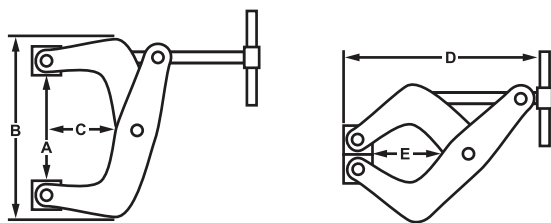
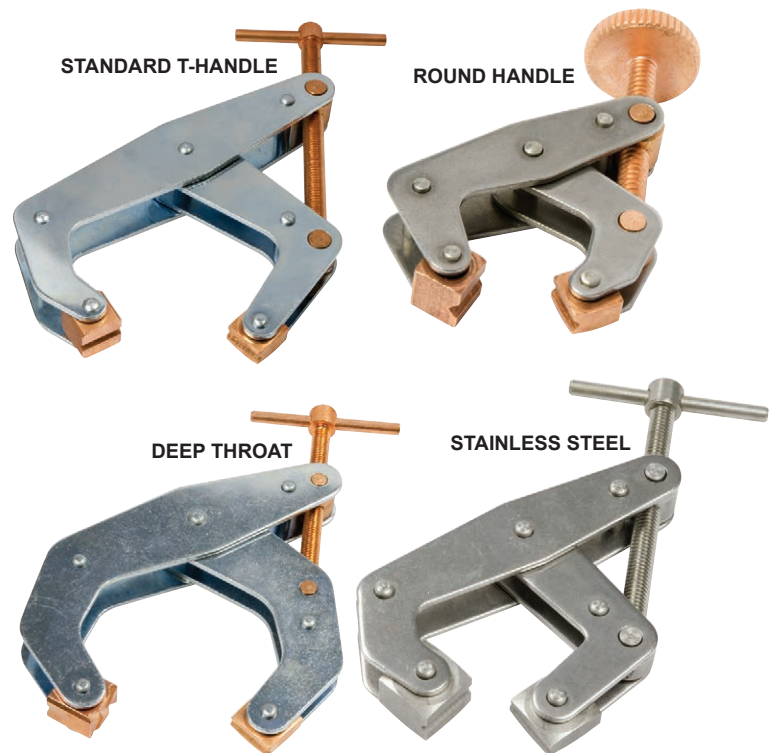

Max Jaw Capacity A (in)	Throat Depth Open B (in)	Open Width C (in)	Overall Length D (in)	Throat Depth Closed E (in)	Max Clamp Force (lbs)	Wt. (lbs)	Model No.
<b>T-Handle, Copper Plated Jaws, Screw and Handle</b>							
1	1/2	1-3/4	2-1/8	1/2	350	0.13	K010T
2	1-1/8	3-1/4	3-1/2	1-1/4	800	0.45	K020T
3	1-1/4	5	5-1/4	1-3/4	1500	1.25	K030T
6	3-1/8	8-1/4	6-1/4	3-3/8	2000	3.00	K060T
<b>Round Handle, Copper Plated Jaws, Screw and Handle</b>							
3/4	3/8	1-3/8	1-1/2	3/8	200	0.08	K007R
1	1/2	1-3/4	2-1/8	1/2	350	0.13	K010R
1-1/2	1-1/8	3	3	1	600	0.25	K015R
2	1-1/8	3-1/4	3-1/2	1-1/4	800	0.50	K020R
<b>T-Handle Deep Throat, Copper Plated Jaws, Screw and Handle</b>							
2-7/16	2	4-1/16	4-1/8	1-13/16	700	0.58	K025TD
4-1/2	2-1/4	6-3/4	7	3-13/16	1700	1.80	K045TD
6	4-1/2	10	11	5-1/2	2000	4.16	K060TD
<b>T-Handle 303 Stainless Steel Construction</b>							
2	1-1/8	3-1/4	3-1/2	1-1/4	700	0.45	K020TS
3	1-1/4	5	5-1/4	1-3/4	1200	1.25	K030TS
4-1/2	2-1/4	6-3/4	7	2-1/2	1500	1.80	K045TS

# FANNERS FOR SHEET SEPARATION



## ■ Permanent Magnetic Sheet Fanners

Permanent Magnetic Fanners handle steel sheets of almost any length, width or shape. The sheets near the top of the stack separate instantly from a 1/2" to 3/4" gap, depending on sheet thickness and size.

- Reduce costs and increase safety for destacking steel sheet stock
- A powerful magnetic field automatically separates sheets
- As the top sheet is removed, the next sheet instantly fans up
- Assists prying apart sticky, oily, pre-finished or polished sheets
- Eliminates die-damaging double blanking in automated operations
- Three powerful designs for optimum fanning performance
  - Thin Gauge Fanner (TNF), 20 to 30 Gauge
  - Medium Gauge Fanner (MGF), 12 to 22 Gauge
  - Thick Gauge Fanner (TKF), 7 to 12 Gauge
- Pre-tapped holes for mounting to your equipment
- Bolt on angle base plate and handle with mounting hardware included
- Durable welded construction

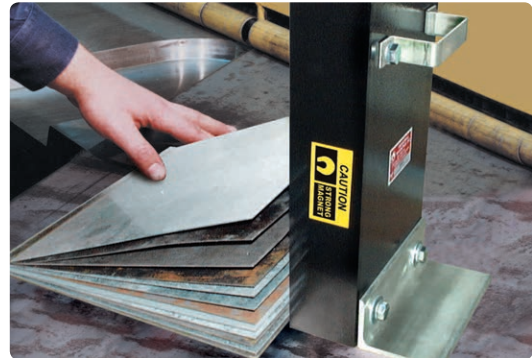

For more information on this product, contact us by phone, email or visit our website to request Tech Sheet AG-05A.

## ■ Sheet Seeker® - Ergonomic Permanent Magnetic Fanners



The SheetSeeker® (U.S. Patent: 6,845,976) is a breakthrough in magnetic sheet fanner technology. The magnetic circuit is lifted and locked into place for introduction to a stack of sheet steel. Once the stack is in place, the sliding magnet is unlocked and automatically centers on the top of the stack, fanning the sheet stock. As each sheet is lifted away, the magnet indexes down automatically, fanning to the bottom of the stack.

- Powerful, Rare Earth, automatic-indexing magnetic circuit
- Up to 60% lighter than standard sheet fanners with the same fanning strength
- Magnet automatically indexes down to ensure optimum fanning down to the last sheet
- Lightweight design and convenient top mounted carry handle allow for user-friendly transport
- Minimum height of 12" with custom designs and options available
- Fans from 30 gauge sheets to 3/16" plate
- Durable stainless steel construction
- Slide handle for positioning the fanning circuit
- Top locks for slide handle
- Break Away Bar
- Optional On/Off magnetic base for easy installation and removal

U.S. Patent No. 6,845,976



For more information on this product, contact us by phone, email or visit our website to request Tech Sheet AG-05A.

## ■ Electromagnetic Sheet Fanners



The On/Off capability of Electromagnetic Sheet Fanners provides operator safety during steel blank stacking and unbanding. In automated presses, the electromagnetic fanners can be controlled to operate simultaneously with other destacking equipment. Electromagnetic Sheet Fanners require special IMI power supplies that can provide for operation of single or multiple fanners. These power supplies (see Tech Sheet AG-10B) can be equipped with a variable output to adjust the magnetic strength to handle a variety of metal thicknesses.

- Reduce costs and increase safety for destacking steel sheet stock
- A powerful magnetic field automatically separates sheets
- As the top sheet is removed, the next sheet instantly fans up
- Assists prying apart sticky, oily, pre-finished or polished sheets
- Eliminates die-damaging double blanking in automated operations
- Safe and easy set-up with fanner turned off
- One size unit can handle a variety of metal thicknesses
- Ideal for automated presses



For more information on this product, contact us by phone, email or visit our website to request Tech Sheet AG-05A.

# FANNERS FOR SHEET SEPARATION



## Magnetic PinFanners™ - Permanent Magnetic Fanners

Use pallet mount Permanent Magnetic PinFanners™ with Hex, Round or T-Slot Pallet Pins in Stacking/Destacking, Blanking Lines and Press Feeding applications. PinFanners™ can be used to separate curved edge or odd shaped blanks. PinFanners™ stay right on the pallet, from the blanking line to the press, without any extra set up! Adjustable magnet positions ensure direct contact with the blank for maximum fanning ability. Mounted directly to the pallet, PinFanners™ reduce maintenance down time on blanking lines.

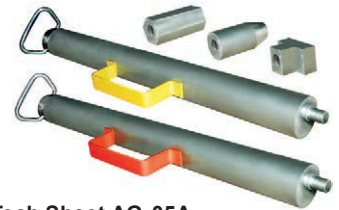

For more information on this product, contact us by phone, email or visit our website to request Tech Sheet AG-05A.

## Air Cylinder Fanners - Permanent Magnetic Fanners



Air Cylinder Actuated Sheet Fanners have an air release system that pulls the magnet inside away from the face of the fanner for easy and safe removal of the fanner from the stack.

- Reduce costs and increase safety for destacking steel sheet stock
- A powerful, Rare Earth magnetic field automatically separates sheets
- As the top sheet is removed, the next sheet instantly fans up
- Assists prying apart sticky, oily, pre-finished or polished sheets
- Eliminates die-damaging double blanking in automated operations
- On/Off of an electromagnet with the benefit of a permanent magnet
- Allows for mid stack change over

Permanent Magnetic Fanners handle steel sheets of almost any length, width or shape. The sheets near the top of the stack separate instantly from a 1/2" to 3/4" gap, depending on sheet thickness and size.



For more information on this product, contact us by phone, email or visit our website to request Tech Sheet AG-05B.

## Air Spring Fanners - Permanent Magnetic Fanners



Air Spring Fanners have an air spring system that pushes the magnet inside toward the face of the fanner when air pressure is present. When the air pressure is turned off or disconnected the air spring will deflate and the magnet will move away from the face of the fanner creating air gap that in essence turns the magnet off. This eliminates the risk of having metal accidentally attracted to the fanner during transportation or stack changeovers.

- Powerful, Rare Earth, magnetic circuit
- On/Off capability helps prevent injury when introducing new materials to the fanner
- "Fail-Safe" mode automatically returns the magnet to the "Off" position with loss of air pressure
- Fans from 30 gauge sheets to 3/16" plate
- Durable stainless steel welded cover construction



For more information on this product, contact us by phone, email or visit our website to request Tech Sheet AG-05B.

## Air Knife Fanners - Permanent Magnetic Fanners



Permanent Magnet Sheet Fanners with Air Knives allow for ferrous and non-ferrous sheets to be separated in destacking applications. While the magnet force will work with all ferrous metals, the air knives separate all non-ferrous metals by pushing air in between the sheets causing them to rise up from one another.

- Reduce costs and increase safety for destacking ferrous and non-ferrous sheets
- A magnetic field automatically separates ferrous sheets
- Powerful air knives automatically separate non-ferrous sheets
- As the top sheet is removed, the next sheet instantly fans up
- Assists prying apart sticky, oily, pre-finished or polished sheets
- Eliminates die-damaging double blanking in automated operations

Permanent Magnetic Fanners handle steel sheets of almost any length, width or shape. The sheets near the top of the stack separate instantly.



For more information on this product, contact us by phone, email or visit our website to request Tech Sheet AG-05B.



## ■ Transporter® - Cylinder Actuated (TPCA)

Transporter® Magnets are ideal for use where vacuum cups and grippers are typically used for lifting and moving steel sheets, blanks, stamped parts and complete assemblies.

### Applications & Benefits

- Automated press to press transfer systems
- Robotic “Pick & Place”
- Manual and automated machine loading/unloading
- Outlasts vacuum cups in most applications
- Grasps odd shaped or perforated parts
- Increases production and reduces shop air costs
- Designed for long, maintenance-free operation
- Operates effectively in any orientation
- Will not drop parts if system air-loss occurs
- Destacking (requires proper magnet selection)



### Cylinder Actuated Transporter® Magnets (TPCA)

The patented Transporter® utilizes a powerful, Rare Earth, Permanent Magnet to pick and place metal parts in automated transfer and manually operated material handling applications. Offering more options for pick-up points on stamped, forged and formed parts or complete parts assemblies. Offers increased material handling safety and a significant reduction over vacuum cups in shop air costs.

Ideal for steel lifting applications in the Automotive, Appliance and Office Furniture industries and available in many standard and custom configurations to best suit the needs of your application.

### Features

- Positively holds parts - no dropping
- Instantaneous pickup and release
- Permanent magnet requires no electricity

### Options

- Solenoid control valves
- Custom designed magnet housings
- Alternate magnetic circuits for specific lifting requirements
- Magnet mounted control valves
- Magnets designed into ergonomic lifting systems

For more information on this product, contact us by phone, email or visit our website to request Tech Sheet AG-01B.

## ■ Transporter® LP Low Profile (TLP)



### Low Profile (TLP) Transporter® Magnets

The Transporter® LP is designed to directly replace vacuum cups with minor tooling and valve adjustments. Powerful Rare Earth magnets positively hold the parts during transfer, greatly reducing the chance of slipping and shifting of your part due to oily coatings. An optional “low-skid” boot is also available to increase grip on parts during transfer. A short burst of shop air pressure is applied in order to release parts.

### Applications & Benefits

- Automated press to press transfer systems
- Robotic “Pick & Place”
- Manual and automated machine loading/unloading
- Outlasts vacuum cups in most applications
- Grasps odd shaped or perforated parts
- Increases production and reduces shop air costs
- Designed for long, maintenance-free operation
- Operates effectively in any orientation
- Will not drop parts if system air-loss occurs
- Class “A” blank protection with covered magnets
- Destacks without double-blanking with the right magnet for the application
- Reduces noise
- Powerful Rare Earth magnet positively holds parts - no dropping or shifting in the event of air loss
- Threads onto a variety of typical 3/8 NPT vacuum cup tooling, including quick disconnect adapters
- TLP30 Models available with optional 3/8 BSPP Fitting - British Standard Pipe Parallel Thread
- Lightweight, low-profile design for minimal die clearance
- Easy installation on existing tooling booms or robotic face plates
- Instantaneous pick-up and release
- Uses up to 95% less air than vacuum cups

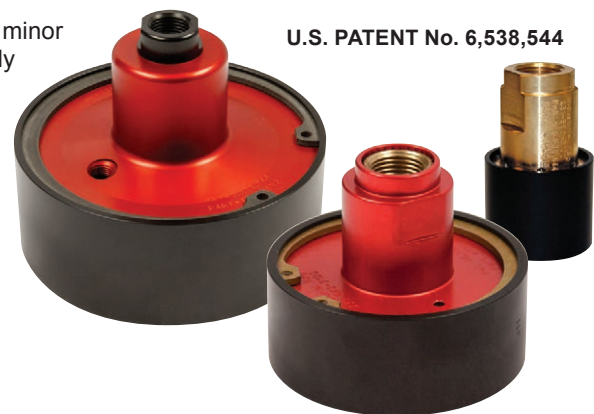

For more information on this product, contact us by phone, email or visit our website to request Tech Sheet AG-01C.

## ■ Transporter® MagVac (TPMV)

The Transporter® MagVac combines magnet technology with vacuum cups to create a next generation lifting tool.

### Benefits

- Powerful magnetic gripper combined with a vacuum cup for powerful holding
- Lift steel or perforated parts as well as aluminum and stainless steel
- Perfect for robotic systems, press transfer systems and all sheet metal applications
- Vacuum pads can be removed for single use as a standard lift magnet on ferrous parts
- No more replacing vacuum cups every week
- No dropping parts from loss of air (for ferrous parts), excess mill oil or weld slag
- Maximum temperature of 176°F (80°C)
- All suction cup pads are made from Thermoplastic Polyurethane/TPU



For more information on this product, contact us by phone, email or visit our website to request Tech Sheet AG-01E.

## ■ Lift Assists



Transporter® Technology is the use of permanent magnets to hold, lift and convey ferrous metal objects with the On/Off capabilities similar to an electromagnet. These permanent magnets use only a short blast of shop air to move the magnet away from the steel it is holding. Once the magnet is moved away from the steel, air gap is created and the part is released. If a power outage occurs during use, the “fail safe” of this tooling is always “ON”, protecting product and equipment from damage also reducing the chance of employee injuries.

IMI specializes in designing the right Transporter® magnet for your application based on the shape, weight and dimension of the part, how it is moved and the orientation of the part. IMI integrates Transporter® magnets with end-of-arm tooling, intelligent lift devices, under-the-hook lifting, robotic and PLC controlled systems. Let IMI design a material handling solution for you.



## ■ Custom Length Channel Magnets



An additional center mounting hole is provided on channel magnets that are 24” or longer. Special mounting available upon request. Ceramic Magnet. Channel is 9/16” thick.

### Features

- Full length magnetic holding force
- Countersunk holes for mounting

\*CUSTOM LENGTH -To be specified by customer.  
Most common lengths range from 12” to 48”.



Pull (lbs/in)	Wd. (in)	Model No.
1.5	3/4	MR1800
2.7	1	MR1900
5	1-3/8	MR2000
5.7	1-5/8	MR2100
6.5	2-3/8	MR2101

## ■ Magnetic Sheet Lift Systems



The Magnetic Sheet Lifter de-stacks steel sheets from pallets, racks and more. The unique design of this permanent magnetic lifting system allows one person to safely and effectively move and load sheets onto cutting tables, shear beds and other fabrication equipment.

The Magnetic Sheet Lifter features a series of adjustable position permanent magnet lifting heads to lift a wide variety of sheet lengths and widths. Push button controls activate the air cylinders located on the magnetic heads. Once activated, the cylinders lift the magnets up into a housing and release the sheet in its desired location.



### Applications

- Stacking and destacking sheet steel
- Loading shears, punch presses, press brakes and burn tables
- Moving sheets/plates from pallets or racks to work stations

### Benefits

- Allows one person to safely move sheet steel
- Reliability of a permanent magnetic lift with the On/Off capabilities similar to an electromagnet
- Fail-safe design (No battery backup required)
- Adjustable magnet positions lift a wide variety of sheet lengths and widths.
- Operates without the heat build up of electromagnets
- Won't drop load due to power outages or system air loss
- Only requires shop air for operation

### Features & Specifications

- Transporter® Technology Magnets
- Structural tube framework
- Durable, welded construction
- Pneumatic release buttons on handles
- Adjustable magnet head assembly locations
- Pneumatic control valve provided
- 1/2 NPT inlet fittings
- Filter regulator with pressure gauge

**For more information on this product, contact us by phone, email or visit our website to request Tech Sheet AG-03A.**

## ■ Vacuum Lift Systems

### Benefits

- Increase productivity, reducing cost
- One person operation
- Eliminate material damage
- Versatile handling of most materials
- Improve storage space
- Provide a low maintenance lifter
- Durable for long lasting service

### Features

- Ball mounted vacuum pads
- Push lock hose (designed for 250 psi)
- Individual slide valve for each vacuum pad allows manual isolation of vacuum pads not needed for attachment
- Muffler is spin on type for easy change out
- Conforms to ASME B30.20 standards

Single Pad

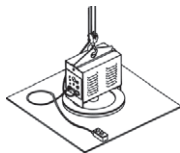

Twin Pads

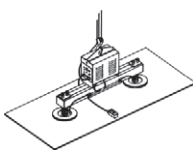

Quad Pads

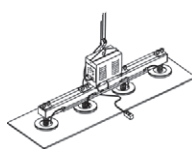

Twin Crossarms

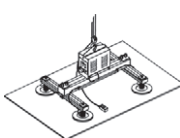

Triple Crossarms

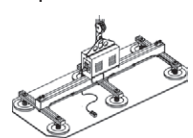

Quad Crossarms

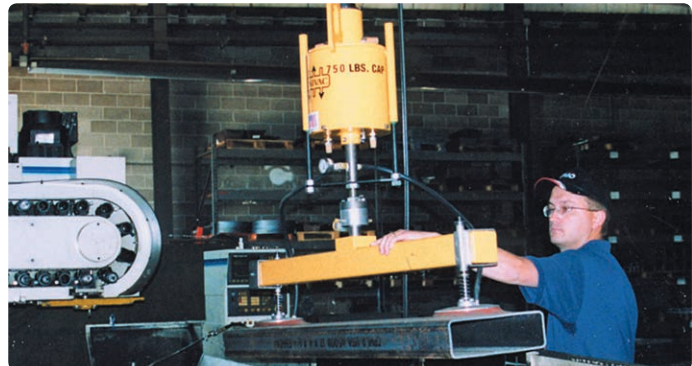
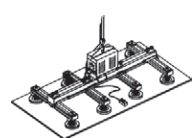

**For more information on this product, contact us by phone, email or visit our website to request Tech Sheet AG-04A.**



## ■ Magnetic Tube Lift Systems

The Magnetic Tube Lifter transfers steel tubes from pallets, racks, work stations and more. The unique design of this permanent magnetic lifting system allows one person to safely and effectively move and load steel tubing in manual applications. Tube lifters can also be designed for automated applications to transfer tubes within a system. The Magnetic Tube Lifter features specially designed permanent magnetic lifting heads to lift a variety of tube shapes, diameters and wall thicknesses. To release tubes from the powerful magnetic heads, air cylinders located on the magnet assemblies are activated lifting the magnets up inside of the housing, allowing the tubes to be set down in the desired location.



### Applications

- Loading/Unloading saws, cutting stations, welding cells and pallets
- Transferring tubes for hydroforming
- Moving single or multiple tubes between work stations
- Packaging, palletizing & depalletizing

### Benefits

- Works on round, square & custom shaped tubing
- Reliability of a permanent magnetic lift with the On/Off capabilities of an electromagnet
- Fail-safe design (No battery backup required)
- Won't drop tubes due to system power or air loss
- Requires only shop air for operation

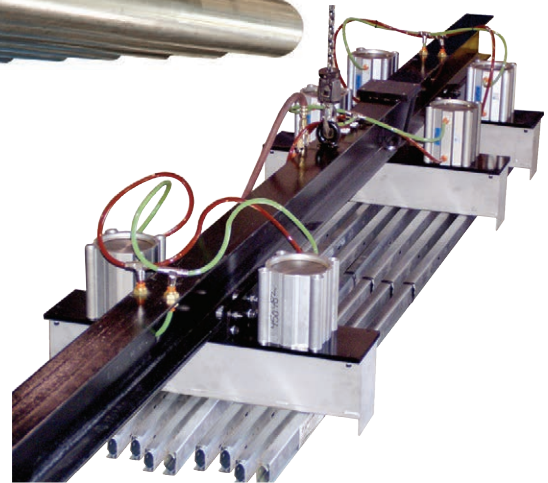

For more information on this product, contact us by phone, email or visit our website to request Tech Sheet AG-03B.

## ■ Magnetic Palletizers and Depalletizers



**Transfer steel items that need to be palletized or depalletized safely & efficiently!**

Custom designed to increase production and reduce product damage, IMI's Magnetic Palletizers/Depalletizers provide a safe and efficient method of transferring items to or from pallets, boxes or cartons. The powerful permanent magnetic heads securely transfer products from accumulators to shipping containers without the need for additional holding devices.

Typically equipped with pneumatic releases, Palletizers/Depalletizers are ideal for automated processes such as full or empty food and beverage cans, brake drums and rotors, jars with steel lids, paint cans, composite cans, batteries and more!

### Benefits

- Reliability of a permanent magnet with the On/Off capabilities of an electromagnet
- Increased production for palletizing or depalletizing steel items
- Reduced repetitive labor
- Versatility in manual or automated applications, including automated sorting and counting of products

For more information on this product, contact us by phone, email or visit our website to request Tech Sheet AG-03C.

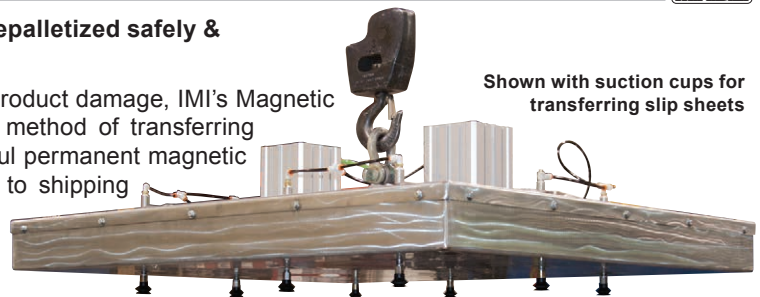

Shown with suction cups for transferring slip sheets



## ■ Conveyors - Low Profile

### Features

- Available in Magnetic and Non-Magnetic models
- Standard sizes to match your application requirements
- Low overall clearance design requires minimal installation space
- Magnetic unit circuits are the same width as the belt to hold parts firmly from edge to edge
- Low profile design allows for fast belt replacement, reducing downtime
- Oil and abrasion resistant urethane belts
- Endless belts for longer belt life and less maintenance
- Crowned take-up pulleys for accurate belt tracking
- Designed for easy tracking and take-up adjustments
- Crowned drive pulleys are knurled for positive belt traction and accurate alignment
- Gang or individual drive options are available

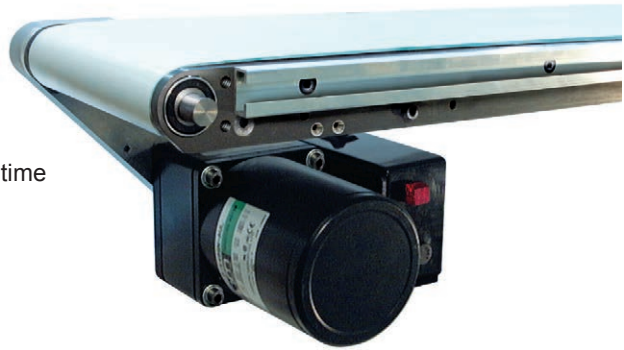

For more information on this product, contact us by phone, email or visit our website to request Tech Sheet AG-08C.

## ■ Conveyors - Transferring & Feeding



Magnetic Transfer Conveyors are ideal for automating sheet handling in various industries including: Automotive, Appliance and Office Furniture. Magnetic Transfer Conveyors contain permanent, Perm-Electro or electromagnetic rails that eliminate costly manual handling and feeding of presses, while increasing production speeds and improving safety.

Maximum sheet size, thickness, weight, surface treatments, length and direction of transfer and the type of operation are all taken into consideration when designing a transfer conveyor for your application.

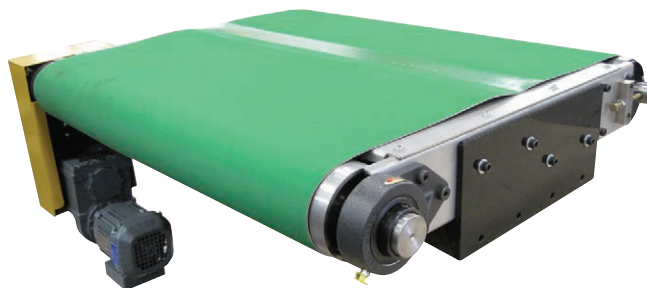

### Applications

- Stacking/Destacking lines
- Part transfer between work stations and presses
- Press feeding
- Coil unloading

### Benefits

- Eliminate laborious hand feeding
- Increase production speeds

### Features

- Easy belt removal opposite of drive side
- Drive system can be mounted on either side of the conveyor and conveyors can be gang driven

For more information on this product, contact us by phone, email or visit our website to request Tech Sheet AG-08B.

## ■ Magnetic Skate Rail



Magnetic Skate Rail is ideal for use in conjunction with Magnetic Transfer Conveyors in stacking, destacking and press feeding applications. These products work together to automate sheet handling in a variety of industries including Automotive, Office Furniture and Appliance.

Typically positioned on the outside edge of a steel blank and parallel to magnetic transfer conveyor(s), the powerful magnets hold steel blanks securely up against a series of rollers, preventing flexing or bending of the sheet as it is conveyed. The neoprene rollers allow blanks to roll easily, without marring, into the press. The magnet position can be adjusted to accommodate the size and thickness of different blanks.

### Benefits

- Prevents bending or flexing of large sheets during transfer, outboard of magnetic conveyors
- Reduces the need for additional magnetic conveyors



### Applications

- Stacking/Destacking Lines
- Press Feeding

### Features

- Powerful permanent magnetic circuit
- Adjustable magnetic strength for different gauges
- Neoprene roller wheels prevent scratching

For more information on this product, contact us by phone, email or visit our website to request Tech Sheet AG-08D.



## ■ Perm-Electro Hybrid Rail

### Applications

- For belt transfer of 22 to 12 gauge flat blanks and sheet stock
- Automated Sheet Handling
- Transfer of parts between presses
- Stacking
- Overhead Conveying

### Benefits

- Automated press feeding
- Controlled Drop Points
- No battery backup required

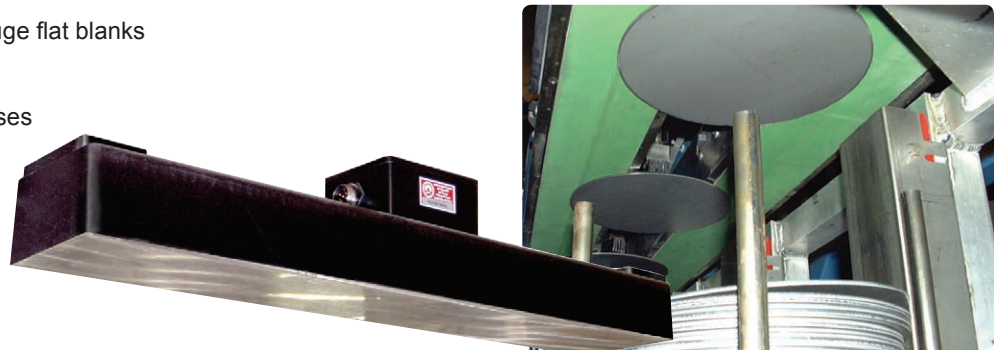

Permanent-Electro Hybrid Rail is commonly used for automated conveying and transferring of steel sheets and parts in various industries including: Automotive, Appliance and Office Furniture. Hybrid Rail eliminates the need for time-consuming manual handling and feeding of presses. Magnetic hybrid rail increases production speeds and improves safety.

Hybrid Rail utilizes a powerful permanent magnetic circuit to move and hold steel objects during conveying. The coil is only energized for the amount of time required to release the part from the conveyor belt. This particular product is a permanent magnet with an electrical release. This fast acting On/Off action enables the magnets to be controlled for specific drop points throughout the conveying system.

For more information on this product, contact us by phone, email or visit our website to request Tech Sheet AG-08F.

## ■ Electromagnetic Conveying Rail



Magnetic Electro-Rail is commonly used for automated conveying, transferring and lifting of steel sheets and parts in various industries including: Automotive, Appliance, and Office Furniture. Electro-Rail eliminates the need for costly and time-consuming manual handling and feeding of presses. Magnetic Electro-Rail increases production speeds and improves safety.

Using a powerful electromagnetic circuit to move and hold steel objects during conveying, these electromagnets provide On/Off capability and allow the user to control drop points throughout the system.

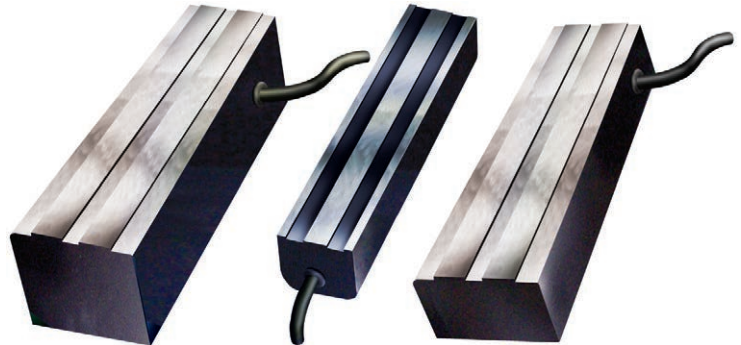

For more information on this product, contact us by phone, email or visit our website to request Tech Sheet AG-08E.

## ■ Permanent Conveying Rail & Rolls/Pulleys



Magnetic Conveying Rail utilizes powerful permanent magnets to hold ferrous parts such as steel containers, composite cans, lids and more firmly in place during conveying. The magnetic rail is installed as a stationary component and allows the conveyor belting to ride over the top of it. The strong magnetic field holds parts tightly to the belt surface, even during vertical, inclined or horizontal conveying. Conveying speeds can be increased while eliminating the slipping or rolling of items.

### Benefits

- Increased production rates
- Uniform part orientation and holding
- Powerful Permanent Magnets
- Straight, curved or radius designs

Additional benefits include better utilization of space within a facility, noise reduction, correct part orientation and on-time material flow. IMI has a full line of quality magnetic components available in a wide variety of sizes and strengths to meet your application needs.

For more information on this product, contact us by phone, email or visit our website to request Tech Sheet AG-06B.



# MAGNETS

HOLDING • LIFTING • FIXTURING • FABRICATION • WELDING AND MORE



## MAG-MATE®

Magnetic Assemblies for Workholding, Lifting, Fixturing, Transferring, Sweeping, Welding, Tools, Raw Material & More

### Key Markets

- Fabrication
- Metalworking
- Welding
- Sling & Rigging
- Governments

## AUTOMATION

Engineered Industrial Magnetic Solutions for Automated Stacking, Destacking, Conveying, Lifting, Transferring, Tooling & Fanning of Metals

### Key Markets

- Automotive / Tier 1 & 2
- Stamping
- Heavy Equipment Fabrication
- Conveying
- Office Furniture & Appliance



**INDUSTRIAL MAGNETICS, INC.**  
*Making Things Better®*

1385 S M 75 • Boyne City, MI 49712 • WWW.MAGNETICS.COM  
 Mag-Mate®: 888.582.0822 • Automation: 888.582.0823 • Fax : 231.582.2704



Society of  
Manufacturing  
Engineers



**AFFILIATED**  
DISTRIBUTORS



**ISA**  
INDUSTRIAL SUPPLY ASSOCIATION  
Linking Channel Partners



Distributed By: