

08, 18, 28, 90 Series FRL Products

Compact, Intermediate & Standard Modular Air Preparation Systems

Catalog 605-1 (Updated July 2020)

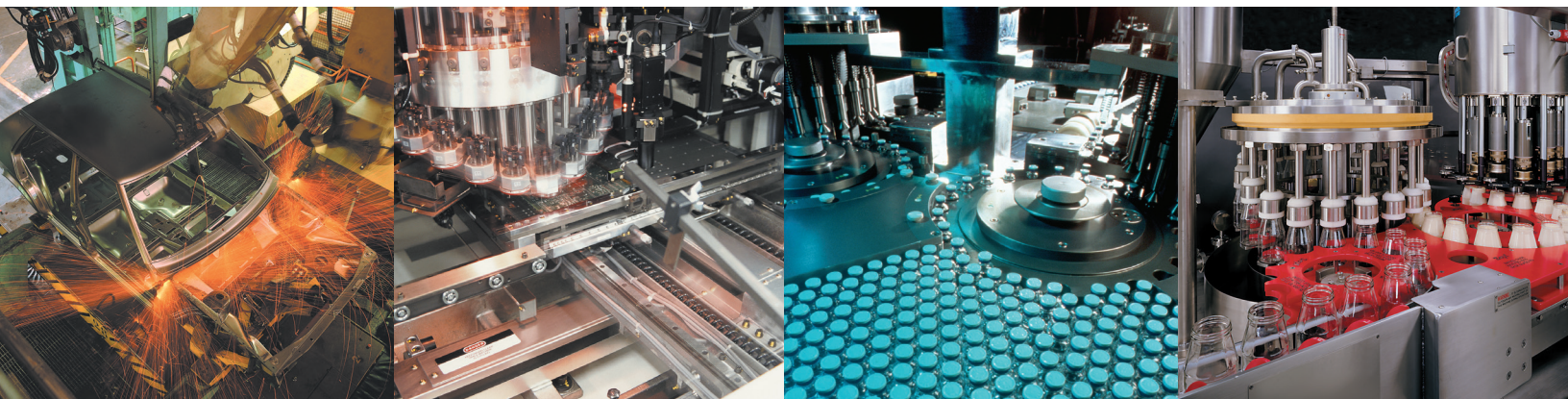

the total systems approach to air preparation

WILKERSON®

First incorporated in August of 1948, Wilkerson manufactures a complete line of compressed air treatment and control products to meet a wide variety of applications. Today, Wilkerson serves over 500 different industries throughout the world.

Over the years, Wilkerson facilities, manufacturing and engineering technology have kept pace with increased sales volume, the growing need to satisfy customers' specific requirements and the demands placed on production.

Wilkerson's growing leadership in the industry is due to our determined commitment to quality; quality of products,

services and people. Our dedication to the total quality management process assures our customers that we can consistently provide the highest levels of product quality and customer service needs.

From the very beginning, Wilkerson has sold its products through a world-wide, independent distributor network. We currently have 200 distributors throughout North America, plus an expanding network of international distributors in over 40 countries. Our distributors, with many years of experience in compressed air treatment and control, offer excellent product knowledge,

technical assistance and local inventory. As a result of representing other complimentary products, they are able to satisfy their customers' total requirements.

Today's broad line of Wilkerson products is the result of continuing product innovations and technology advancements which frequently become industry standards. Wilkerson is dedicated to designing and manufacturing innovative products with features and operating characteristics that meet customer requirements for quality, performance, reliability, serviceability, safety and value.

WARNING

FAILURE OR IMPROPER SELECTION OR IMPROPER USE OF THE PRODUCTS AND/OR SYSTEMS DESCRIBED HEREIN OR RELATED ITEMS CAN CAUSE DEATH, PERSONAL INJURY AND PROPERTY DAMAGE.

This document and other information from The Company, its subsidiaries and authorized distributors provide product and/or system options for further investigation by users having technical expertise. It is important that you analyze all aspects of your application including consequences of any failure, and review the information concerning the product or system in the current product catalog. Due to the variety of operating conditions and applications for these products or systems, the user, through its own analysis and testing, is solely responsible for making the final selection of the products and systems and assuring that all performance, safety and warning requirements of the application are met.

The products described herein, including without limitation, product features, specifications, designs, availability and pricing, are subject to change by The Company and its subsidiaries at any time without notice.

Offer of Sale

The items described in this document are hereby offered for sale by The Company, its subsidiaries or its authorized distributors. This offer and its acceptance are governed by the provisions stated on the separate page of this document "Offer of Sale".





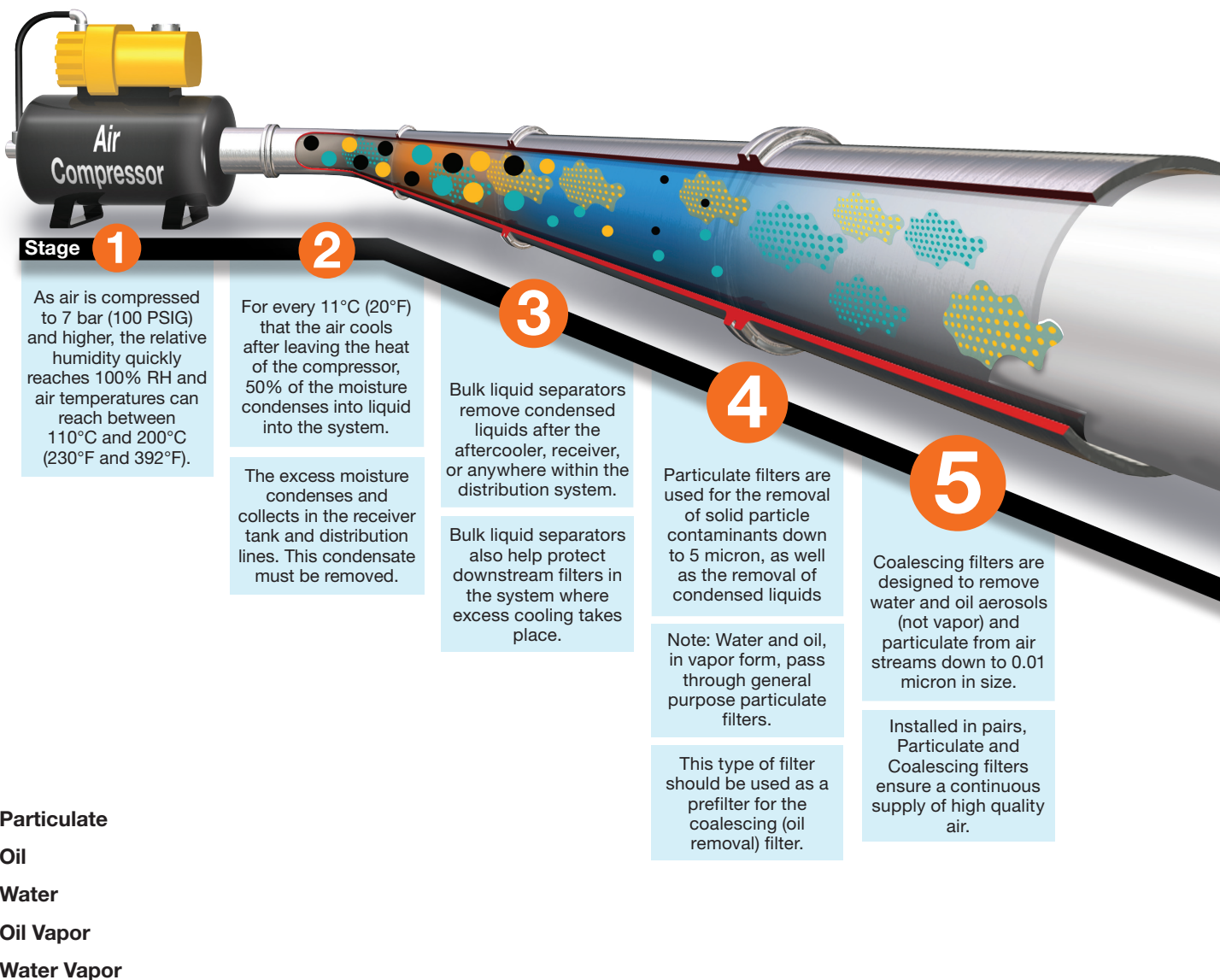

Table of Contents	
Features	2-7
Particulate Filters.....	9-17
Coalescing Filters.....	19-27
Afterfilters	29-31
Regulators	33-43
Common P1 Regulators.....	45-49
Lubricators.....	51-59
Filter / Regulators.....	61-69
Combinations	
2-Unit - Filter / Regulators, Lubricator	71-79
3-Unit - Filter, Regulator, Lubricator.....	81-89
Accessories	91-124
Kits and Parts	125-132
Safety Guidelines	133-134
Offer of Sale	135

Together we can power your application with clean, dry air

Fast cycle times, high product quality, and low downtime all require a clean, dry pneumatic system to function properly. Wilkerson has what it takes to make sure pneumatic systems perform at their best.

Clean, dry pneumatic systems with Wilkerson Air Preparation



						
Stages	1 2	3	4	5	6	7
Function	Air Compressor	Bulk Liquid Removal	Particulate Filtration	Coalescing Filtration	Air Dryers	Hydrocarbon Removal
Application	All pneumatic systems	Basic pneumatic systems	Basic pneumatic systems	Systems requiring highest quality air.	Systems requiring air with reduced moisture content	Systems requiring highest quality air for critical applications
Description	Air leaving the compressor room at 93°C (200°F) releases 95% of its moisture into the piping system when it cools to 38°C (100°F)	Removes bulk liquid contamination and protects filters where excess cooling takes place in the distribution piping	Removes solid particulates down to 5 micron, and the separation of bulk contaminants.	Removes liquid aerosols and submicron particulates (not vapor) down to 0.01 micron.	Removes water vapor from air stream. Dew point reduced down to 4°C (40°F) (refrigeration) or -40°C (-40°F) (desiccant).	Removal of odors and trace vapors for critical applications.
Wilkerson Air Preparation Solution	Customer supplied	WSO, WSA Bulk Liquid Separator	08, 18, 28 Particulate Filter	08, 18, 28 Coalescing Filter	Refrigeration Dryer, TW Regenerative Desiccant Dryer	18, 28 Activated Carbon (Adsorber) Filter

Clean Dry Air

6

Refrigeration and desiccant dryers lower the air's dew point by removing water vapor, providing appropriately dry air for the downstream application.

7

Hydrocarbon and oil vapors are removed using filters utilizing activated carbon.

Airborne hydrocarbons are often left over from the compressor oils.



DECLARATION OF COMPLIANCE (ROHS)

European Directive 2011/65/EU – RoHS (Restriction us of certain Hazardous Substances in electrical and electronic equipment), restricts the use of the 6 substances in the manufacture of specified electrical equipment.

Lead: Product containing lead and its compound (except for applications of lead as an alloying element by weight in steel up to 0.35%, in aluminum up to 0.4% and in copper alloys up to 4% and in circuit board solder) must not exceed 0.1% by weight

Mercury: The concentration level must not exceed 0.1% by volume

Cadmium: The concentration level must not exceed 0.01% by volume

Hexavalent Chromiou:

This is a corrosive protective finish used on our product line. Where this finish is utilized the Chromate solution is Hexavalent (Chrome 6) free.

Polybrominated Biphenyls (PBB):

The concentration level must not exceed 0.1% by weight. This substance is not know to be in any of our products.

Polybrominated Diphenyl Esters (PBDE):

The concentration level must not exceed 0.1% by weight. This substance is not know to be in any of our products.



Following Ignition Hazard Assessments performed on the non-electrical Global Air Preparation products they are in accordance with the requirements of EN 13463-1:2009, it was considered that the equipment does not contain its own source of ignition, and therefore is not within the scope of directive 94/9/EC.

The products can be used in a Group II Category 2 environment assuming that the ATEX Directive and the following conditions are complied with:

- Installation and maintenance of the product must be undertaken by qualified personnel.
- Do not mount the products in an area where impact may occur.
- Filters must be used to limit the introduction of particles and to capture particles generated in service.
- Supply air quality must be within ISO 8573-1:2010 Class 1.4.2.
- Maximum working temperature to be as stated on product label.
- WARNING – pulsating pressure and/or a closed circuit can generate heat.
- Deposits of dust on the product must not exceed 5mm thickness. Refer to technical file for surface areas of plastics. The unit must be earthed via the compressed air supply line.
- The unit must not come into contact with liquid solvents, acids or alkalis. Refer to technical file for chemicals known to be incompatible. Product cleaning must be undertaken using a method complying with the specifications of the ATEX zone, preferably by using mild soap and water or antistatic products.
- Regulators, Filter Regulators: Do not use Regulators or Filter Regulators within systems that can create vibration within the Regulator / Filter Regulator unit.
- Solenoid Operated Valves: Are suitable for use in an ATEX environment, (Group II Category 2) providing ATEX approved solenoids are fitted.
- Technical file available on request.



Global Air Preparation products supplied by Parker Hannifin have been designed and manufactured in accordance with “sound engineering practice”, as defined by Article 3 of Pressure Equipment Directive 97/23/EC.



Global Air Preparation product range is in compliance with REACH to ensure continued compliance additions to the list of SVHC (Substance of Very High Concern) are reviewed periodically.

Global Air Preparation product range has been third party Shock & Vibration tested independently in accordance to EN 61373 : 1999, Category 2



Global Air Preparation product range has been designed and tested in accordance with ISO flow testing, envelope integrity, and catalog data presented.

- Filters – ISO 5782-1 & ISO 5782-2: 1997
- Regulators – ISO 6953-1 & ISO 6953-2: 2000
- Lubricators – ISO 6301-1 & ISO 6301-2: 2009

! WARNING

FAILURE OR IMPROPER SELECTION OR IMPROPER USE OF THE PRODUCTS AND/OR SYSTEMS DESCRIBED HEREIN OR RELATED ITEMS CAN CAUSE DEATH, PERSONAL INJURY AND PROPERTY DAMAGE.

This document and other information from Parker Hannifin Corporation, its subsidiaries and authorized distributors provide product and/or system options for further investigation by users having technical expertise. It is important that you analyze all aspects of your application including consequences of any failure, and review the information concerning the product or system in the current product catalog. Due to the variety of operating conditions and applications for these products or systems, the user, through its own analysis and testing, is solely responsible for making the final selection of the products and systems and assuring that all performance, safety and warning requirements of the application are met.

The products described herein, including without limitation, product features, specifications, designs, availability and pricing, are subject to change by Parker Hannifin Corporation and its subsidiaries at any time without notice.

Offer of Sale

The items described in this document are hereby offered for sale by Parker Hannifin Corporation, its subsidiaries or its authorized distributors. This offer and its acceptance are governed by the provisions stated on the separate page of this document entitled “Offer of Sale”.

Compact Modular 08 Series



Filter

The F08 compact filter features a 5 micron particulate element, quick disconnect plastic bowl with bowl guard and a manual pipe away type manual drain. Quick disconnect metal bowls and piston automatic drains are additional available options. Wilkerson F08 filters meet or exceed ISO class 3 for maximum particle size retention and removal.



Regulator

The R08 compact regulator features a balanced valve for superior regulation characteristics, two gauge ports, and a bottom plug for ease of maintenance serviceability. The unique flush-mounted pressure gauge is available as an option.



Coalescing Filter

The M08 compact coalescing filter provides high efficiency removal of water, oil aerosols and solid particulate contaminants down to .01 micron in size. The M08 comes standard with quick disconnect plastic bowl with bowl guard and a manual pipe away type manual drain. Quick disconnect metal bowls and piston automatic drains are additional available options.



Lubricator

The L08 compact lubricator features an integral clear sight dome and adjustment knob for quick setting of the lubrication rate. The L08 can also be replenished with oil while under pressure by using the 1/8" fill plug at the top of the unit.



Filter / Regulator

The B08 compact integral filter / regulator combines all the advanced features and functions of the standard filter and regulator into a single, space saving, high performance unit.



Filter / Regulator - Lubricator Combination

The D08 compact modular combination model brings together all the superior features and functions of the 08 series modular FRL product line into a compact, lightweight assembly.

Compact Modular 08 Series

Accessories and Options



Diverter Block

For increased design flexibility, the N08 diverter block is available with 1/4" threaded inlet / outlet ports. The diverter block can be mounted anywhere in the FRL system. The unit comes with two, 1/4" or 1/8" threaded auxiliary ports.



Modular Lockout Valve

The V40 modular lockout valve is a 40mm ball valve style with the ability to modularly mount into any standard 08 series assembly. It provides shut off line pressure with a non-sticking 90° turn handle to prevent unauthorized adjustment.



Metal Bowl and Automatic Piston Drain

The 08 series has both optional metal bowl and automatic cyclic piston drain to meet your application needs.

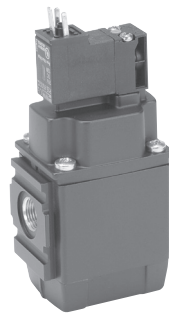

Combined Soft Start / Dump Valve

The E09 series combined soft start / dump valve provides for the safe introduction of pressure to machines or systems. Soft start / dump valves when set, allow the pressure to gradually build to the set point before fully opening to deliver full flow at line pressure.



Flush Mount Pressure Gauge

The 08 & 18 series Regulator features an attractive, square-housing, flush mount pressure gauge (0-160 PSIG) that can be mounted on either side of the regulator for piping convenience. Standard 1/8" NPT gauge ports and gauges are also available.

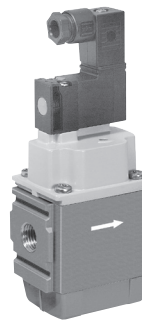

Dump Valve

The Q09 series dump valves 3-way, 2-position function automatically dumps downstream pressure on the loss of pilot signal. It features both solenoid or air pilot options. Silencer included.

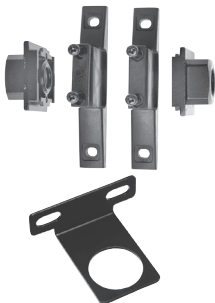

Modular Brackets and Joiner Assembly

A wide choice of unit mounting brackets and joiner assemblies allow for easy unit installation, assembly, and mounting.



Proportional Pressure Regulators

The ER09 proportional pressure regulators provide all the advantages of a closed circuit regulated system. When a set value is defined via the input signal (e.g. 0-10 V), the pressure regulator sets the corresponding output pressure (e.g. 0-150 PSI / 0-10 bar). At the same time the integrated pressure sensor measures the actual pressure at the unit's outlet (actual value).

Compact Modular 08 Series

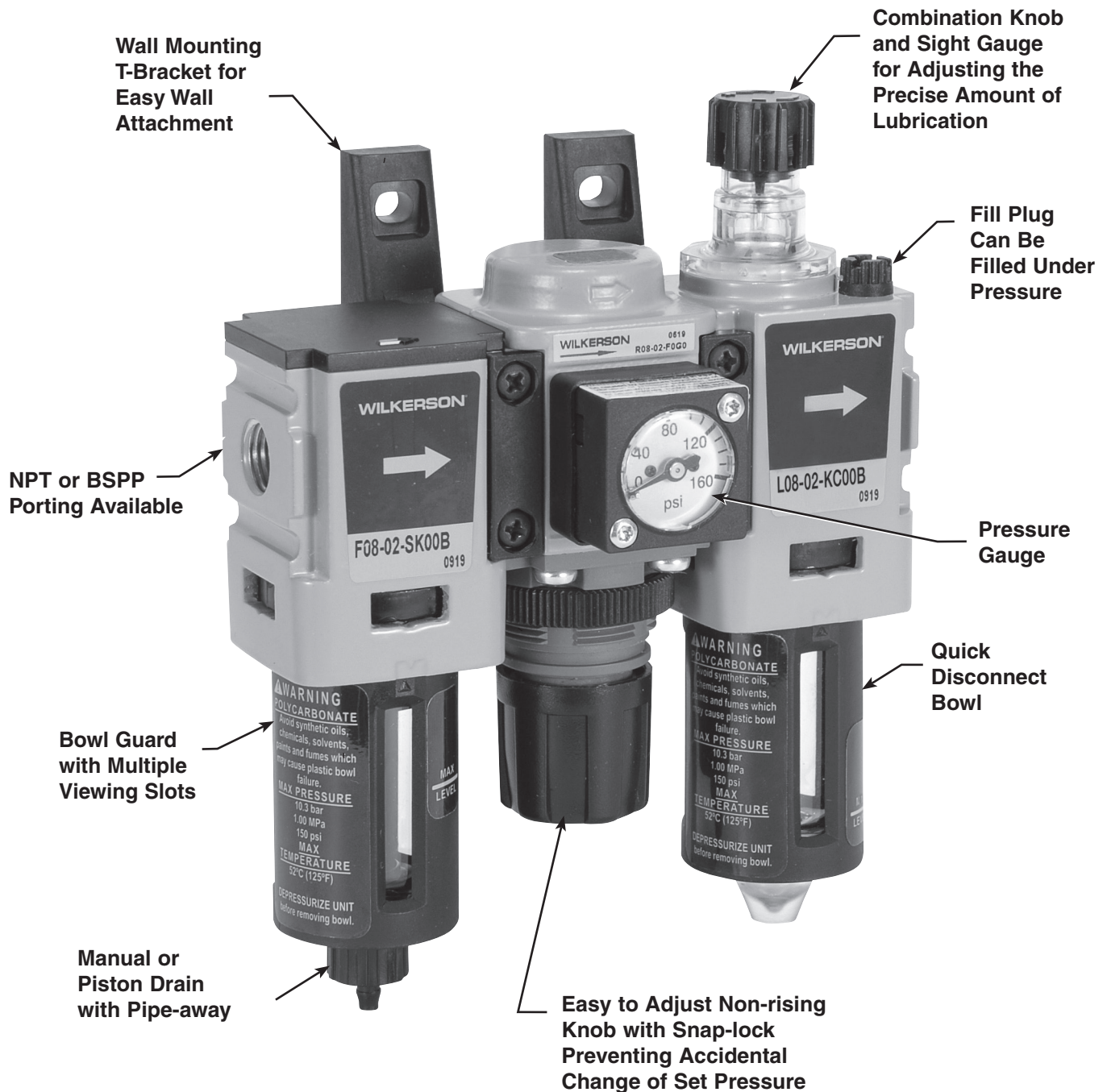

Filter / Regulator / Lubricator Combination Units

The C08 modular FRL combination model integrates components of the advanced “08” product line into a compact, lightweight, ready-to-mount assembly. The units come standard with pressure gauge and are

pre-assembled utilizing our modular T-bracket / joiner assembly for easy installation and mounting.

Notes

Particulate Filter Numbering System

 = "Most Popular"

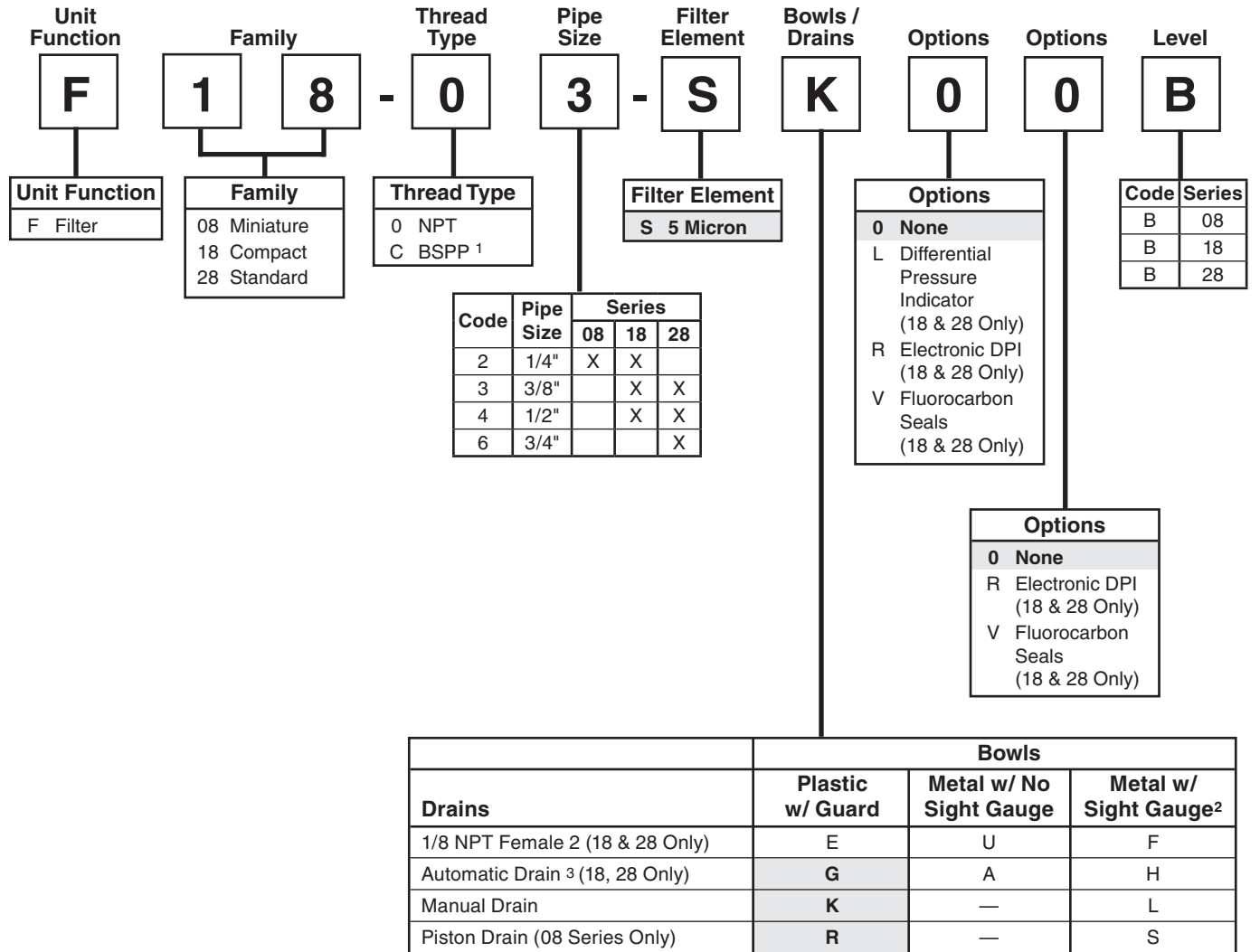

¹ ISO, R228 (G Series)

² F08 Filter has an all Metal Bowl (no sight gauge)

³ Operating range 15 to 250 PSIG (1 to 17 bar)

"F" Series Filters, Type "A" 5 micron elements: All Wilkerson Type "A" 5 micron elements **meet or exceed** ISO Class 3 for maximum particle size and concentration of solid contaminants.

NOTE: All classes above refer to International Standards Organization (ISO) standard 8573-1, pertaining to maximum particle size and concentration of solid contaminants, and maximum oil content.

Note: When selecting from the options columns, please enter letters in alphabetical order for positions 7, 8, and 9. For example:

F 1 8 - 0 3 - S K 0 0 B

Particulate Filter F08

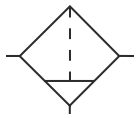

Manual Drain

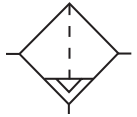

Auto Drain



Features

- Standard 5 Micron Filtration
- Quick-disconnect Bowl
- Bowl Guard
- High Flow Capacity

Specifications

Flow Capacity*	1/4	42 SCFM (20 dm ³ /s, ANR)
Maximum Supply Pressure	Plastic Bowl	150 PSIG (10.3 bar)
	Metal Bowl	250 PSIG (17.2 bar)
Operating Temperature	Plastic Bowl	14° to 125°F (-10° to 52°C)
	Metal Bowl	14° to 150°F (-10° to 65.5°C)
Port Size	NPT / BSPP-G 1/4	
Bowl Capacity	0.6 oz	
Standard Filtration	5 Micron	
Weight	0.24 lb. (0.11 kg)	

* Inlet pressure 91.3 psig (6.3 bar). Pressure drop 4.9 psig (0.34 bar).

“F” Series Filters, Type “A” 5 micron elements: All Wilkerson Type “A” 5 micron elements **meet or exceed ISO Class 3** for maximum particle size and concentration of solid contaminants.

Materials of Construction

Baffle	Acetal	
Body	Aluminum	
Body Cap	ABS	
Bowl	Plastic Bowl	Polycarbonate
	Metal Bowl	Aluminum
Bowl Guard	Nylon	
Element Retainer	Acetal	
Filter Element	Sintered Polyethylene	
Seals	Plastic Bowl	Nitrile
	Metal Bowl	Nitrile

Air quality:

Within ISO 8573-1: 1991 Class 3 (Particulates)
Within ISO 8573-1: 2001 Class 6 (Particulates)

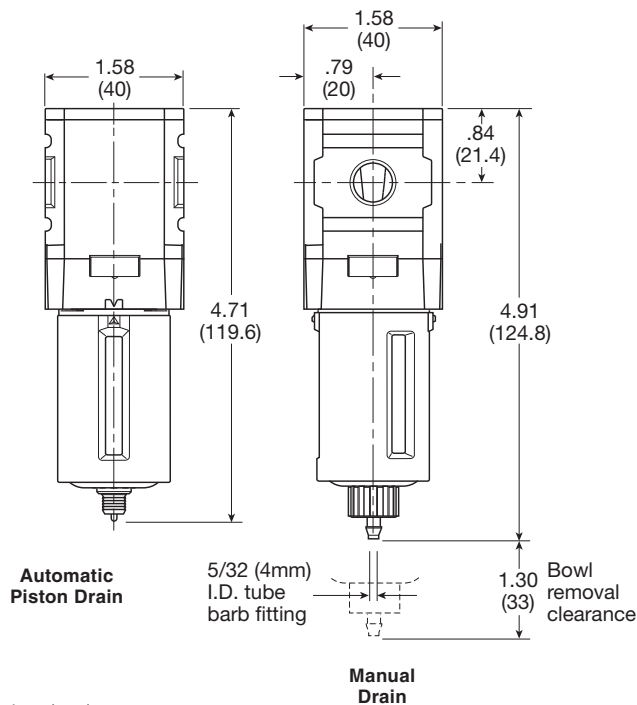

Inches (mm)

= "Most Popular"

Replacement Bowl Kits

- Metal Bowl, Manual Drain.....GRP-96-714
- Plastic Bowl / Bowl Guard, Manual Drain.....GRP-96-712

Replacement Element Kit and Bowl Seal

- Type "A", 5 Micron FRP-96-729

Accessories

- Automatic Piston DrainGRP-96-716
- Wall Mounting Bracket –
- C-Type GPA-97-010
- T-Type GPA-96-737

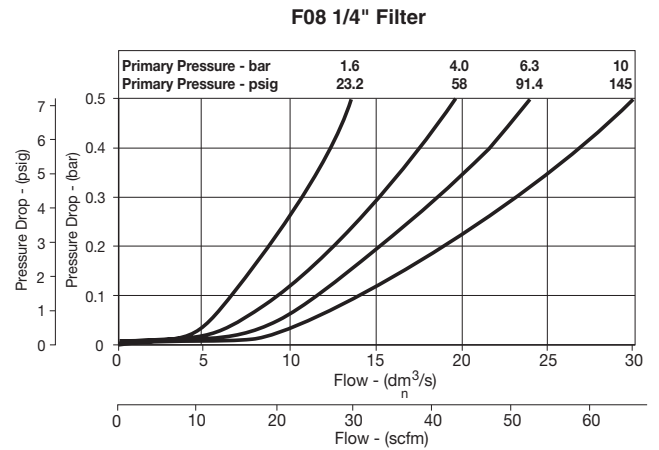

Ordering Information

Model Type	Port Size	Plastic Bowl / Bowl Guard	Metal Bowl (No Sight Gauge)
Manual Drain	1/4	F08-02-SK00B	F08-02-SL00B
Automatic Piston Drain	1/4	F08-02-SR00B	F08-02-SS00B

Options - To order an option supplied with the unit model, Add the appropriate coded suffix letter in the designated position of the model number.

Particulate Filter F18

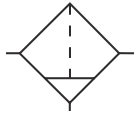

Manual Drain

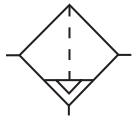

Auto Drain



Specifications

Flow Capacity*	1/4	50 SCFM (24 dm ³ /s, ANR)
	3/8	78 SCFM (37 dm ³ /s, ANR)
	1/2	82 SCFM (39 dm ³ /s, ANR)
Maximum Supply Pressure	Plastic Bowl	150 PSIG (10.3 bar)
	Metal Bowl	250 PSIG (17.2 bar)
Operating Temperature	Plastic Bowl	-13° to 125°F (-25° to 52°C)
	Metal Bowl	-13° to 150°F (-25° to 65.5°C)
Port Size	NPT / BSPP-G 1/4, 3/8, 1/2	
Bowl Capacity	1.72 oz	
Standard Filtration	5 Micron	
Weight	0.62 lb. (0.28 kg)	

* Inlet pressure 91.3 psig (6.3 bar). Pressure drop 4.9 psig (0.34 bar).

“F” Series Filters, Type “A” 5 micron elements: All Wilkerson Type “A” 5 micron elements **meet or exceed ISO Class 3** for maximum particle size and concentration of solid contaminants.

Features

- Standard 5 Micron Filtration
- High Flow Capacities
- 1/2" NPT / BSPP-G Over-port
- Quick-disconnect Bowl
- Bowl Guard
- Light Weight
- Barbed Manual Drain Connection with Pipe-away

Materials of Construction

Body	Aluminum	
Body Cap	ABS	
Bowls	Plastic Bowl	Polycarbonate
	Metal Bowl	Aluminum
Bowl Guard	Nylon	
Deflector	Polypropylene	
Element Retainer / Baffle	Acetal	
Filter Element	Sintered Polyethylene	
Seals	Plastic Bowl	Nitrile
	Metal Bowl	Nitrile
Sight Gauge	Metal Bowl	Polyamide (Nylon)

Air quality:

Within ISO 8573-1: 1991 Class 3 (Particulates)
Within ISO 8573-1: 2001 Class 6 (Particulates)

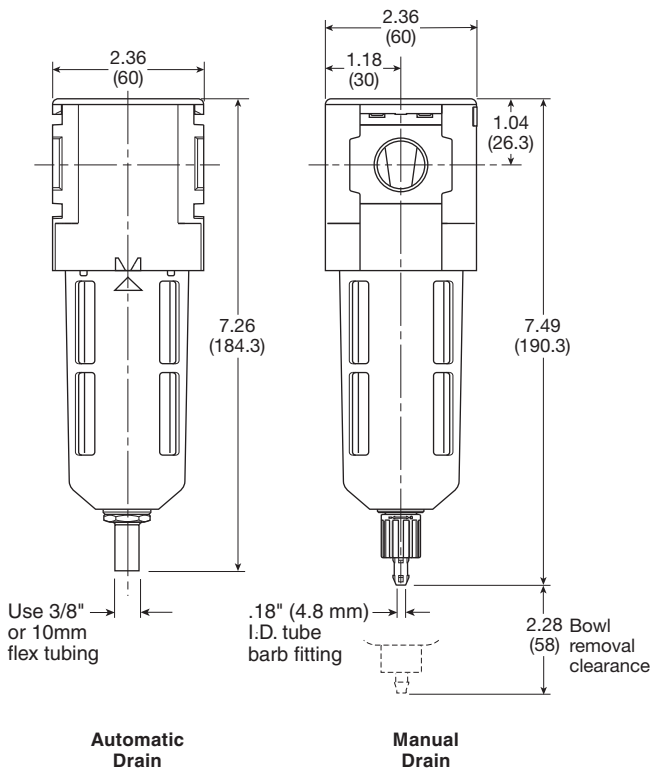

Inches (mm)

= "Most Popular"

Replacement Bowl Kits

- Metal Bowl with Sight Gauge,
Automatic Float Drain..... GRP-96-637
- Metal Bowl with Sight Gauge, Manual Drain..... GRP-96-636
- Plastic Bowl –
Bowl Guard, Auto Drain GRP-96-635
- Bowl Guard, Manual Drain..... GRP-96-634

Replacement Element Kits and Bowl Seal

- Type "A", 5 Micron Element..... FRP-96-639
- Type "A", 5 Micron with Retainer, Deflector,
and Bowl O-ring FRP-96-641

Accessories

- Automatic Drain –
Fluorocarbon GRP-95-981
- Nitrile GRP-95-973
- Manual Drain..... GRP-96-685
- Sight Gauge Kit..... GRP-96-825
- Wall Mounting Bracket –
L-Type GPA-96-604
- T-Type..... GPA-96-602

F18 1/4" Filter

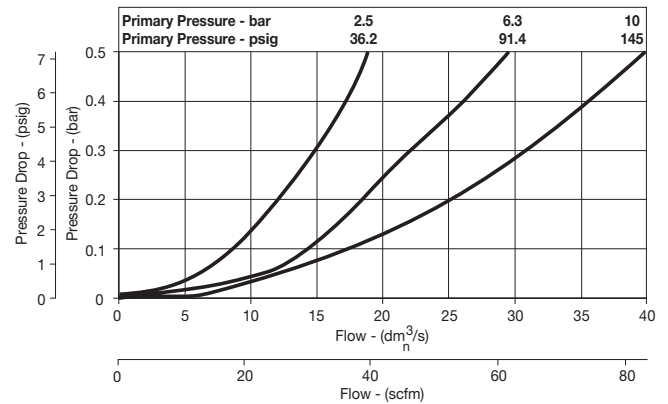

F18 3/8" Filter

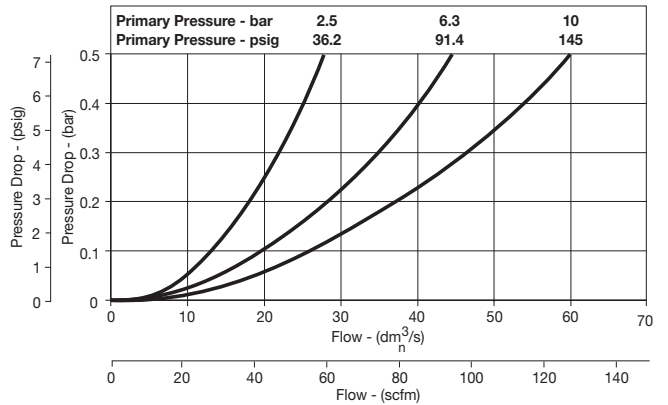

F18 1/2" Filter

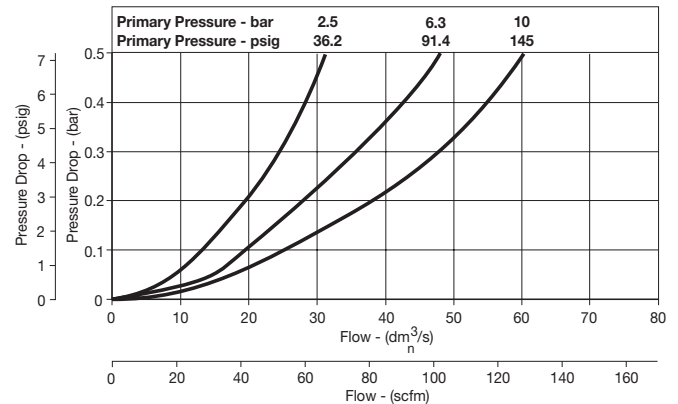

Ordering Information

Model Type	Port Size	Plastic Bowl / Bowl Guard	Metal Bowl / Sight Gauge
Manual Drain	1/4	F18-02-SK00B	F18-02-SL00B
	3/8	F18-03-SK00B	F18-03-SL00B
	1/2	F18-04-SK00B	F18-04-SL00B
Automatic Drain	1/4	F18-02-SG00B	F18-02-SH00B
	3/8	F18-03-SG00B	F18-03-SH00B
	1/2	F18-04-SG00B	F18-04-SH00B

Options - To order an option supplied with the unit model, add the appropriate coded suffix letter in the designated position of the model number.

Particulate Filter F28

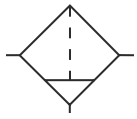

Manual Drain

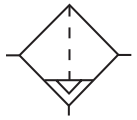

Auto Drain



Features

- Standard 5 Micron Filtration
- High Flow Capacities
- 3/4" NPT / BSPP-G Over-port
- Quick-disconnect Bowl
- Bowl Guard
- Light Weight
- Barbed Manual Drain Connection with Pipe-away

Specifications

Flow Capacity*	3/8	115 SCFM (54 dm ³ /s, ANR)
	1/2	120 SCFM (57 dm ³ /s, ANR)
	3/4	145 SCFM (68 dm ³ /s, ANR)
Maximum Supply Pressure	Plastic Bowl	150 PSIG (10.3 bar)
	Metal Bowl	250 PSIG (17.2 bar)
Operating Temperature	Plastic Bowl	-13° to 125°F (-25° to 52°C)
	Metal Bowl	-13° to 150°F (-25° to 65.5°C)
Port Size	NPT / BSPP-G	3/8, 1/2, 3/4
Bowl Capacity	2.87 oz	
Standard Filtration	5 Micron	
Weight	1.01 lb. (0.46 kg)	

* Inlet pressure 91.3 PSIG (6.3 bar). Pressure drop 4.9 PSID (.34 bar).

“F” Series Filters, Type “A” 5 micron elements: All Wilkerson Type “A” 5 micron elements **meet or exceed ISO Class 3** for maximum particle size and concentration of solid contaminants.

Materials of Construction

Body	Aluminum	
Body Cap	ABS	
Bowls	Plastic Bowl	Polycarbonate
	Metal Bowl	Aluminum
Bowl Guard	Nylon	
Deflector	Polypropylene	
Element Retainer / Baffle	Acetal	
Filter Element	Sintered Polyethylene	
Seals	Plastic Bowl	Nitrile
	Metal Bowl	Nitrile
Sight Gauge	Metal Bowl	Polyamide (Nylon)

Air quality:

Within ISO 8573-1: 1991 Class 3 (Particulates)
Within ISO 8573-1: 2001 Class 6 (Particulates)

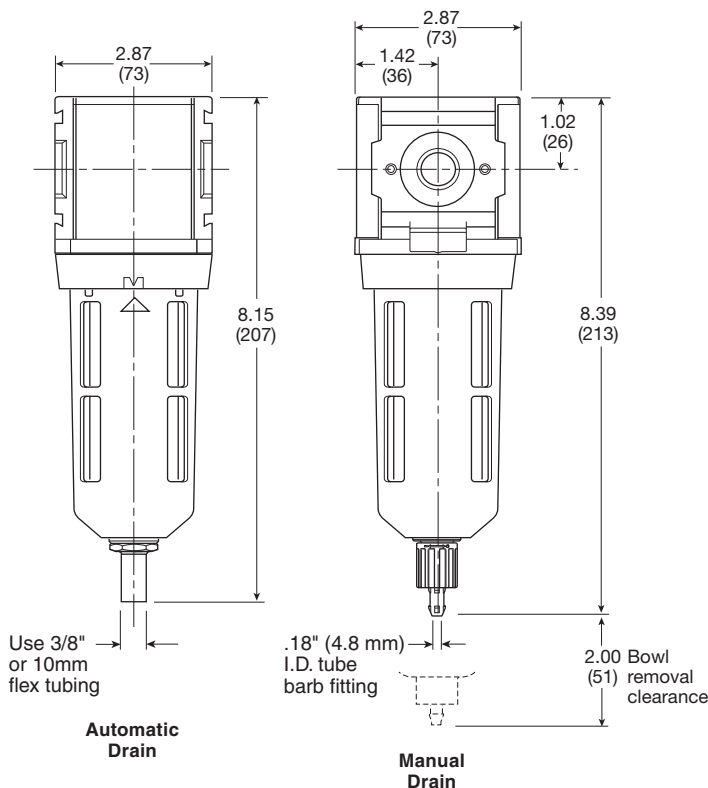

Inches (mm)

= "Most Popular"

Replacement Bowl Kits

- Metal Bowl with Sight Gauge,
Automatic Float Drain..... GRP-96-645
- Metal Bowl with Sight Gauge, Manual Drain..... GRP-96-644
- Plastic Bowl –
Bowl Guard, Auto Drain GRP-96-643
- Bowl Guard, Manual Drain..... GRP-96-642

Replacement Element Kits and Bowl Seal

- Type "A", 5 Micron with Element FRP-96-653
- Type "A", 5 Micron with Retainer, Deflector,
and Bowl O-ring FRP-96-283

Accessories

- Automatic Drain –
Fluorocarbon GRP-95-981
- Nitrile GRP-95-973
- Manual Drain..... GRP-96-685
- Sight Gauge Kit..... GRP-96-825
- Wall Mounting Bracket –
L-Type GPA-96-605
- T-Type..... GPA-96-602

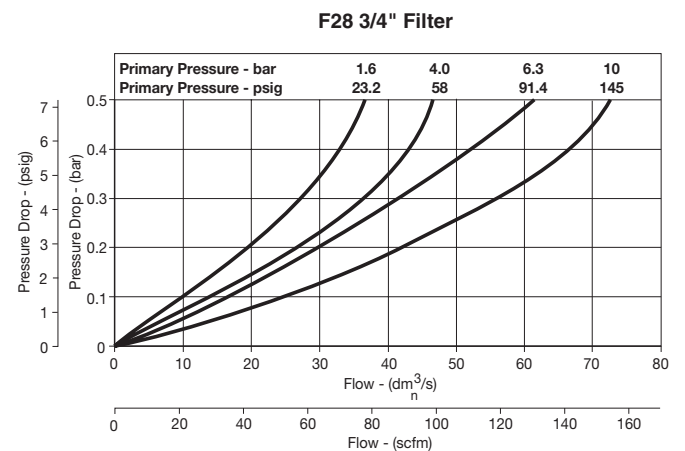
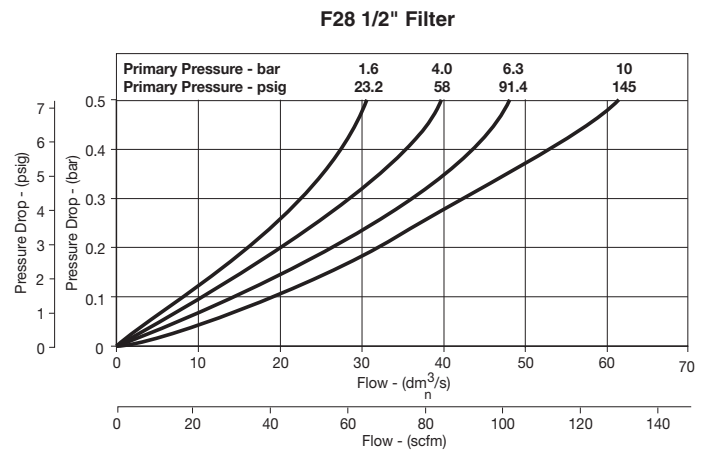
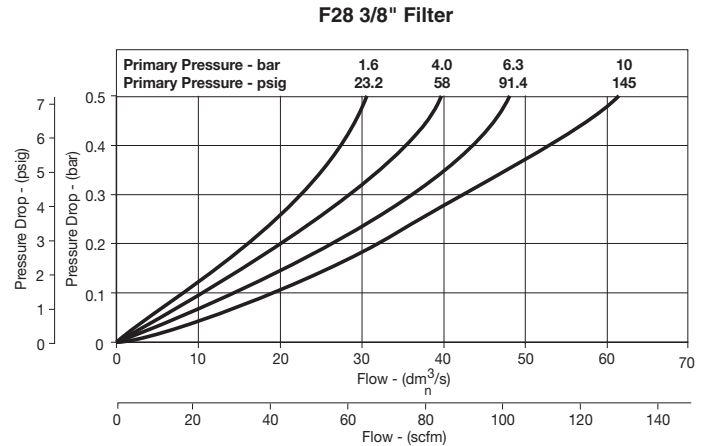

Ordering Information

Model Type	Port Size	Plastic Bowl / Bowl Guard	Metal Bowl / Sight Gauge
Manual Drain	3/8	F28-03-SK00B	F28-03-SL00B
	1/2	F28-04-SK00B	F28-04-SL00B
	3/4	F28-06-SK00B	F28-06-SL00B
Automatic Drain	3/8	F28-03-SG00B	F28-03-SH00B
	1/2	F28-04-SG00B	F28-04-SH00B
	3/4	F28-06-SG00B	F28-06-SH00B

Options - To order an option supplied with the unit model, add the appropriate coded suffix letter in the designated position of the model number.

Particulate Filter F90

= "Most Popular"



Symbols

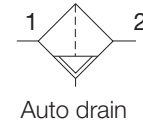
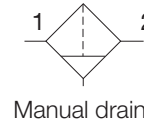

- Integral 3/4" or 1" ports (NPT & BSPP)
- High efficiency particulate element as standard
- Excellent water removal efficiency
- Robust but lightweight aluminum construction
- Low temperature -40° with combined manual / semi-auto drain as standard

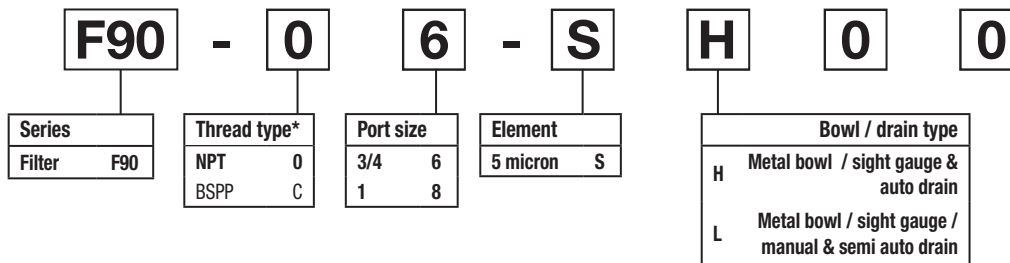

*Note: For 1-1/2" ported unit, please order P3YKA*BCP port block kit separately.
Bold items are most common.

Ordering information

Port size	Description	Flow [‡] scfm	Max. bar (psig)	Min temp °C (°F)	Max temp °C (°F)	Bowl capacity cm ³ (oz)	Height mm (inches)	Width mm (inches)	Depth mm (inches)	Weight kg (lb)	Part number [†]
3/4"	Combined manual / semi auto drain	170	17.5 (254)	-40 (-40)	60 (140)	130 (4.4)	244 (9.6)	90 (3.5)	94 (3.7)	0.9 (1.98)	F90-06-SL00
3/4"	Auto drain	170	17.5 (254)	-10 (14)	60 (140)	130 (4.4)	244 (9.6)	90 (3.5)	94 (3.7)	0.9 (1.98)	F90-06-SH00
1"	Combined manual / semi auto drain	170	17.5 (254)	-40 (-40)	60 (140)	130 (4.4)	244 (9.6)	90 (3.5)	94 (3.7)	0.9 (1.98)	F90-08-SL00
1"	Auto drain	170	17.5 (254)	-10 (14)	60 (140)	130 (4.4)	244 (9.6)	90 (3.5)	94 (3.7)	0.9 (1.98)	F90-08-SH00

[†] Standard part numbers shown in bold. For other models refer to Options chart above.

[‡] Flow with 6.3 bar (91.4 psig) inlet pressure and 0.5 (7.3 psig) pressure drop.

Specifications

Fluid	Compressed air	
Maximum inlet pressure*	17.5 bar (254 psig)	
Temperature range*:		
Auto drain	-10°C to 60°C (14°F to 140°F)	
Combined drain	-40°C to 60°C (-40°F to 140°F)	
Particle removal	5 micron	
Air quality	Within ISO 8573-1: 1991 Class 3 and 5 (particulates) Within ISO 8573-1: 2001 Class 6 and 7 (particulates)	
Typical flow 5 micron element 6.3 bar (91.4 psig) inlet pressure and 0.5 bar (7.3 psig) pressure drop	1" port 170 scfm	
Manual / semi-auto drain	Closed at 0.8 bar (11.6 psig) G1/8 thread male	
Auto drain bowl pressure to close drain	0.8 bar (11.6 psig)	
Operating range manual override facility	0.8 bar (11.6 psig) to 17.5 bar (254 psig)	
Bowl capacity	130 cm ³ (4.4 US oz)	

* Air supply must be dry enough to avoid ice formation at temperatures below 2°C (35.6°F).

Dimensions mm (inches)

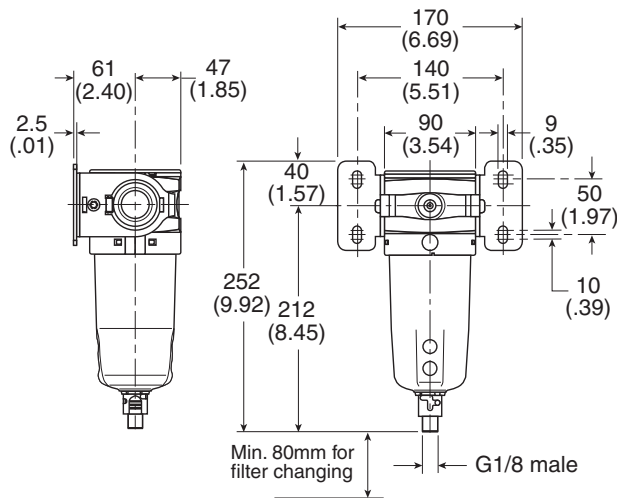

Service kits

- 5 micron element kit.....P3YKA00ESE
- 40 micron element kit..... P3YKA00ESG
- Bowl kit with combined manual /
semi auto drain..... P3YKA00BSC
- Bowl kit with auto drainP3YKA00BSA

Material specifications

Body	Aluminum	
Sight glass	Polypropylene	
Body cover	ABS	
Element	Sintered P.E.	
Seals	Nitrile NBR	
Drains	Manual / semi-auto:	Acetal
	Automatic:	PA / Ø 10mm brass connection

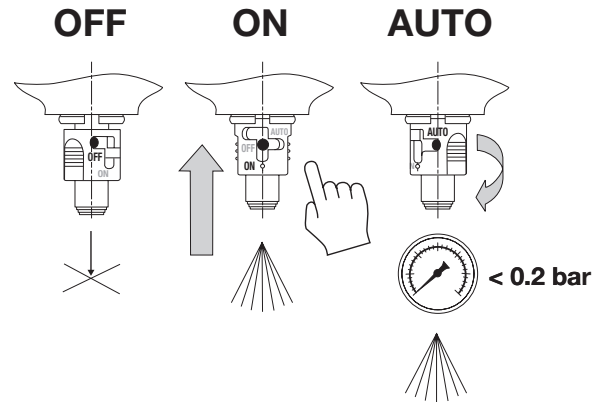

Flow characteristics

(3/4") Filter

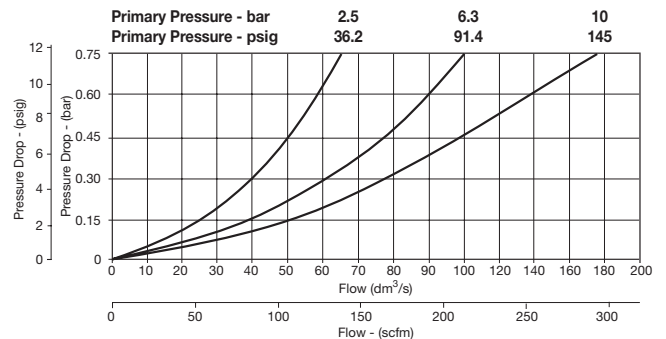

(1") Filter

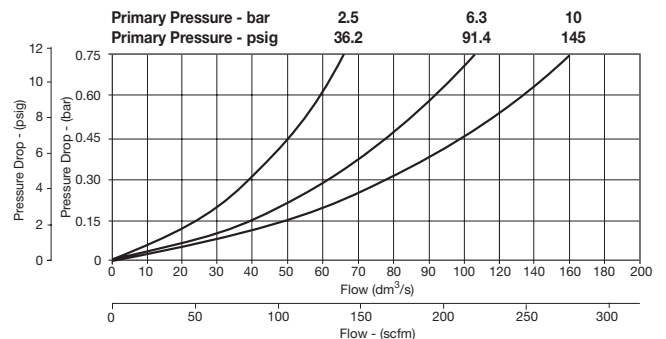

Notes

Coalescing (Oil Removal) Numbering System

 = "Most Popular"

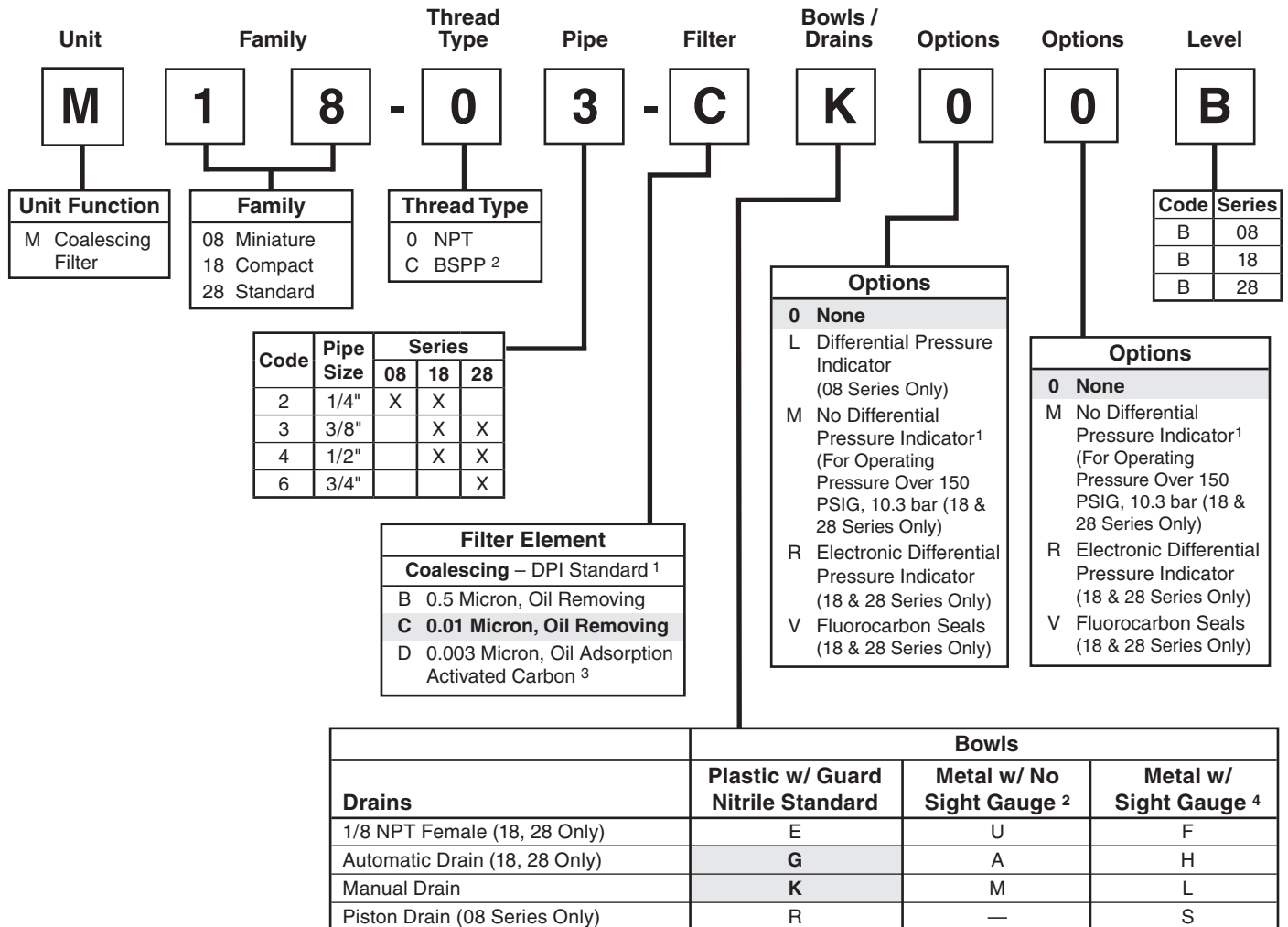

¹ "M" Option not available on 08 Series.

² ISO, R228 (G Series)

³ Only C, D, K, and L bowl / drain configurations available.

⁴ M08 filter has an all metal bowl (no sight gauge).

"M" Series Coalescing Filters, with Type "B" 0.5 micron elements: All Wilkerson Type "M" Oil Removal (Coalescing) Filters with Type "B" 0.5 micron elements **exceed ISO Class 2** for maximum particle size and concentration of solid contaminants, and exceed Class 3 on maximum oil content (ppm/wt).

"M" Series Coalescing Filters, with Type "C" 0.01 micron elements: All Wilkerson Type "M" Oil Removal (Coalescing) Filters with Type "C" 0.01 micron elements **exceed ISO Class 1** for maximum particle size and concentration of solid contaminants, and exceed Class 1 on maximum oil content (ppm/wt).

"M" Series Adsorption Filters, with Type "D" activated carbon elements: All Wilkerson Type "M" adsorption filters with Type "D" 0.003 micron activated carbon elements **exceed ISO Class 1** on maximum oil content (ppm/wt).

NOTE: All classes above refer to International Standards Organization (ISO) standard 8573-1, pertaining to maximum particle size and concentration of solid contaminants, and maximum oil content.

Note: When selecting from the options columns, please enter letters in alphabetical order for positions 7, 8, and 9. For example:

M 1 8 - 0 3 - C K 0 0 B

Coalescing Filter M08

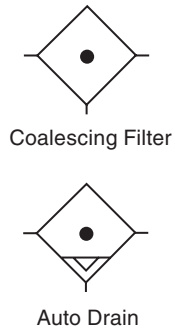

Features

- High-efficiency Removal of Water, Oil Aerosols, and Solid Particulate Contaminants Down to 0.01 ppm / wt with Minimum Pressure Drop
- Modern Design and Appearance
- Light Weight
- High Flow Capacity
- Bowl Guard
- Quick-disconnect Bowl

Specifications

Flow Capacity*		
1.0 Micron Coalescing		12.0 SCFM (5.5 dm ³ /s, ANR)
0.01 Micron Coalescing		7.5 SCFM (3.6 dm ³ /s, ANR)
Activated Carbon Adsorber		12.7 SCFM (6 dm ³ /s, ANR)
Maximum Supply Pressure		
Plastic Bowl		150 PSIG (10 bar)
Metal Bowl w/ DPI		150 PSIG (10 bar)
Metal Bowl w/o DPI		250 PSIG (17 bar)
Operating Temperature		
Plastic Bowl	14° to 125°F (-10° to 52°C)	
Metal Bowl	14° to 150°F (-10° to 65.5°C)	
Port Size		NPT / BSPP-G 1/4
Bowl Capacity		0.4 oz
Standard Filtration Micron		(B) .5, (C) 0.01 (D) 0.003 ppm wt**
Weight		0.24 lb. (0.11 kg)

* Inlet pressure 91.3 PSIG (6.3 bar). Pressure drop 3 PSIG (0.2 bar).

** Filtration temperature of 70°F (21°C) @ 100 PSIG (6.9 bar) with typical compressor lubricating oil and protected by Type C filter.

“M” Series Coalescing Filters, with Type “B” 0.5 micron elements: All Wilkerson Type “M” Oil Removal (Coalescing) Filters with Type “B” 0.5 micron elements exceed ISO Class 2 for maximum particle size and concentration of solid contaminants, and exceed Class 3 on maximum oil content (ppm/wt).

“M” Series Coalescing Filters, with Type “C” 0.01 micron elements: All Wilkerson Type “M” Oil Removal (Coalescing) Filters with Type “C” 0.01 micron elements exceed ISO Class 1 for maximum particle size and concentration of solid contaminants, and exceed Class 1 on maximum oil content (ppm/wt).

“M” Series Adsorption Filters, with Type “D” 0.003 micron activated carbon elements: All Wilkerson Type “M” adsorption filters with Type “D” 0.003 micron activated carbon elements exceed ISO Class 1 on maximum oil content (ppm/wt).

Materials of Construction

Body	Aluminum	
Body Cap	ABS	
Bowl	Plastic Bowl	Polycarbonate
	Metal Bowl	Aluminum
Filter Element	Type “B”, “C”	Borosilicate Cloth
	Type “D”	Activated Carbon
Seals	Nitrile	

Notes: To optimize the life of the coalescing element, it is advisable to install a pre-filter with a 5 micron element upstream of the coalescing filter.

To optimize the life of the adsorber element, it is advisable to install a coalescing 0.01 micron filter upstream of the adsorber filter.

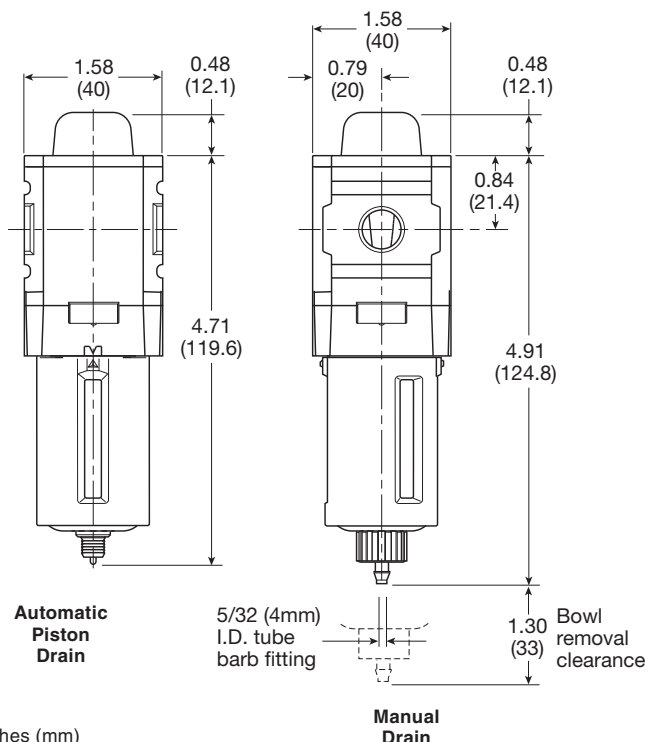

Inches (mm)

 = "Most Popular"

Replacement Bowl Kits

- Metal Bowl, Manual Drain.....GRP-96-714
- Plastic Bowl / Bowl Guard, Manual Drain.....GRP-96-712

Replacement Element Kits

- Type "B", 0.5 Micron..... MSP-96-732
- Type "C", 0.01 Micron..... MTP-96-649
- Type "D", 0.003 Micron, Activated Carbon MXP-96-222

Accessories

- Automatic Piston DrainGRP-96-716
- Wall Mounting Bracket –
- C-Type GPA-97-010
- T-Type GPA-96-737

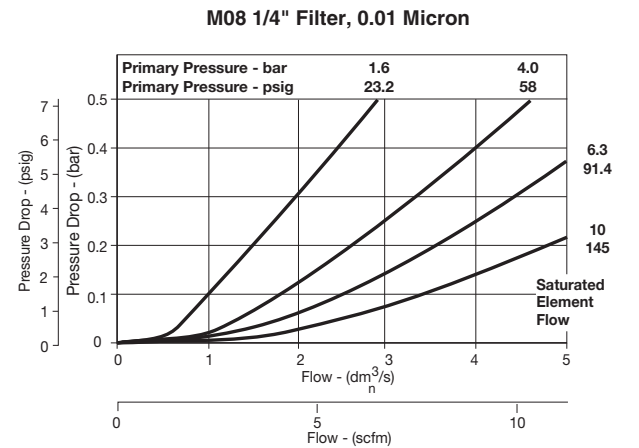
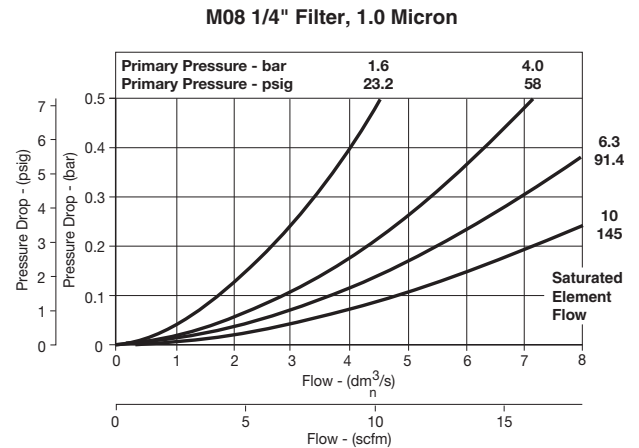

Ordering Information

Model Type	Port Size	Plastic Bowl / Bowl Guard / C Element	Plastic Bowl / Bowl Guard / B Element	Plastic Bowl / Bowl Guard / D Element	Metal Bowl / C Element	Metal Bowl / B Element	Metal Bowl / D Element
Manual Drain	1/4	M08-02-CK00B	M08-02-BK00B	M08-02-DK00B	M08-02-CL00B	M08-02-BL00B	M08-02-DL00B
Automatic Piston Drain	1/4	M08-02-CR00B	M08-02-BR00B	M08-02-DR00B	M08-02-CS00B	M08-02-BS00B	M08-02-DS00B

Options - To order an option supplied with the unit model, add the appropriate coded suffix letter in the designated position of the model number.

Coalescing Filter M18

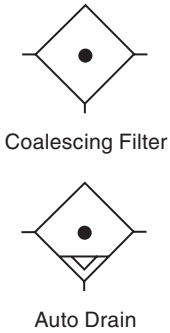

Features

- High-efficiency Removal of Water, Oil Aerosols, and Solid Particulate Contaminants Down to 0.01 ppm / wt with Minimum Pressure Drop
- Modern Design and Appearance
- Light Weight
- High Flow Capacity
- Bowl Guard
- Quick-disconnect Bowl

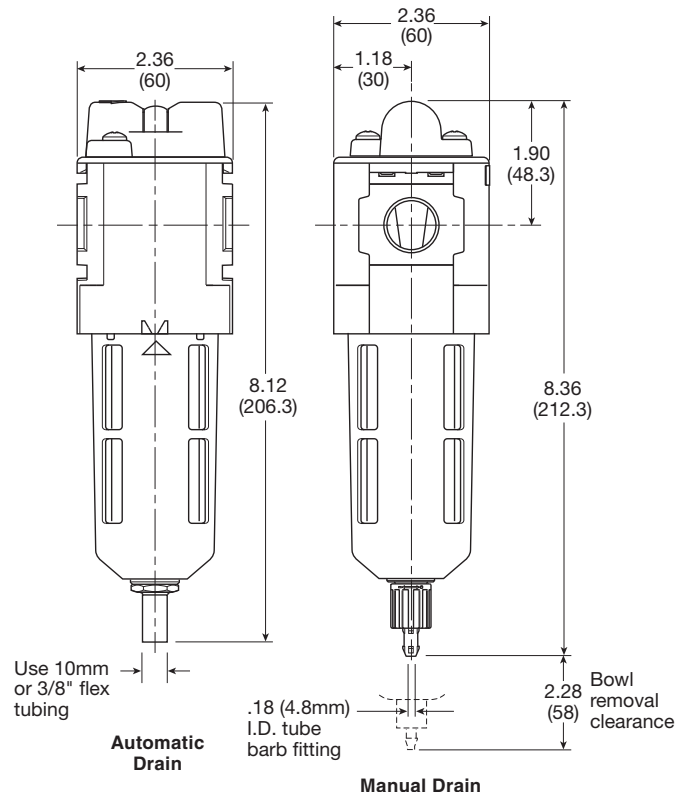

Inches (mm)

Specifications

Flow Capacity*		
1.0 Micron Coalescing		53 SCFM (25 dm ³ /s, ANR)
0.01 Micron Coalescing		36 SCFM (17 dm ³ /s, ANR)
Activated Carbon Adsorber		85 SCFM (40 dm ³ /s, ANR)
Maximum Supply Pressure	Plastic Bowl	150 PSIG (10 bar) [†]
	Metal Bowl w/ DPI	150 PSIG (10 bar) [†]
	Metal Bowl w/o DPI	250 PSIG (17 bar) [†]
Operating Temperature	Plastic Bowl	-13° to 125°F (-25° to 52°C)
	Metal Bowl	-13° to 150°F (-25° to 65.5°C)
Port Size	NPT / BSPP-G	1/4, 3/8, 1/2
Bowl Capacity		1.72 oz
Standard Filtration	Micron	(B) 0.5, (C) 0.01
		(D) 0.003 ppm wt**
Weight		0.71 lb (0.32 kg)

* Inlet pressure 91.3 PSIG (6.3 bar). Pressure drop 3 PSIG (0.2 bar).

** Filtration temperature of 70°F (21°C) @ 100 PSIG (6.9 bar) with typical compressor lubricating oil and protected by Type C filter.

† Without pressure indicator — max. supply pressure for metal bowl version is 250 PSIG (17.2 bar).

“M” Series Coalescing Filters, with Type “B” 0.5 micron elements: All Wilkerson Type “M” Oil Removal (Coalescing) Filters with Type “B” 0.5 micron elements **exceed ISO Class 2** for maximum particle size and concentration of solid contaminants, and exceed Class 3 on maximum oil content (ppm/wt).

“M” Series Coalescing Filters, with Type “C” 0.01 micron elements: All Wilkerson Type “M” Oil Removal (Coalescing) Filters with Type “C” 0.01 micron elements **exceed ISO Class 1** for maximum particle size and concentration of solid contaminants, and exceed Class 1 on maximum oil content (ppm/wt).

“M” Series Adsorption Filters, with Type “D” 0.003 micron activated carbon elements: All Wilkerson Type “M” adsorption filters with Type “D” 0.003 micron activated carbon elements **exceed ISO Class 1** on maximum oil content (ppm/wt).

Materials of Construction

Body	Aluminum	
Body Cap	ABS	
Bowl	Plastic Bowl	Polycarbonate
	Metal Bowl	Aluminum
Filter Element	Type “B”, “C”	Borosilicate Cloth
	Type “D”	Activated Carbon
Seals	Nitrile	
Sight Gauge	Metal Bowl	Polyamide (Nylon)

Notes: To optimize the life of the coalescing element, it is advisable to install a pre-filter with a 5 micron element upstream of the coalescing filter.

To optimize the life of the adsorber element, it is advisable to install a coalescing 0.01 micron filter upstream of the adsorber filter.

= "Most Popular"

Replacement Bowl Kits

- Metal Bowl with Sight Gauge,
Automatic Float Drain..... GRP-96-637
- Metal Bowl with Sight Gauge, Manual Drain..... GRP-96-636
- Plastic Bowl –
Bowl Guard, Auto Drain GRP-96-635
- Bowl Guard, Manual Drain..... GRP-96-634

Replacement Element Kits

- Type "B", 0.5 Micron..... MSP-96-647
- Type "C", 0.01 Micron..... MTP-96-646
- Type "D", 0.003 Micron Activated Carbon MXP-96-650

Accessories

- Automatic Drain –
Fluorocarbon GRP-95-981
- Nitrile GRP-95-973
- DPI Replacement Kit..... DP8-01-000
- Electronic DPI Conversion Kit..... GRP-96-823
(Converts visual DPI to electronic DPI)
- Electronic DPI Replacement Kit GRP-96-824
- Manual Drain..... GRP-96-685
- Sight Gauge Kit..... GRP-96-825
- Wall Mounting Bracket –
L-Type GPA-96-604
- T-Type GPA-96-602

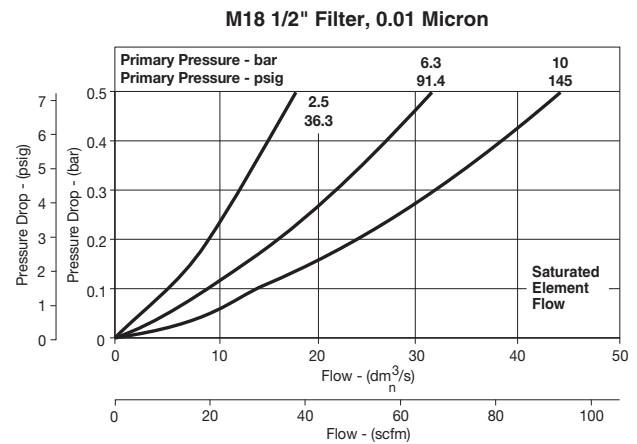
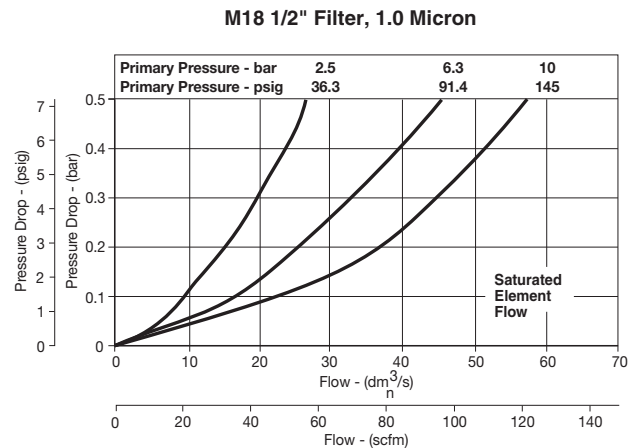

Ordering Information

Model Type	Port Size	Plastic Bowl / Bowl Guard / C Element	Plastic Bowl / Bowl Guard / B Element	Plastic Bowl / Bowl Guard / D Element	Metal Bowl / Sight Gauge / C Element	Metal Bowl / Sight Gauge / B Element	Metal Bowl / Sight Gauge / D Element
Manual Drain	1/4	M18-02-CK00B	M18-02-BK00B	M18-02-DK00B	M18-02-CL00B	M18-02-BL00B	M18-02-DL00B
	3/8	M18-03-CK00B	M18-03-BK00B	M18-03-DK00B	M18-03-CL00B	M18-03-BL00B	M18-03-DL00B
	1/2	M18-04-CK00B	M18-04-BK00B	M18-04-DK00B	M18-04-CL00B	M18-04-BL00B	M18-04-DL00B
Automatic Drain	1/4	M18-02-CG00B	M18-02-BG00B	N/A	M18-02-CH00B	M18-02-BH00B	N/A
	3/8	M18-03-CG00B	M18-03-BG00B	N/A	M18-03-CH00B	M18-03-BH00B	N/A
	1/2	M18-04-CG00B	M18-04-BG00B	N/A	M18-04-CH00B	M18-04-BH00B	N/A

Options - To order an option supplied with the unit model, add the appropriate coded suffix letter in the designated position of the model number.

Coalescing Filter M28

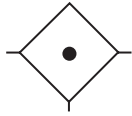

Coalescing Filter

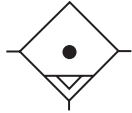

Auto Drain



Features

- High-efficiency Removal of Water, Oil Aerosols, and Solid Particulate Contaminants Down to 0.01 ppm / wt with Minimum Pressure Drop
- Modern Design and Appearance
- Light Weight
- High Flow Capacity
- Bowl Guard
- Quick-disconnect Bowl

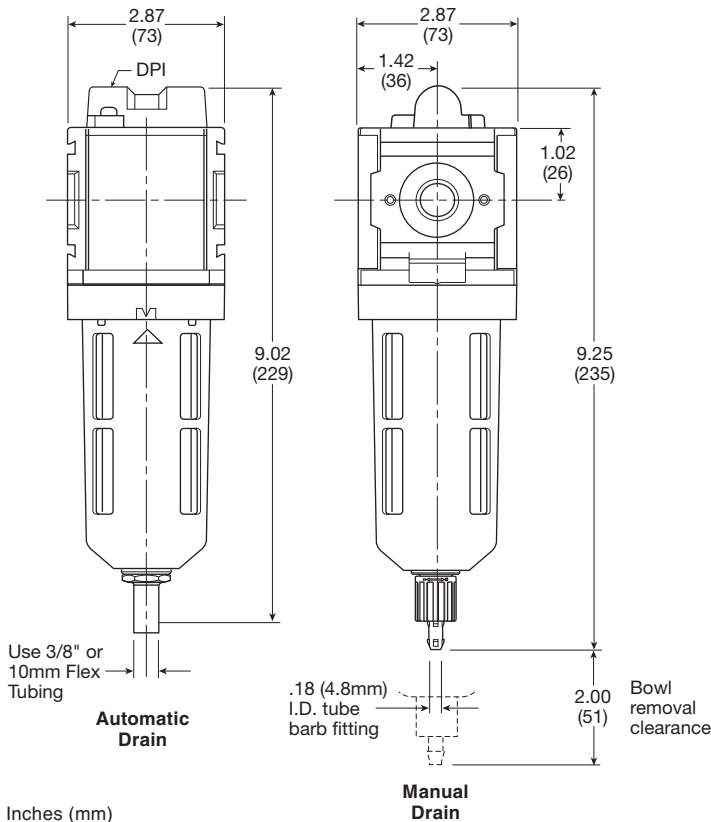

Specifications

Flow Capacity*		
1.0 Micron Coalescing		68 SCFM (32 dm ³ /s, ANR)
0.01 Micron Coalescing		42 SCFM (20 dm ³ /s, ANR)
Activated Carbon Adsorber		72 SCFM (34 dm ³ /s, ANR)
Maximum Supply Pressure	Plastic Bowl	150 PSIG (10.3 bar)†
	Metal Bowl	150 PSIG (10.3 bar)†
Operating Temperature	Plastic Bowl	-13° to 125°F (-25° to 52°C)
	Metal Bowl	-13° to 150°F (-25° to 65.5°C)
Port Size	NPT / BSPP-G	3/8, 1/2, 3/4
Bowl Capacity	2.87 oz	
Standard Filtration	Micron	(B) 0.5, (C) 0.01
		(D) 0.003 ppm wt**
	Weight	1.10 lb. (0.5 kg)

* Inlet pressure 91.3 PSIG (6.3 bar). Pressure drop 3 PSIG (0.2 bar).

** Filtration temperature of 70°F (21°C) @ 100 PSIG (6.9 bar) with typical compressor lubricating oil and protected by Type C filter.

† Without pressure indicator — max. supply pressure for metal bowl version is 250 PSIG (17.2 bar)

“M” Series Coalescing Filters, with Type “B” 0.5 micron elements: All Wilkerson Type “M” Oil Removal (Coalescing) Filters with Type “B” 0.5 micron elements **exceed ISO Class 2** for maximum particle size and concentration of solid contaminants, and exceed Class 3 on maximum oil content (ppm/wt).

“M” Series Coalescing Filters, with Type “C” 0.01 micron elements: All Wilkerson Type “M” Oil Removal (Coalescing) Filters with Type “C” 0.01 micron elements **exceed ISO Class 1** for maximum particle size and concentration of solid contaminants, and exceed Class 1 on maximum oil content (ppm/wt).

“M” Series Adsorption Filters, with Type “D” 0.003 micron activated carbon elements: All Wilkerson Type “M” adsorption filters with Type “D” 0.003 micron activated carbon elements **exceed ISO Class 1** on maximum oil content (ppm/wt).

Materials of Construction

Body	Aluminum	
Body Cap	ABS	
Bowls	Plastic Bowl	Polycarbonate
	Metal Bowl	Aluminum
Filter Element	Type “B”, “C”	Borosilicate Cloth
	Type “D”	Activated Carbon
Seals	Nitrile	
Sight Gauge	Metal Bowl	Polyamide (Nylon)

Notes: To optimize the life of the coalescing element, it is advisable to install a pre-filter with a 5 micron element upstream of the coalescing filter.

To optimize the life of the adsorber element, it is advisable to install a coalescing 0.01 micron filter upstream of the adsorber filter.

 = "Most Popular"

Replacement Bowl Kits

- Metal Bowl with Sight Gauge,
Automatic Float Drain..... GRP-96-645
- Metal Bowl with Sight Gauge, Manual Drain..... GRP-96-644
- Plastic Bowl –
Bowl Guard, Auto Drain GRP-96-643
- Bowl Guard, Manual Drain GRP-96-642

Replacement Element Kits

- Type "B", 0.5 Micron..... MSP-96-649
- Type "C", 0.01 Micron..... MTP-96-648
- Type "D", 0.003 Micron Activated Carbon MXP-96-651

Accessories

- Automatic Drain –
Fluorocarbon GRP-95-981
- Nitrile GRP-95-973
- DPI Replacement Kit..... DP8-01-000
- Electronic DPI Conversion Kit..... GRP-96-823
(Converts visual DPI to electronic DPI)
- Electronic DPI Replacement Kit GRP-96-824
- Manual Drain..... GRP-96-685
- Sight Gauge Kit..... GRP-96-825
- Wall Mounting Bracket–
L-Type GPA-96-605
- T-Type GPA-96-602

M28 3/4" Filter, 1.0 Micron

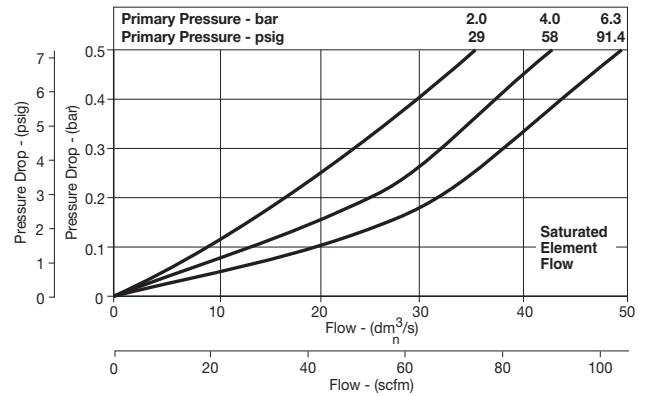

M28 3/4" Filter, 0.01 Micron

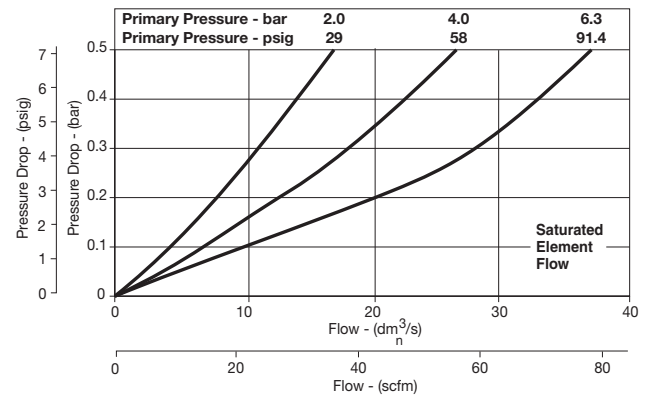

Ordering Information

Model Type	Port Size	Plastic Bowl / Bowl Guard / C Element	Plastic Bowl / Bowl Guard / B Element	Plastic Bowl / Bowl Guard / D Element	Metal Bowl / Sight Gauge / C Element	Metal Bowl / Sight Gauge / B Element	Metal Bowl / Sight Gauge / D Element
Manual Drain	3/8	M28-03-CK00B	M28-03-BK00B	M28-03-DK00B	M28-03-CL00B	M28-03-BL00B	M28-03-DL00B
	1/2	M28-04-CK00B	M28-04-BK00B	M28-04-DK00B	M28-04-CL00B	M28-04-BL00B	M28-04-DL00B
	3/4	M28-06-CK00B	M28-06-BK00B	M28-06-DK00B	M28-06-CL00B	M28-06-BL00B	M28-06-DL00B
Automatic Drain	3/8	M28-03-CG00B	M28-03-BG00B	N/A	M28-03-CH00B	M28-03-BH00B	N/A
	1/2	M28-04-CG00B	M28-04-BG00B	N/A	M28-04-CH00B	M28-04-BH00B	N/A
	3/4	M28-06-CG00B	M28-06-BG00B	N/A	M28-06-CH00B	M28-06-BH00B	N/A

Options - To order an option supplied with the unit model, add the appropriate coded suffix letter in the designated position of the model number.

Coalescing Filter M90

 = "Most Popular"



- Extended high efficiency filter element provides greater filtration surface area.
- Integral 3/4" or 1" ports (BSPP & NPT)
- Removes liquid aerosols and sub micron particles
- Oil free air for critical applications, such as air gauging, pneumatic instrumentation and control
- Adsorber activated carbon element removes oil vapors and most hydrocarbons
- Robust but lightweight aluminum construction

Notes: To optimize the life of the coalescing element, it is advisable to install a F90 pre-filter with a 5 micron element upstream of the coalescing filter.

To optimize the life of the adsorber element, it is advisable to install a 90 Series coalescing 0.01 micron filter upstream of the adsorber filter.

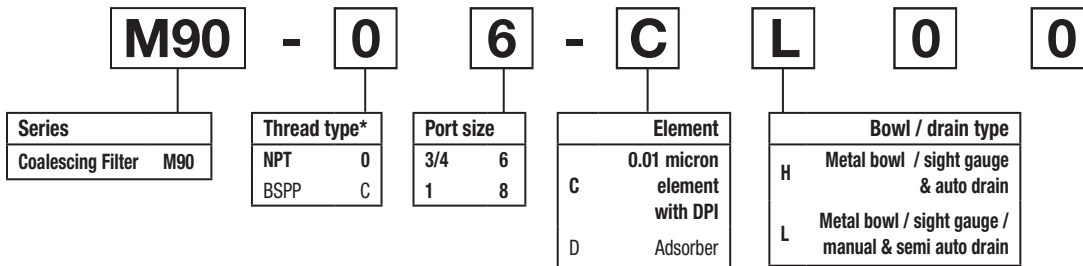

*Note: For 1-1/2" ported unit, please order P3YKA*BCP port block kit separately.
Bold items are most common.

Ordering information

Port size	Description	Flow [‡] scfm	Max. bar (psig)	Min temp °C (°F)	Max temp °C (°F)	Bowl capacity cm ³ (oz)	Height mm (inches)	Width mm (inches)	Depth mm (inches)	Weight kg (lb)	Part number [†]
3/4"	Coalescing filter 0.01 micron, combined manual / semi auto drain	275	17.5 (254)	-10 (14)	60 (140)	130 (4.4)	340 (13.4)	90 (3.5)	94 (3.7)	1.6 (3.5)	M90-06-CL00
3/4"	Coalescing filter 0.01 micron, auto drain	275	17.5 (254)	-10 (14)	60 (140)	130 (4.4)	340 (13.4)	90 (3.5)	94 (3.7)	1.6 (3.5)	M90-06-CH00
1"	Coalescing filter 0.01 micron, combined manual / semi auto drain	307	17.5 (254)	-10 (14)	60 (140)	130 (4.4)	340 (13.4)	90 (3.5)	94 (3.7)	1.6 (3.5)	M90-08-CL00
1"	Coalescing filter 0.01 micron, auto drain	307	17.5 (254)	-10 (14)	60 (140)	130 (4.4)	340 (13.4)	90 (3.5)	94 (3.7)	1.6 (3.5)	M90-08-CH00

[†] Standard part numbers shown in bold. For other models refer to Options chart above.

[‡] Flow with 6.3 bar (91.4 psig) inlet pressure and 0.5 (7.3 psig) pressure drop.

Specifications

Fluid	Compressed air
Maximum inlet pressure*	17.5 bar (254 psig)
Temperature range*	-10°C to 60°C (14°F to 140°F)
Media specifications (Coalescer):	
Coalescing efficiency	99.97% (0.3 to 0.6 micron particles)
Max. oil carryover	0.008 mg/m ³
Typical flow element @	0.01 micron element
6.3 bar (91.4 psig) inlet pressure and	1" port
0.5 bar (7.3 psig) pressure drop	307 scfm
Media specifications (Adsorber):	
Max. oil carryover (PPM w/w)	0.008 mg/m ³
Manual / semi-auto drain	Closed at 0.8 bar (11.6 psig) G1/8 thread male
Auto drain bowl pressure to close drain	0.8 bar (11.6 psig)
Operating range	0.8 bar (11.6 psig) to manual override facility
Bowl capacity	130 cm ³ (4.4 US oz)

* Air supply must be dry enough to avoid ice formation at temperatures below 2°C (35.6°F).

Material specifications

Body	Aluminum
Sight glass	Polypropylene
Filter cover	ABS
Coalescing element	Borosilicate & nano fibers
Top & bottom end cap (Coalescing)	Aluminum
Adsorber element	Activated carbon
Top & bottom end cap (Adsorber)	Glass filled nylon
Support cylinders	Grade 430 stainless steel
Support media	Polypropylene
Anti re-entrainment barrier	Polyester
Encapsulate	Epoxy resin / hardener
Seals	Nitrile NBR
Drains	Manual / semi-auto: Acetal Automatic: PA / Ø 10mm brass connection
Differential pressure indicator	
Body	Acetal
Internal parts	Acetal
Spring	Stainless steel
Seals	Nitrile NBR
Support plate	ABS
Screws	Steel / zinc plated

Dimensions mm (inches)

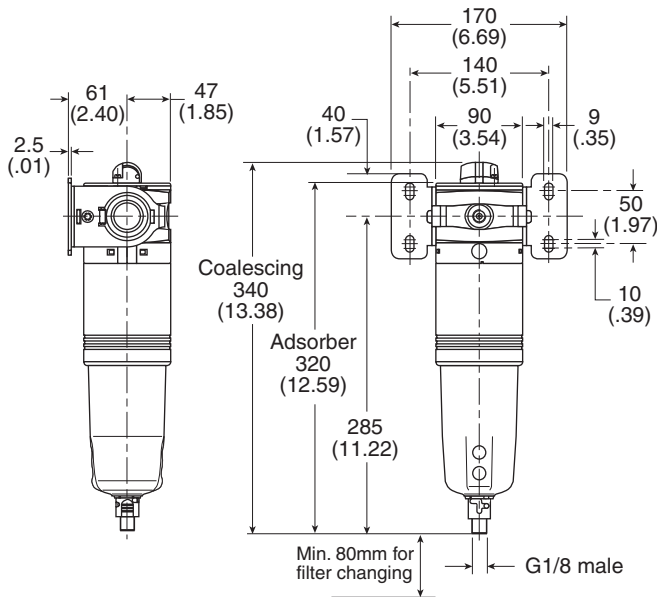

Service kits

- 0.01 micron element kit.....P3YKA00ESC
- Adsorber element kit.....P3YKA00ESA
- Bowl kit with combined manual / semi auto drain..... P3YKA00BSC
- Bowl kit with auto drain.....P3YKA00BSA
- Differential pressure indicator kit..... P3YKA00RQ

Flow characteristics

(3/4") 0.01 Micron Coalescing Filter Saturated

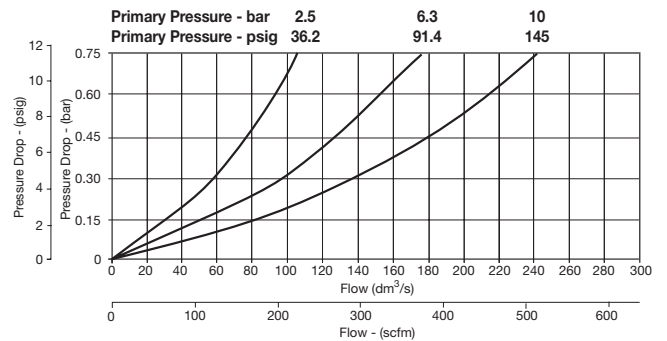

(1") 0.01 Micron Coalescing Filter Saturated

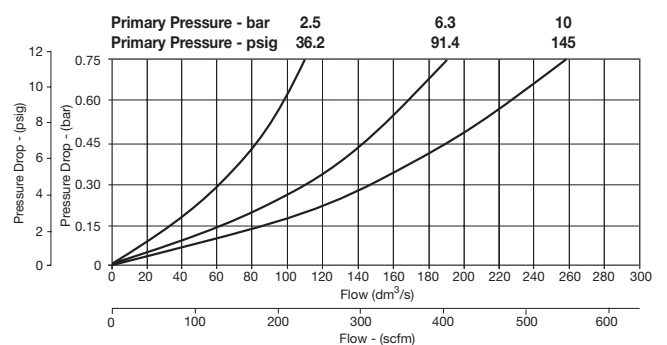

Notes

Afterfilter Numbering System

 = "Most Popular"

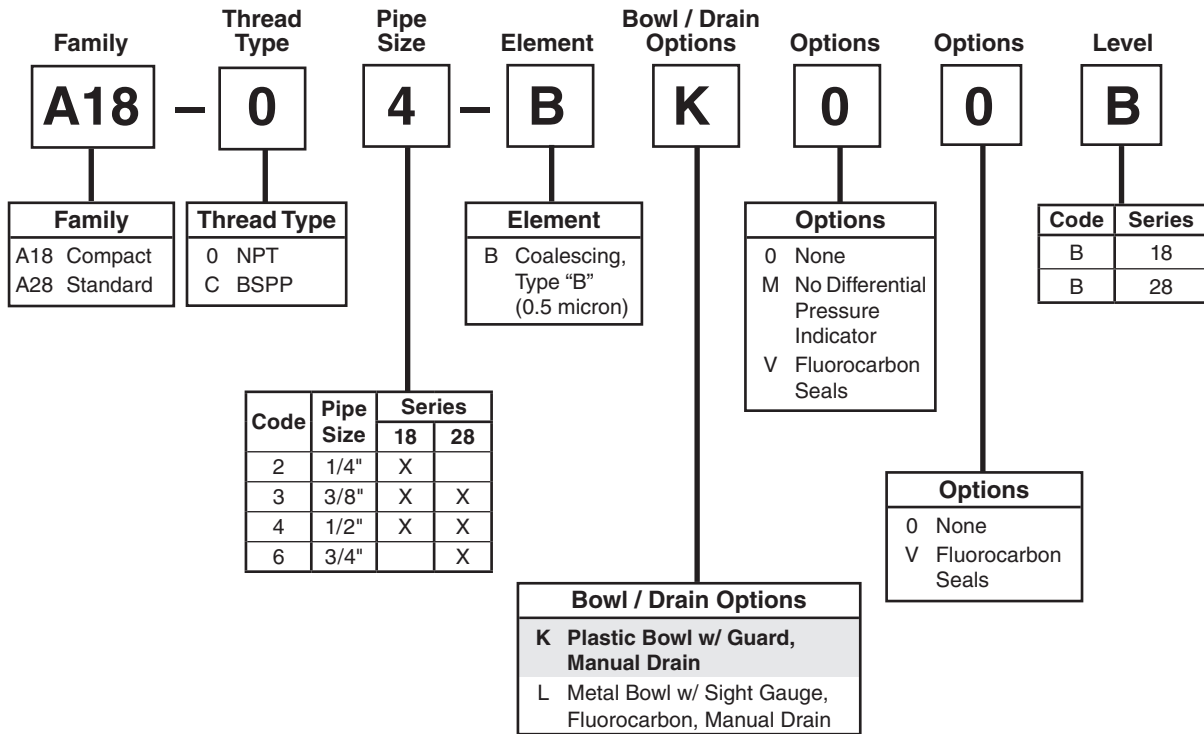

NOTE: All classes above refer to International Standards Organization (ISO) standard 8573-1, pertaining to maximum particle size and concentration of solid contaminants, and maximum oil content.

If more than one option is desired, arrange them in alphabetical order in positions 6, 7, and 8.

Afterfilter A18

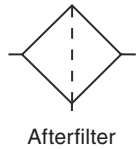

= "Most Popular"

Specifications

Flow Capacity*	1/4	50 SCFM (23.6 dm ³ /s)
	3/8	60 SCFM (28.3 dm ³ /s)
	1/2	67 SCFM (31.6 dm ³ /s)
Maximum Supply Pressure	Plastic Bowl	150 PSIG (10.3 bar)
	Metal Bowl	250 PSIG (17.2 bar)
Operating Temperature	Plastic Bowl	-13° to 125°F (-25° to 52°C)
	Metal Bowl	-13° to 150°F (-25° to 65.5°C)
Port Size	NPT / BSPP-G	1/4, 3/8, 1/2
Standard Filtration	0.5 Micron	
Weight	0.71 lb. (0.32 kg)	

* Inlet pressure 91.3 PSIG (6.3 bar). Pressure drop 3 PSID (0.2 bar).

"A18" Series Afterfilters, with Type "B" 0.5 micron elements:
 All Wilkerson Type "AF" Afterfilters with Type "B" 0.5 micron elements **exceed ISO** Class 2 for maximum particle size and concentration of solid contaminants, and **exceed** Class 3 on maximum oil content (ppm/wt).

Features

- Modern Design and Appearance
- 0.5 Micron Element
- Light Weight
- High Flow Capacity with Minimal Pressure Drop

Materials of Construction

Body	Aluminum	
Body Cap	ABS	
Bowls	Plastic Bowl	Polycarbonate
	Metal Bowl	Aluminum
Filter Element	Type "B"	Borosilicate Fiber
Seals	Nitrile	
Sight Gauge	Metal Bowl	Nylon

Replacement Bowl Kits

Metal Bowl with Sight Gauge, Manual Drain	GRP-96-636
Plastic Bowl / Bowl Guard, Manual Drain	GRP-96-634
Plastic Bowl, Plastic Guard, No Drain	GRP-96-638

Replacement Element Kit

Type "B", 0.5 Micron.....	MSP-96-647
---------------------------	------------

Accessories

Wall Mounting Bracket –	
L-Type	GPA-96-604
T-Type	GPA-96-602

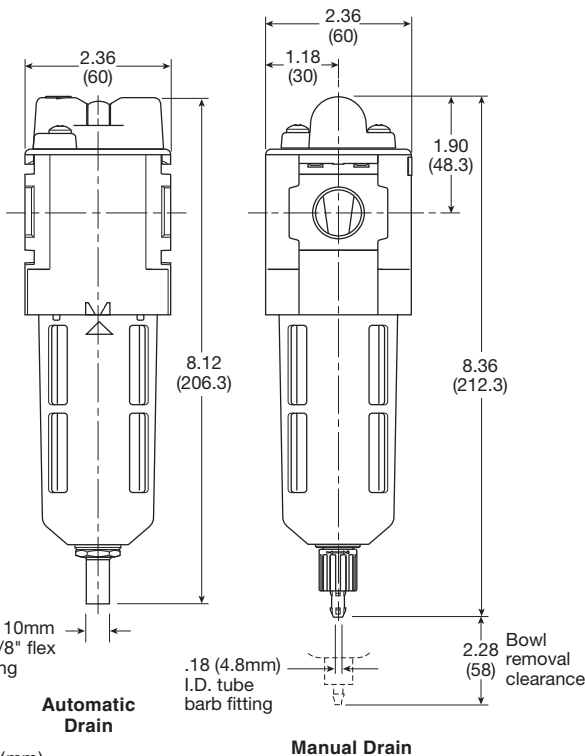

Inches (mm)

Ordering Information

Model Type	Port Size	Polycarbonate Bowl / Bowl Guard / "B" Element	Metal Bowl / Sight Gauge / "B" Element
Type "B" Element is Standard (Manual Drain)	1/4	A18-02-BK00B	A18-02-BL00B
	3/8	A18-03-BK00B	A18-03-BL00B
	1/2	A18-04-BK00B	A18-04-BL00B

Options - To order an option supplied with the unit model, add the appropriate coded suffix letter in the designated position of the model number.

Afterfilter A28

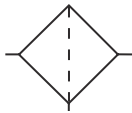

Afterfilter



= "Most Popular"

Specifications

Flow Capacity*	3/8	82 SCFM (38.7 dm ³ /s)
	1/2	90 SCFM (42.5 dm ³ /s)
	3/4	98 SCFM (46.3 dm ³ /s)
Maximum Supply Pressure	Plastic Bowl	150 PSIG (10.3 bar)
	Metal Bowl	250 PSIG (17.2 bar)
Operating Temperature	Plastic Bowl	-13° to 125°F (-25° to 52°C)
	Metal Bowl	-13° to 150°F (-25° to 65.5°C)
Port Size	NPT / BSPP-G	3/8, 1/2, 3/4
Standard Filtration	0.5 Micron	
Weight	1.01 lb. (0.46 kg)	

* Inlet pressure 91.3 PSIG (6.3 bar). Pressure drop 3 PSID (0.2 bar).

"A28" Series Afterfilters, with Type "B" 0.5 micron elements:
All Wilkerson Type "AF" Afterfilters with Type "B" 0.5 micron elements **exceed ISO** Class 2 for maximum particle size and concentration of solid contaminants, and **exceed** Class 3 on maximum oil content (ppm/wt).

Features

- Modern Design and Appearance
- 0.5 Micron Element
- Light Weight
- High Flow Capacity with Minimal Pressure Drop
- Bowl Guard
- Quick-Disconnect Bowl

Materials of Construction

Body	Aluminum	
Body Cap	ABS	
Bowls	Plastic Bowl	Polycarbonate
	Metal Bowl	Aluminum
Filter Element	Type "B"	Borosilicate Fiber
Seals	Nitrile	
Sight Gauge	Metal Bowl	Nylon

Replacement Bowl Kits

Metal Bowl with Sight Gauge, Manual Drain	GRP-96-644
Plastic Bowl / Bowl Guard, Manual Drain	GRP-96-642
Plastic Bowl, Plastic Guard, No Drain	GRP-96-652

Replacement Element Kit

Type "B", 0.5 Micron.....	MSP-96-649
---------------------------	------------

Accessories

Wall Mounting Bracket –	
L-Type	GPA-96-605
T-Type	GPA-96-602

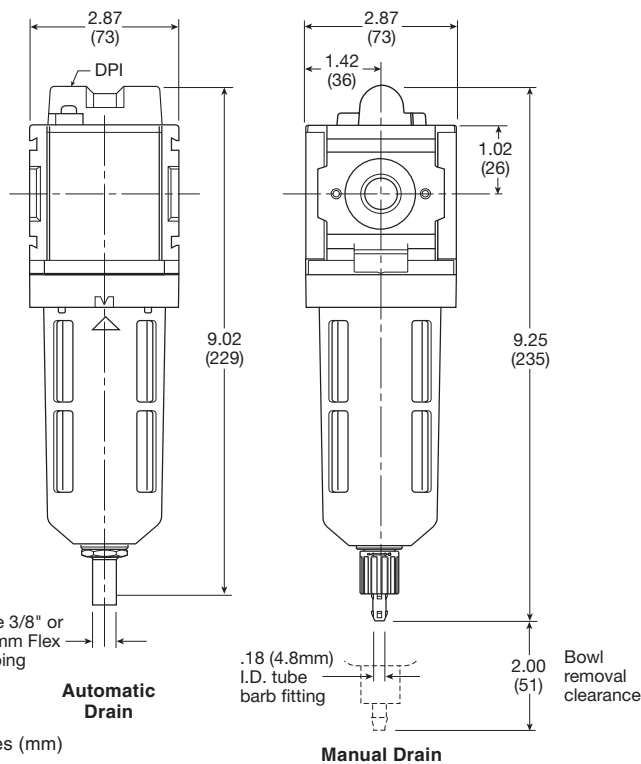

Inches (mm)

Ordering Information

Model Type	Port Size	Polycarbonate Bowl / Bowl Guard / "B" Element	Metal Bowl / Sight Gauge / "B" Element
Type "B" Element is Standard (Manual Drain)	3/8	A28-03-BK00B	A28-03-BL00B
	1/2	A28-04-BK00B	A28-04-BL00B
	3/4	A28-06-BK00B	A28-06-BL00B

Options - To order an option supplied with the unit model, add the appropriate coded suffix letter in the designated position of the model number.

Notes

Regulator Numbering System

 = "Most Popular"

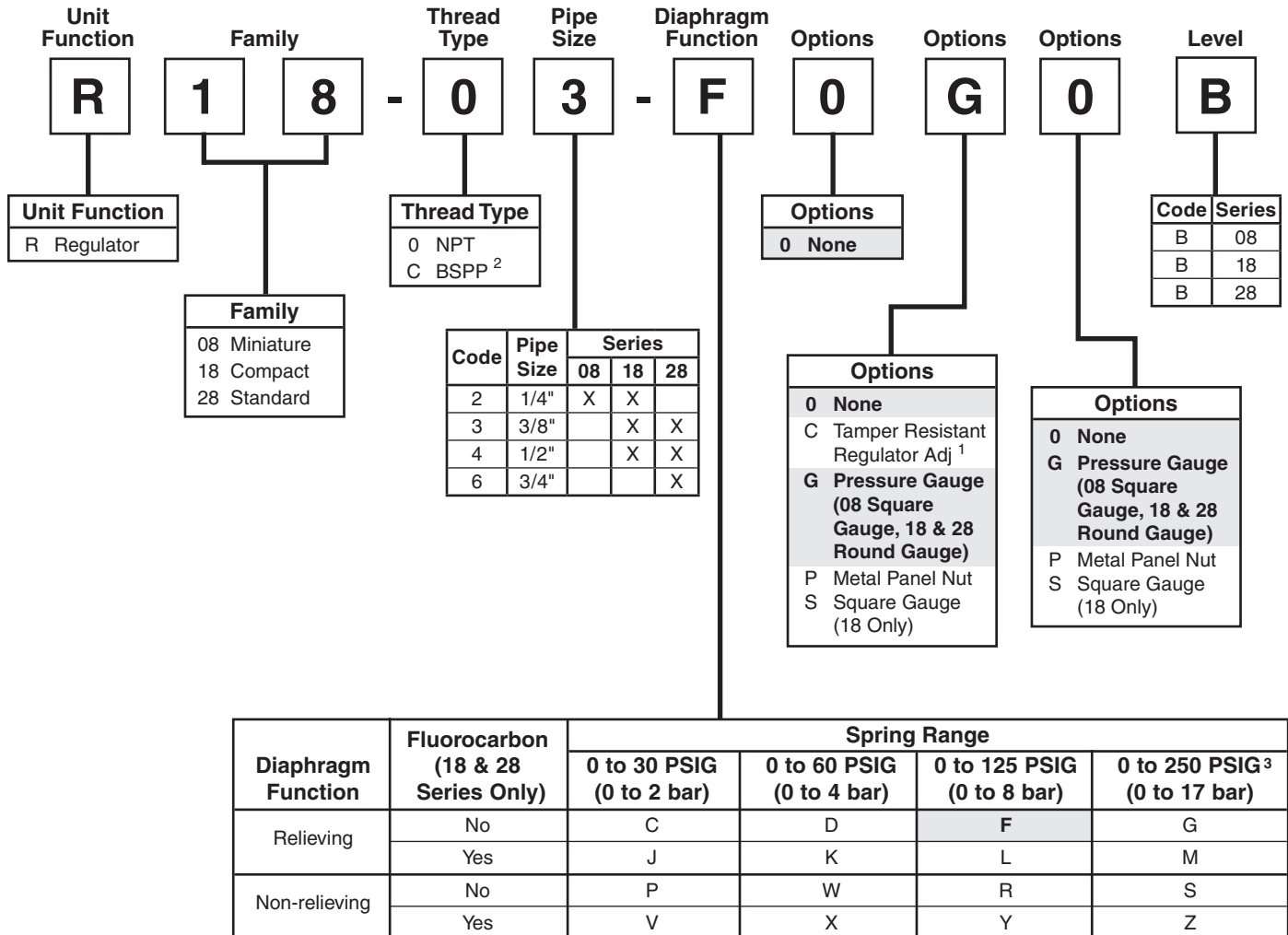

¹ Tamper kit not installed. Kit is shipped loose in carton, for 08, 18 & 28 NPT units.
² ISO, R228 (G Series).
³ R08 series operating range 0 to 232 PSIG (1 to 16 bar).

NOTE: When selecting from the options columns, please enter letters in alphabetical order for positions 7, 8, and 9. For example:

R 1 8 - 0 3 - F 0 G 0 B

Regulator R08

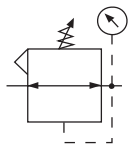

Relieving

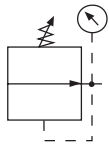

Non-Relieving



Features

- Balanced Valve Design
- 2 Gauge Ports
- Serviceability and Ease of Maintenance
- Unique Flush-mounted Pressure Gauge
- Light Weight
- Modern Design and Appearance

Specifications

Flow Capacity*	1/4	68 SCFM (32 dm ³ /s, ANR)
Adjusting Range Pressure		0 to 30 PSIG (0 to 2 bar)
		0 to 60 PSIG (0 to 4 bar)
		0 to 125 PSIG (0 to 8 bar)
		0 to 232 PSIG (0 to 16 bar)
Gauge Port (2 ea.)**	NPT / BSPP-G	1/8
Maximum Supply Pressure		300 PSIG (20.7 bar)
Operating Temperature†		-4° to 150°F (-20° to 65.5°C)
Port Size	NPT / BSPP-G	1/4
Weight		0.37 lb. (0.17 kg)

* Inlet pressure 145 psig (10 bar). Secondary pressure 91.3 psig (6.3 bar) and 14.5 psig (1 bar) pressure drop.

** Non-gauge option only.

† Units with square gauges: 5°F to 150°F (-15°C to 65.5°C)

Materials of Construction

Adjustment Knob	Acetal
Body	Aluminum
Body Cap	ABS
Bonnet	PBT
Diaphragm Assembly	Brass / Nitrile
Panel Nut	Acetal
Seals	Nitrile
Springs	Steel
Valve Assembly	Brass / Nitrile

⚠ WARNING

**Product rupture can cause serious injury.
Do not connect regulator to bottled gas.
Do not exceed maximum primary pressure rating.**

CAUTION:

REGULATOR PRESSURE ADJUSTMENT – The working range of knob adjustment is designed to permit outlet pressures within their full range. Pressure adjustment beyond this range is also possible because the knob is not a limiting device. This is a common characteristic of most industrial regulators, and limiting devices may be obtained only by special design.

For best performance, regulated pressure should always be set by increasing the pressure up to the desired setting.

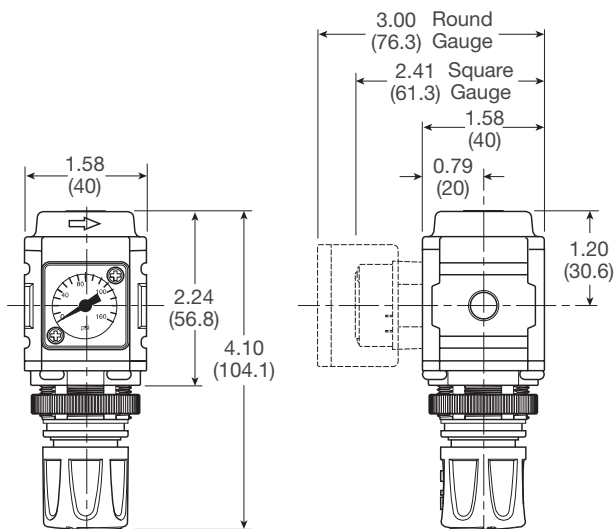

Inches (mm)

NOTE: 1.20 in. (30mm) hole required for panel nut mounting.

= "Most Popular"

Replacement Kits

- Diaphragm Assembly –
 - Non-relieving GRP-96-726B
 - Relieving GRP-96-725B
- Spring, Regulating –
 - 0 to 125 PSIG (0 to 8.6 bar) GRP-96-717B

Accessories

- Adjusting Knob RRP-16-005-000
- Panel Mount Nut –
 - Aluminum RPA-96-733
 - Plastic RPA-96-734
- Pressure Gauge –
 - Flush Mounted –
 - 0 to 150 PSIG K4511SCR160
 - 0 to 60 PSIG K4511SCR060
 - 0 to 4 bar K4511SCR04B
 - 0 to 11 bar K4511SCR11B
 - Square with adapter kit
 - 0-4 bar P6G-PR10040
 - 0-11 bar P6G-PR10110
 - 0-60 PSIG P6G-PR90060
 - 0-160 PSIG P6G-PR90160
 - 0 to 60 PSIG (0 to 4.1 bar),
 - 1-1/2" Dial Face, 1/8 NPT, CBM K4515N18060
 - 0 to 160 PSIG (0 to 11.0 bar),
 - 1-1/2" Dial Face, 1/8 NPT, CBM K4515N18160
- Tamper Resistant Kit RPA-96-735
- Tamperproof Lock and Cover Kit
(lock not included) RPA-96-736
- Wall Mounting Bracket –
 - C-Type GPA-97-010
 - L-Type GRP-96-739
 - T-Type GPA-96-737

R08 1/4" Regulator

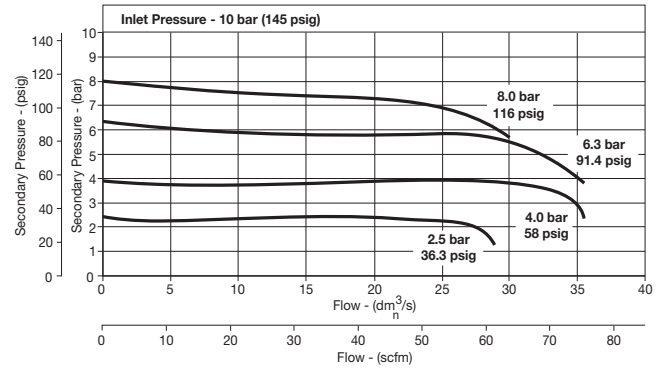

Ordering Information

Model Type	Port Size	With Gauge 0 to 125 PSIG (0 to 8.6 bar)	With Gauge 0 to 30 PSIG (0 to 2.1 bar)	With Gauge 0 to 60 PSIG (0 to 4.1 bar)	Without Gauge 0 to 125 PSIG (0 to 8.6 bar)
Relieving	1/4	R08-02-F0G0B	R08-02-C0G0B	R08-02-D0G0B	R08-02-F000B

Options - To order an option supplied with the unit model, add the appropriate coded suffix letter in the designated position of the model number.

Regulator R18

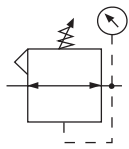

Relieving

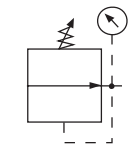

Non-Relieving



Features

- Balanced Valve Design
- Spring-loaded Diaphragm
- 4 Adjusting Pressure Ranges Available
- 1/2" NPT / BSPP-G Over-port
- 2 Gauge Ports
- Regulator will Reverse-flow as Standard

Specifications

Flow Capacity*	1/4	148 SCFM (70 dm ³ /s, ANR)
	3/8	165 SCFM (78 dm ³ /s, ANR)
	1/2	165 SCFM (78 dm ³ /s, ANR)
Adjusting Range Pressure		0 to 30 PSIG (0 to 2 bar)
		0 to 60 PSIG (0 to 4 bar)
		0 to 125 PSIG (0 to 8 bar)
		0 to 250 PSIG (0 to 17 bar)

Gauge Port (2 ea.)	NPT / BSPP-G	1/4
Maximum Supply Pressure		300 PSIG (20.7 bar)
Operating Temperature		-13° to 150°F (-25° to 65.5°C)
Port Size	NPT / BSPP-G	1/4, 3/8, 1/2
Weight		0.90 lb (0.41 kg)

* Inlet pressure 145 psig (10 bar). Secondary pressure 91.3 psig (6.3 bar) and 14.5 psig (1 bar) pressure drop.

Materials of Construction

Adjustment Knob		Acetal
Body		Aluminum
Body Cap		ABS
Bonnet		33% glass-filled nylon
Diaphragm Assembly		Nitrile / Steel
Valve Assembly		Brass / Nitrile
Panel Nut		Acetal
Seals		Nitrile
Springs	Main Regulating Valve	Steel Stainless Steel

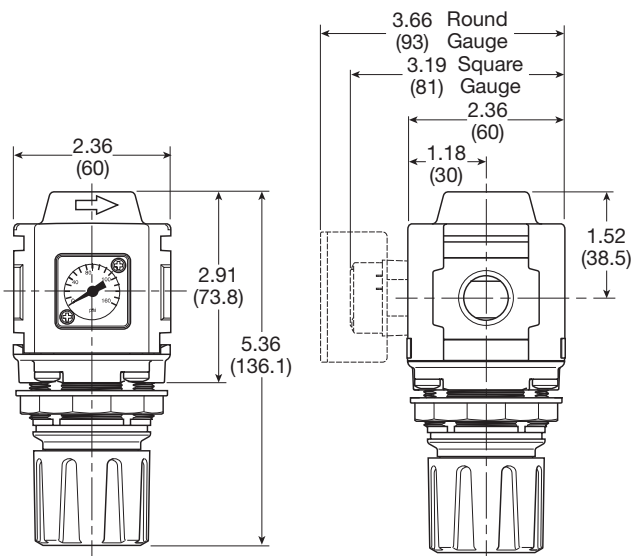

Inches (mm)

NOTE: 1.90 in. (48mm) hole required for panel nut mounting.

⚠ WARNING

**Product rupture can cause serious injury.
Do not connect regulator to bottled gas.
Do not exceed maximum primary pressure rating.**

CAUTION:

REGULATOR PRESSURE ADJUSTMENT – The working range of knob adjustment is designed to permit outlet pressures within their full range. Pressure adjustment beyond this range is also possible because the knob is not a limiting device. This is a common characteristic of most industrial regulators, and limiting devices may be obtained only by special design.

For best performance, regulated pressure should always be set by increasing the pressure up to the desired setting.

 = "Most Popular"

Replacement Kits

- Adjusting Knob..... RRP-96-655
- Diaphragm Assembly –
 - Non-relieving RRP-96-657B
 - Relieving..... RRP-96-656B
- Spring, Regulating –
 - 0 to 30 PSIG (0 to 2.1 bar) RRP-96-659B
 - 0 to 60 PSIG (0 to 4.1 bar) RRP-96-660B
 - 0 to 125 PSIG (0 to 8.6 bar) RRP-96-661B
 - 0 to 250 PSIG (0 to 17.2 bar) RRP-96-662B

Accessories

- Panel Mount Nut –
 - Aluminum..... RRP-96-673
 - Plastic..... RRP-96-675B
- Gauge, Pressure –
 - Square flush mount gauge
 - 0-4 bar K4511SCR04B
 - 0-11 bar K4511SCR11B
 - 0-60 PSIG..... K4511SCR060
 - 0-160 PSIG..... K4511SCR160
 - Square with adapter kit
 - 0-4 bar P6G-PR10040
 - 0-11 bar P6G-PR10110
 - 0-60 PSIG..... P6G-PR90060
 - 0-160 PSIG..... P6G-PR90160
 - 50mm (2") round 1/4" center back mount
 - 0-30 PSIG / 0-2 bar K4520N14030
 - 0-60 PSIG / 0-4 bar K4520N14060
 - 0-160 PSIG / 0-11 bar K4520N14160
 - 0-300 PSIG / 0-20 bar K4520N14300
 - 1-3/4" Digital Round 1/4" NPT
 - 0 to 160 PSIG..... K4517N14160D

For best performance, regulated pressure should always be set by increasing the pressure up to the desired setting.

- Tamper Resistant Kit..... RRP-96-671
- Tamperproof Lock and Cover Kit..... RPA-96-737
- Tamperproof Knob Kit..... RPA-96-738
- Wall Mounting Bracket –
 - L-Type GPA-96-606
 - T-Type GPA-96-602

R18 1/4" Regulator

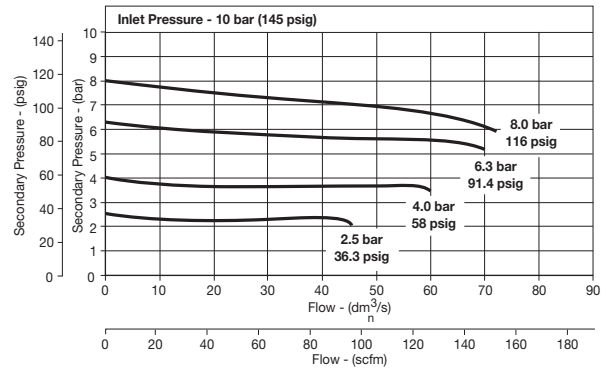

R18 3/8" Regulator

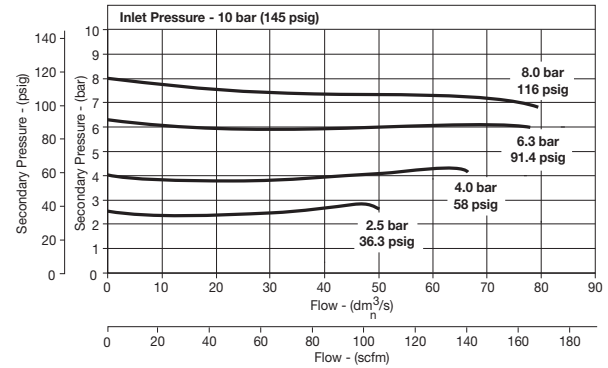

R18 1/2" Regulator

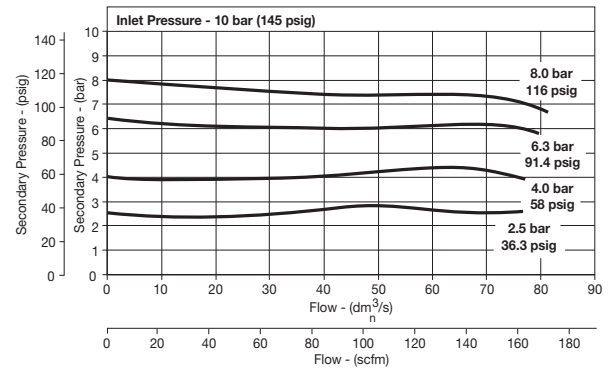

Ordering Information

Model Type	Port Size	With Gauge 5 to 125 PSIG (0.4 to 8.6 bar)	With Gauge 10 to 250 PSIG (0.7 to 17.2 bar)	With Gauge 3 to 60 PSIG (0.2 to 4.1 bar)	Without Gauge 5 to 125 PSIG (0.4 to 8.6 bar)
Relieving	1/4	R18-02-F0G0B	R18-02-G0G0B	R18-02-D0G0B	R18-02-F000B
	3/8	R18-03-F0G0B	R18-03-G0G0B	R18-03-D0G0B	R18-03-F000B
	1/2	R18-04-F0G0B	R18-04-G0G0B	R18-04-D0G0B	R18-04-F000B

Options - To order an option supplied with the unit model, add the appropriate coded suffix letter in the designated position of the model number.

Regulator R28

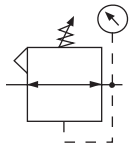

Relieving

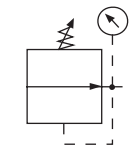

Non-Relieving



Features

- Balanced Valve Design
- Spring-loaded Diaphragm
- 4 Adjusting Pressure Ranges Available
- 3/4" NPT / BSPP-G Over-port
- Reverse-flow Available
- 2 Gauge Ports

Specifications

Flow Capacity*	3/8	228 SCFM (108 dm ³ /s, ANR)
	1/2	233 SCFM (110 dm ³ /s, ANR)
	3/4	233 SCFM (110 dm ³ /s, ANR)
Adjusting Range Pressure		0 to 30 PSIG (0 to 2 bar)
		0 to 60 PSIG (0 to 4 bar)
		0 to 125 PSIG (0 to 8 bar)
		0 to 250 PSIG (0 to 17 bar)

Gauge Port (2 ea.)	NPT / BSPP-G	1/4
Maximum Supply Pressure		300 PSIG (20.7 bar)
Operating Temperature		-13° to 150°F (-25° to 65.5°C)
Port Size	NPT / BSPP-G	3/8, 1/2, 3/4
Weight		1.37 lb. (0.62 kg)

* Inlet pressure 145 psig (10 bar). Secondary pressure 91.3 psig (6.3 bar) and 14.5 psig (1 bar) pressure drop.

Materials of Construction

Adjustment Knob	Acetal
Body	Aluminum
Body Cap	ABS
Bonnet	33% Glass-filled Nylon
Diaphragm Assembly	Nitrile / Zinc
Panel Nut	Acetal
Seals	Nitrile
Springs	Main Regulating Valve: Steel, Stainless Steel
Valve Assembly	Brass / Nitrile / Acetal

! WARNING

**Product rupture can cause serious injury.
Do not connect regulator to bottled gas.
Do not exceed maximum primary pressure rating.**

CAUTION:

REGULATOR PRESSURE ADJUSTMENT – The working range of knob adjustment is designed to permit outlet pressures within their full range. Pressure adjustment beyond this range is also possible because the knob is not a limiting device. This is a common characteristic of most industrial regulators, and limiting devices may be obtained only by special design.

For best performance, regulated pressure should always be set by increasing the pressure up to the desired setting.

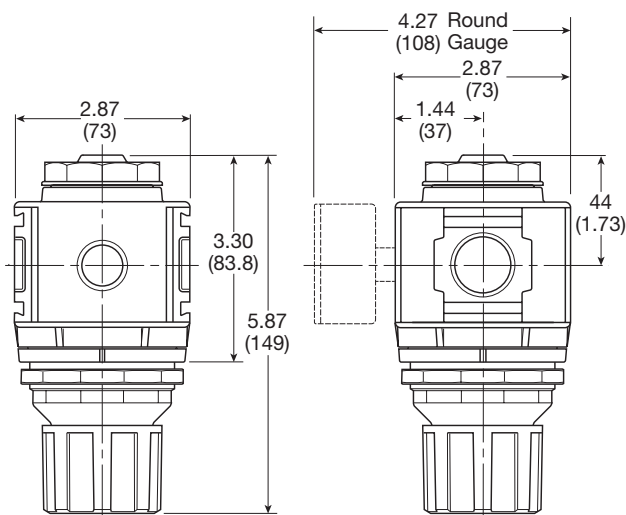

Inches (mm)

NOTE: 2.40 in. (61mm) hole required for panel nut mounting.

= "Most Popular"

Replacement Kits

- Diaphragm Assembly –
 - Non-relieving RRP-96-987
 - Relieving RRP-96-986
- Valve Assembly RRP-96-049
- Adjusting Knob RRP-16-341-000
- Spring, Regulating
 - 0 to 30 PSIG (0 to 2.1 bar) RRP-96-163
 - 0 to 60 PSIG (0 to 4.1 bar) RRP-96-164
 - 0 to 125 PSIG (0 to 8.6 bar) RRP-96-165
 - 0 to 250 PSIG (0 to 17.2 bar) RRP-96-166

Accessories

- Panel Mount Nut –
 - Aluminum RRP-96-674
 - Plastic RRP-96-676
- Gauge, Pressure –
 - 50mm (2") round 1/4" center back mount
 - 0-30 PSIG / 0-2 bar K4520N14030
 - 0-60 PSIG / 0-4 bar K4520N14060
 - 0-160 PSIG / 0-11 bar K4520N14160
 - 0-300 PSIG / 0-20 bar K4520N14300
 - 0 to 160 PSIG, 1-3/4" Digital Round, 1/4" NPT K4517N14160D
- Tamper Resistant Kit RRP-96-672
- Wall Mounting Bracket
 - L-Type GPA-96-607
 - T-Type GPA-96-602

R28 3/8" Regulator

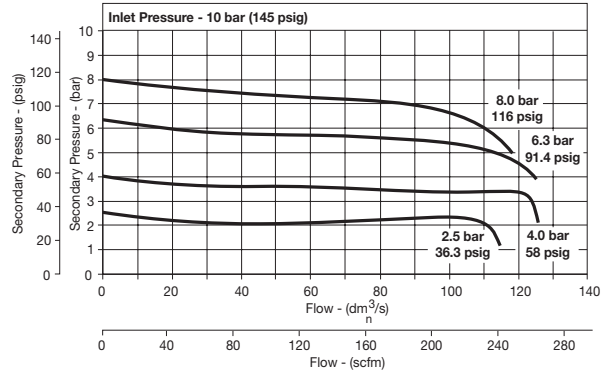

R28 1/2" Regulator

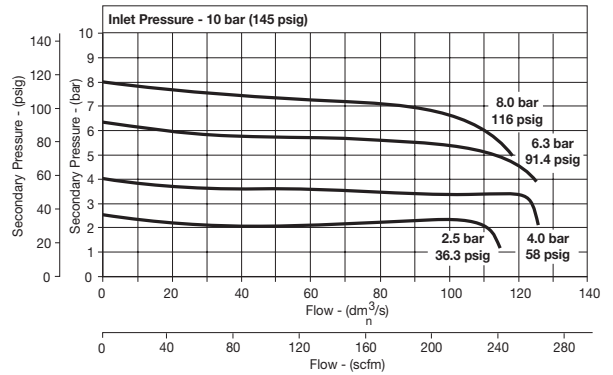

R28 3/4" Regulator

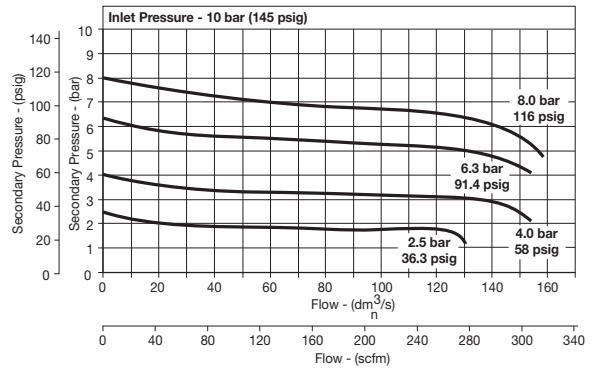

Ordering Information

Model Type	Port Size	With Gauge 5 to 125 PSIG (0.4 to 8.6 bar)	With Gauge 10 to 250 PSIG (0.7 to 17.2 bar)	With Gauge 3 to 60 PSIG (0.2 to 4.1 bar)	Without Gauge 5 to 125 PSIG (0.4 to 8.6 bar)
Relieving	3/8	R28-03-F0G0B	R28-03-G0G0B	R28-03-D0G0B	R28-03-F000B
	1/2	R28-04-F0G0B	R28-04-G0G0B	R28-04-D0G0B	R28-04-F000B
	3/4	R28-06-F0G0B	R28-06-G0G0B	R28-06-D0G0B	R28-06-F000B

Options - To order an option supplied with the unit model, add the appropriate coded suffix letter in the designated position of the model number.

Regulator R90



Symbols

= "Most Popular"

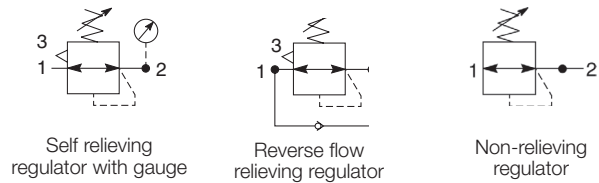

Features

- Integral 3/4" or 1" ports (BSPP & NPT)
- Robust but lightweight aluminum construction
- Secondary pressure ranges 12 and 16 bar
- Rolling diaphragm for extended life
- Secondary aspiration plus rolling diaphragm provides quick response and accurate pressure regulation
- Optional tamperproof regulator padlock
- Reverse flow / relieving option
- Low temperature -40°

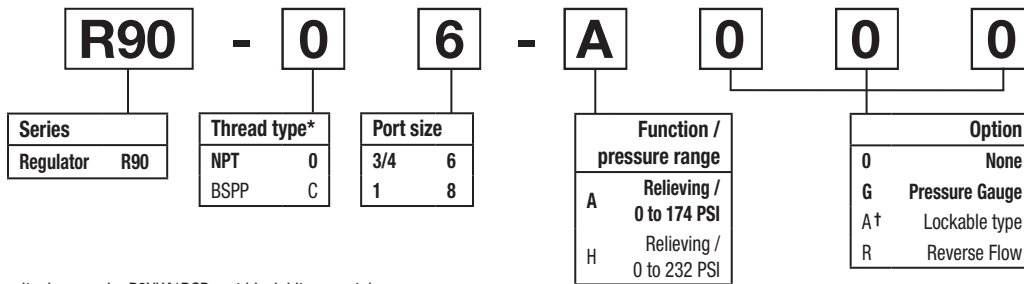

Notes:
 * For 1-1/2" ported unit, please order P3YKA*BCP port block kit separately.
 † Not field convertible.
Bold items are most common.

Ordering information

Port size	Description	Flow ‡ scfm	Max. bar (psig)	Min temp °C (°F)	Max temp °C (°F)	Height mm (inches)	Width mm (inches)	Depth mm (inches)	Weight kg (lb)	Part number †
3/4"	12 bar relieving	380	17.5 (254)	-40 (-40)	60 (140)	182 (7.2)	90 (3.5)	94 (3.7)	1.08 (2.4)	R90-06-A000
3/4"	12 bar relieving + pressure gauge	380	17.5 (254)	-10 (14)	60 (140)	182 (7.2)	90 (3.5)	94 (3.7)	1.13 (2.5)	R90-06-AG00
1"	12 bar relieving	550	17.5 (254)	-40 (-40)	60 (140)	182 (7.2)	90 (3.5)	94 (3.7)	1.08 (2.4)	R90-08-A000
1"	12 bar relieving + pressure gauge	550	17.5 (254)	-10 (14)	60 (140)	182 (7.2)	90 (3.5)	94 (3.7)	1.19 (2.6)	R90-08-AG00

† **Standard part numbers shown in bold. For other models refer to Options chart above.**
 ‡ Flow with 6.3 bar (91.4 psig) inlet pressure and 0.5 (7.3 psig) pressure drop.

Specifications

Fluid	Compressed air
Maximum inlet pressure*	17.5 bar (254 psig)
Temperature range*	-40°C to 60°C (-40°F to 140°F)
Typical flow with 10 bar (145 psig) inlet pressure and 6.3 bar (91 psig) set pressure and 0.5 bar (7.3 psig) pressure drop	1" size 550 scfm
Gauge port (x 2)	1/4"

* Air supply must be dry enough to avoid ice formation at temperatures below 2°C (35.6°F).

Dimensions mm (inches)

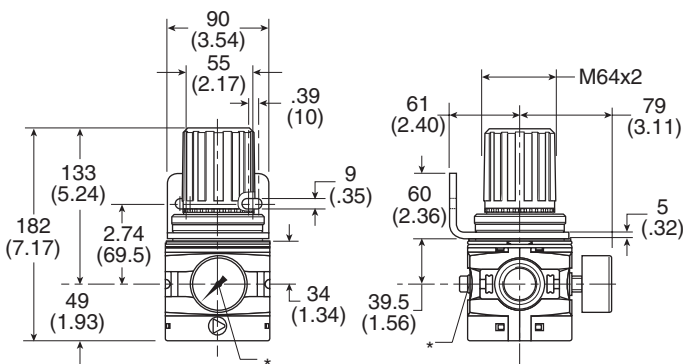

* 1/4" gauge port

Service kits

Angle bracket + metal lock ring	P3YKA00MS
Panel mounting nut	P3YKA00MM
Diaphragm kit (relieving type).....	P3YKA00RR
Diaphragm kit (non-relieving type)	P3YKA00RN
Gauge - 1/4" port	
0 to 10 bar (0 to 160 psig).....	K4520N14160
0 to 20 bar (0 to 300 psig)	K4520N14300

⚠ WARNING

**Product rupture can cause serious injury.
Do not connect regulator to bottled gas.
Do not exceed maximum primary pressure rating.**

Material specifications

Body	Aluminum
Bonnet	Glass filled polyamide
Regulator cover	ABS
Control knob	Glass filled polyamide
Valve	Brass / NBR
Seals	Nitrile NBR
Screws	Steel / zinc plated

Flow characteristics

(3/4") Regulator

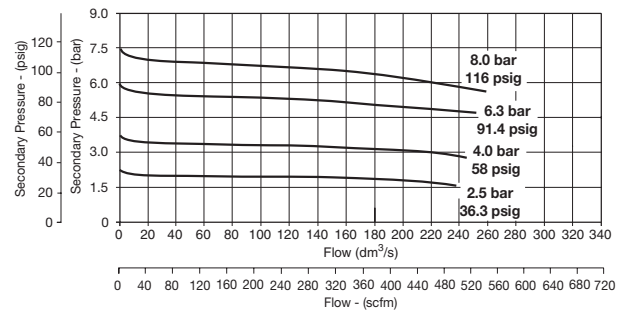

(1") Regulator

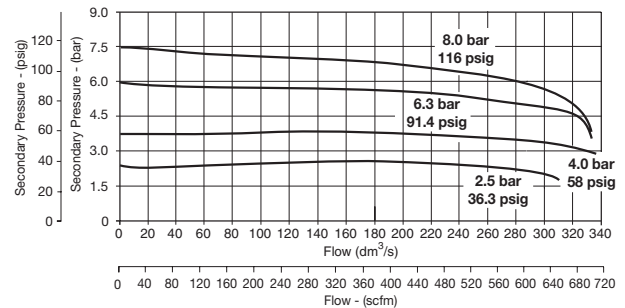

CAUTION:

REGULATOR PRESSURE ADJUSTMENT – The working range of knob adjustment is designed to permit outlet pressures within their full range. Pressure adjustment beyond this range is also possible because the knob is not a limiting device. This is a common characteristic of most industrial regulators, and limiting devices may be obtained only by special design.

For best performance, regulated pressure should always be set by increasing the pressure up to the desired setting.

Pilot Operated Regulator R90



Symbol

= "Most Popular"

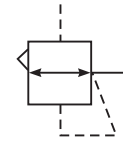

Features

- Integral 3/4" or 1" ports (BSPP & NPT)
- Pilot controlled regulators can be mounted "out of reach" with pilot regulator installed in a convenient location
- Constant pilot bleed control for accurate pressure control
- Balanced poppet provides quick response
- High flow

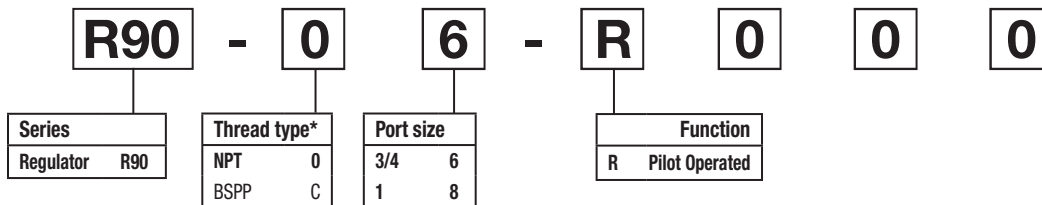

*Note: For 1-1/2" ported unit, please order P3YKA*BCP port block kit separately.
Bold items are most common.

Ordering information

Port size	Description	Flow [‡] scfm	Max. bar (psig)	Min temp °C (°F)	Max temp °C (°F)	Height mm (inches)	Width mm (inches)	Depth mm (inches)	Weight kg (lb)	Part number [†]
3/4"	Pilot operated regulator	550	17.5 (254)	-10 (14)	60 (140)	105.5 (4.15)	90 (3.54)	90 (3.54)	1.2 (2.6)	R90-06-R000
1"	Pilot operated regulator	550	17.5 (254)	-10 (14)	60 (140)	105.5 (4.15)	90 (3.54)	90 (3.54)	1.2 (2.6)	R90-08-R000

[†] Standard part numbers shown in bold. For other models refer to Options chart above.

[‡] Flow with 10 bar (145 psig) inlet pressure, 6.3 bar (91.4 psig) set pressure and 1 bar (14.5 psig) pressure drop.

Specifications

Fluid	Compressed air
Max. pressure air pilot operated	17.5 bar (254 psig)
Operating temperature	-10°C to 60°C (14°F to 140°F)
Weight	3/4" 1.2 kg (2.6 lb)
	1" 1.2 kg (2.6 lb)

Material specifications

Body	Aluminum
Body cover	ABS
Valve	Brass / NBR composite
Pilot valve booster	Aluminum
Seals	Nitrile NBR
Screws	Zinc plated steel

Dimensions mm (inches)

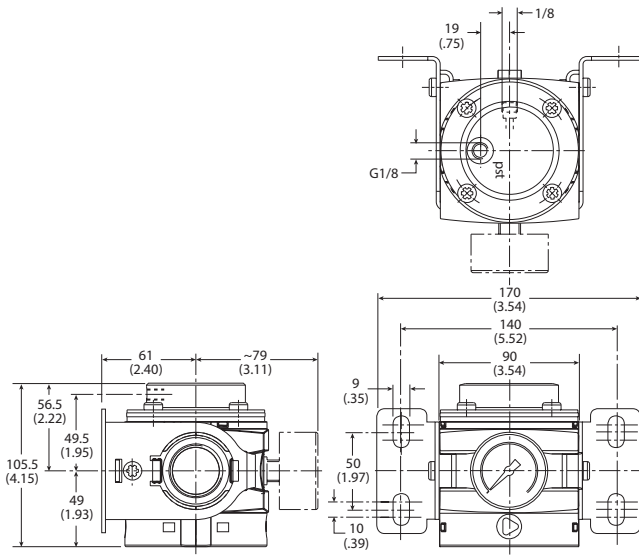

Flow characteristics

3/4" and 1" Pilot Regulator

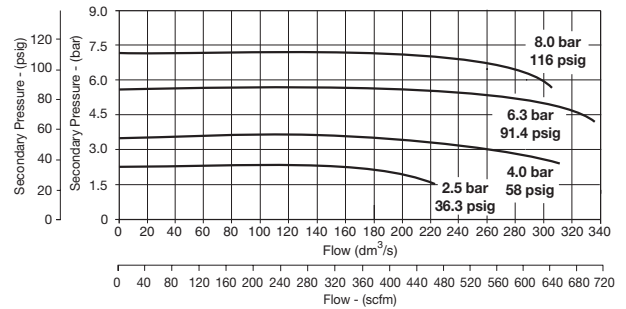

! WARNING

**Product rupture can cause serious injury.
Do not connect regulator to bottled gas.
Do not exceed maximum primary pressure rating.**

CAUTION:

REGULATOR PRESSURE ADJUSTMENT – The working range of knob adjustment is designed to permit outlet pressures within their full range. Pressure adjustment beyond this range is also possible because the knob is not a limiting device. This is a common characteristic of most industrial regulators, and limiting devices may be obtained only by special design.

For best performance, regulated pressure should always be set by increasing the pressure up to the desired setting.

Notes

Common-P1 Regulator Numbering System

 = "Most Popular"

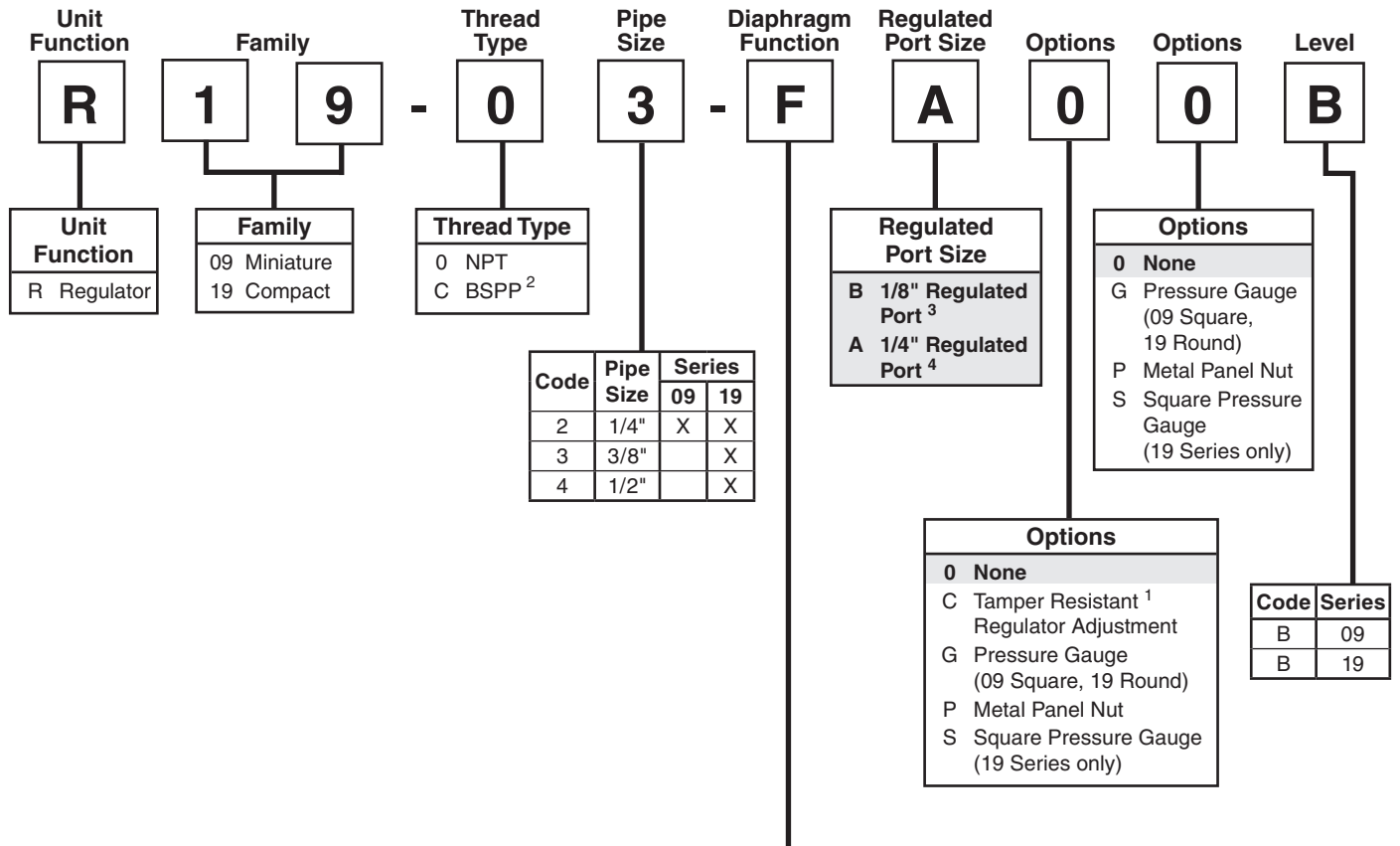

Diaphragm Function	Fluorocarbon (19 Series Only)	Spring Range			
		0 to 30 PSIG (0 to 2.1 bar)	0 to 60 PSIG (0 to 4.1 bar)	0 to 125 PSIG (0 to 8.6 bar)	0 to 250 PSIG ⁵ (0 to 17.2 bar)
Relieving	No	C	D	F	G
	Yes	J	K	L	M
Non-relieving	No	P	W	R	S
	Yes	V	X	Y	Z

1 Tamper kit not installed. Kit is shipped loose in carton.
 2 ISO, R228 (G Series).
 3 Not available on R19.
 4 Not available on R09.
 5 R09 series operating range 0 to 232 PSIG (1 to 16 bar).

Note: When selecting from the options columns, please enter letters in alphabetical order, for example:

R 1 9 - 0 3 - F A 0 0 B

Common-P1 Regulator R09

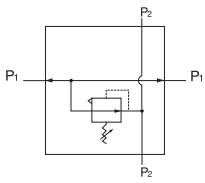

Relieving

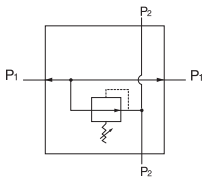

Non-Relieving



Specifications

Flow Capacity*	1/4	42 SCFM (20 dm ³ /s)
Adjusting Range Pressure		0 to 30 PSIG (0 to 2.1 bar)
		0 to 60 PSIG (0 to 4.1 bar)
		0 to 125 PSIG (0 to 8.6 bar)
Maximum Supply Pressure		300 PSIG (20.7 bar)
Operating Temperature		-4° to 150°F (-20° to 65.5°C)
P1 Port Size (Inlet / Outlet)	NPT / BSPP-G	1/4
P2 Regulated Ports (2 ea.)	NPT / BSPP-G	1/8
Weight		0.37 lb (0.17 kg)

* Inlet pressure 100 PSIG (6.9 bar). Secondary pressure 90 PSIG (6.2 bar).

Features

- Balanced Valve Design
- 2 Regulated Ports
- Ease of Maintenance of Serviceability
- Light Weight
- Modern Design and Appearance

Materials of Construction

Adjustment Knob	Acetal
Body	Aluminum
Body Cap	ABS
Bonnet	33% Glass-filled PBT
Bottom Plug	33% Glass-filled Nylon
Diaphragm Assembly	Brass / Nitrile
Valve Assembly	Brass / Nitrile

WARNING

**Product rupture can cause serious injury.
Do not connect regulator to bottled gas.
Do not exceed maximum primary pressure rating.**

CAUTION:

REGULATOR PRESSURE ADJUSTMENT – The working range of knob adjustment is designed to permit outlet pressures within their full range. Pressure adjustment beyond this range is also possible because the knob is not a limiting device. This is a common characteristic of most industrial regulators, and limiting devices may be obtained only by special design.

For best performance, regulated pressure should always be set by increasing the pressure up to the desired setting.

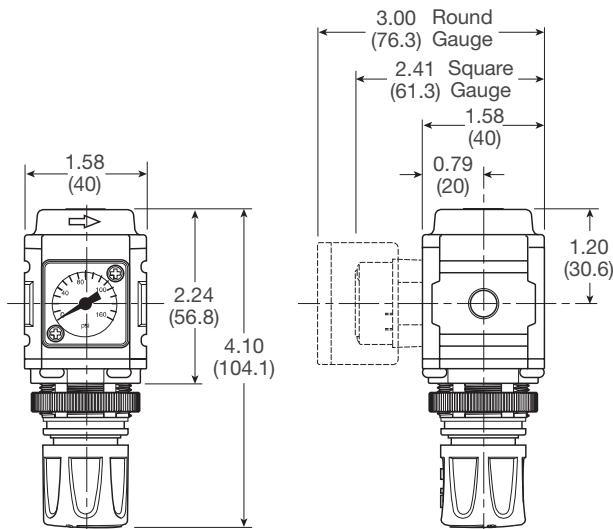

Inches (mm)

NOTE: 1.90 in. (48mm) hole required for panel nut mounting.

 = "Most Popular"

Replacement Kits

- Diaphragm Assembly –
 - Non-relieving..... GRP-96-726B
 - Relieving..... GRP-96-725B
- Spring, Regulating –
 - 0 to 30 PSIG (0 to 2.1 bar) GRP-95-111B
 - 0 to 60 PSIG (0 to 4.1 bar) GRP-96-718B
 - 0 to 125 PSIG (0 to 8.6 bar) GRP-96-717B

Accessories

- Gauge, Pressure –
 - 0 to 60 PSIG (0 to 4.1 bar),
1.00" Dial Face, 1/8" NPT, CBM K4510N18060
 - 0 to 160 PSIG (0 to 11.0 bar),
1.00" Dial Face, 1/8" NPT, CBM K4510N18160
- Panel Mount Nut –
 - Aluminum..... RPA-96-733
 - Plastic..... RPA-96-734
- Tamper Resistant Kit..... RPA-96-735
- Wall Mounting Bracket –
 - C-Type GPA-97-010
 - L-Type..... GRP-96-739
 - T-Type GPA-96-737

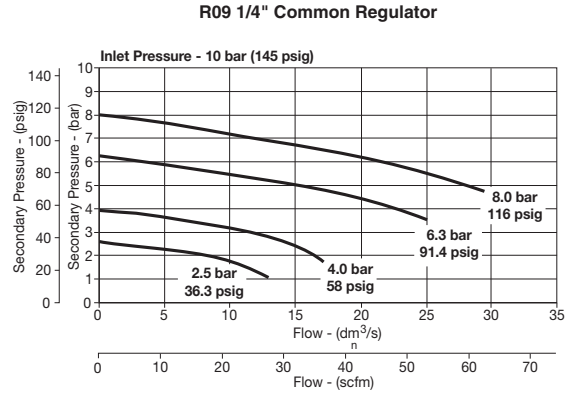

NOTE: Square gauge not included, order separately by accessory number.

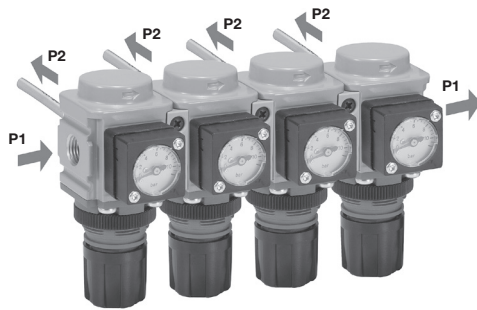

Typical Application

Ordering Information

All P2 Regulated Ports are 1/8" Ports

Model Type	P1 Port Size	Without Gauge 0 to 125 PSIG (0 to 8.6 bar)	Without Gauge 0 to 30 PSIG (0 to 2.1 bar)	Without Gauge 0 to 60 PSIG (0 to 4.1 bar)
Relieving	1/4	R09-02-FB00B	R09-02-CB00B	R09-02-DB00B
Non-relieving	1/4	R09-02-RB00B	R09-02-PB00B	R09-02-WB00B

Options - To order an option supplied with the unit model, add the appropriate coded suffix letter in the designated position of the model number.

Common-P1 Regulator R19

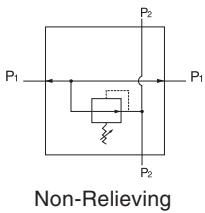
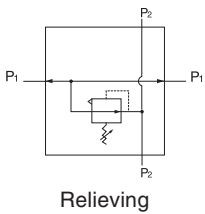

Specifications

Flow Capacity*	1/4, 3/8, 1/2	64.0 SCFM (30 dm ³ /s)
Adjusting Range Pressure		0 to 30 PSIG (0 to 2.1 bar)
		0 to 60 PSIG (0 to 4.1 bar)
		0 to 125 PSIG (0 to 8.6 bar)
		0 to 250 PSIG (0 to 17.2 bar)
Maximum Supply Pressure		300 PSIG (20.7 bar)
Operating Temperature		-13° to 150°F (-25° to 65.5°C)
P1 Port Size (Inlet / Outlet)	NPT / BSPP-G	1/4, 3/8, 1/2
P2 Regulated Ports (2 ea.)	NPT / BSPP-G	1/4
Weight		0.50 lb (0.22 kg)

* Inlet pressure 100 PSIG (6.9 bar). Secondary pressure 90 PSIG (6.2 bar).

Features

- Balanced Valve Design
- Spring-loaded Diaphragm
- 4 Adjusting Pressure Ranges Available
- 1/2" NPT / BSPP-G Over-port
- 2 Regulated Ports

Materials of Construction

Adjustment Knob	Acetal	
Body	Aluminum	
Body Cap	ABS	
Bonnet	33% Glass-filled Nylon	
Bottom Plug	33% Glass-filled Nylon	
Diaphragm Assembly	Nitrile / Steel	
Panel Nut	Acetal	
Seals	Nitrile	
Springs	Main Regulating Valve	Steel
		Stainless Steel
Valve Assembly	Brass / Nitrile	

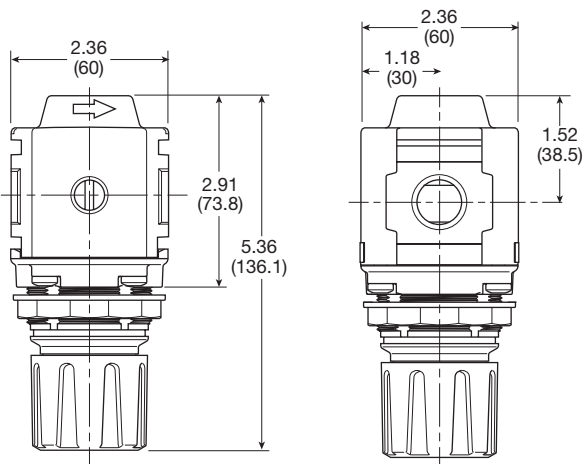

Inches (mm)

NOTE: 1.90 in. (48mm) hole required for panel nut mounting.

Inches (mm)

! WARNING

Product rupture can cause serious injury.
Do not connect regulator to bottled gas.
Do not exceed maximum primary pressure rating.

CAUTION:

REGULATOR PRESSURE ADJUSTMENT – The working range of knob adjustment is designed to permit outlet pressures within their full range. Pressure adjustment beyond this range is also possible because the knob is not a limiting device. This is a common characteristic of most industrial regulators, and limiting devices may be obtained only by special design.

For best performance, regulated pressure should always be set by increasing the pressure up to the desired setting.

 = "Most Popular"

Replacement Kits

- Diaphragm Assembly –
 - Non-relieving RRP-96-761B
 - Relieving..... RRP-96-760B
- Spring, Regulating–
 - 0 to 30 PSIG (0 to 2.1 bar) RRP-96-659B
 - 0 to 60 PSIG (0 to 4.1 bar) RRP-96-660B
 - 0 to 125 PSIG (0 to 8.6 bar) RRP-96-661B
 - 0 to 250 PSIG (0 to 17.2 bar) RRP-96-662B

Accessories

- Gauge, Pressure –
 - 50mm (2") round 1/4" center back mount
 - 0-30 PSIG / 0-2 bar K4520N14030
 - 0-60 PSIG / 0-4 bar K4520N14060
 - 0-160 PSIG / 0-11 bar K4520N14160
 - 0-300 PSIG / 0-20 bar K4520N14300
 - 0 to 160 PSIG, 1-3/4" Digital Round, 1/4" NPT K4517N14160D
- Panel Mount Nut –
 - Aluminum..... RRP-96-673
 - Plastic RRP-96-675
- Tamper Resistant Kit..... RRP-96-671
- Wall Mounting Bracket –
 - L-Type GPA-96-606
 - T-Type GPA-96-603

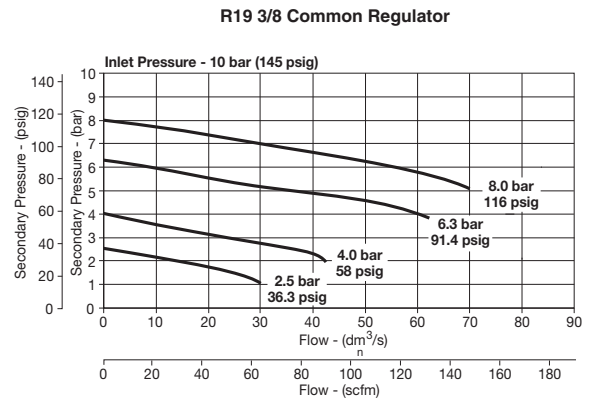

NOTE: Gauge not included, order separately by accessory number.



Typical Application

Ordering Information

All units shown with 1/4" regulated ports.

Model Type	P1 Port Size	5-125 PSIG (0.4 to 8.6 bar)	10-250 PSIG (0.7 to 7.2 bar)	3-60 PSIG (0.2 to 4.1 bar)
Relieving	1/4	R19-02-FA00B	R19-02-G700B	R19-02-DA00B
	3/8	R19-03-FA00B	R19-03-G700B	R19-03-DA00B
	1/2	R19-04-FA00B	R19-04-G700B	R19-04-DA00B
Non-relieving	1/4	R19-02-RA00B	R19-02-S700B	R19-02-WA00B
	3/8	R19-03-RA00B	R19-03-S700B	R19-03-WA00B
	1/2	R19-04-RA00B	R19-04-S700B	R19-04-WA00B

Options - To order an option supplied with the unit model, add the appropriate coded suffix letter in the designated position of the model number.

Notes

Lubricator Numbering System

 = "Most Popular"

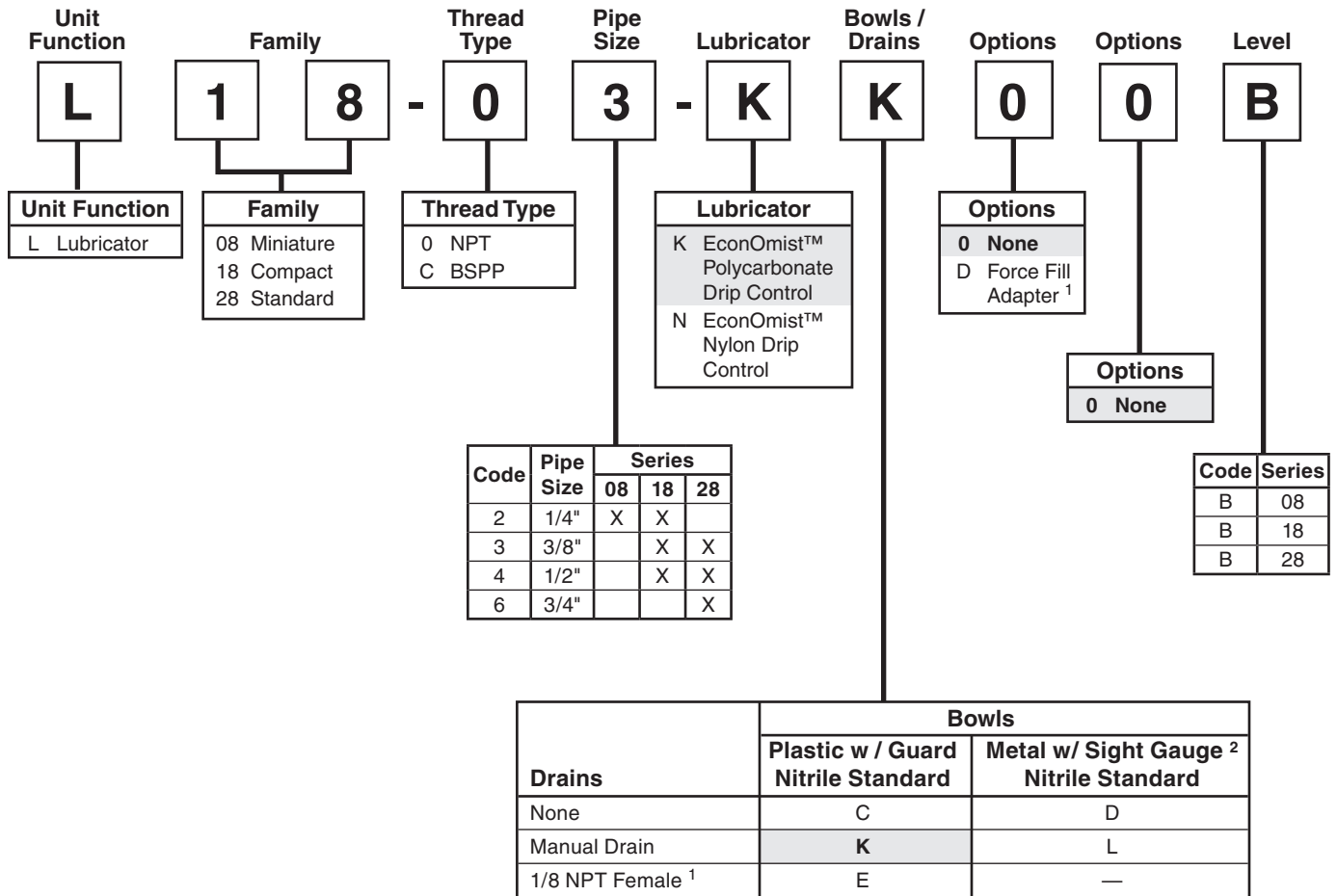

¹ Not available on L08

² No sight gauge on L08

Note: When selecting from the options columns, please enter letters in alphabetical order for positions 7, 8, and 9.
 For example:

L 1 8 - 0 3 - K K 0 0 B

Lubricator L08 EconOmist™

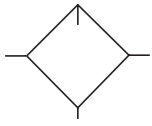

Features

- Integral Sight Dome and Adjustment Knob
- Fill-under Pressure Design
- Modern Design and Appearance
- Light Weight
- High Flow Capacity
- Quick-disconnect Bowl

Specifications

Flow Capacity*	1/4	52 SCFM (25 dm ³ /s, ANR)
Initial Drip Flow		1.3 SCFM
Maximum Supply Pressure	Plastic Bowl Metal Bowl	150 PSIG (10.3 bar) 250 PSIG (17.2 bar)
Minimum Flow for Lubrication		1.3 SCFM @ 100 PSIG
Operating Temperature	Plastic Bowl Metal Bowl	14° to 125°F (-10° to 52°C) 14° to 150°F (-10° to 65.5°C)
Port Size		NPT / BSPP-G 1/4
Bowl Capacity		0.6 oz
Weight		0.29 lb. (0.13 kg)

* Inlet pressure 91.3 PSIG (6.3 bar). Pressure drop 4.9 PSID (0.34 bar).

Materials of Construction

Body	Aluminum	
Body Cap	ABS	
Bowls	Plastic Bowl Metal Bowl	Polycarbonate Aluminum
Pick-up Filter	Sintered Bronze	
Seals	Plastic Bowl Metal Bowl	Nitrile Nitrile
Sight Dome	Polycarbonate	
Suggested Lubricant	Airline Oil F442001	

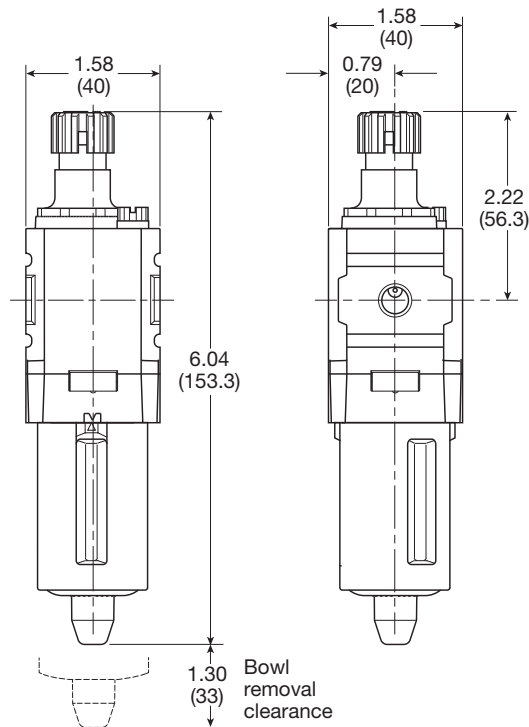

Inches (mm)

= "Most Popular"

Replacement Bowl Kits

- Metal Bowl –
- Manual Drain GRP-96-714
- No Drain Port..... GRP-96-715

- Plastic Bowl –
- Bowl Guard, Manual Drain LRP-96-736
- Bowl Guard, No Drain Port LRP-96-713

Replacement Kits

- Bowl O-ring –
- Fluorocarbon GRP-96-711
- Nitrile..... GRP-96-710

- Fill Plug Kit LRP-96-730

- Sight Dome Assembly –
- Nylon..... LRP-96-720
- Polycarbonate, L08-XX-KXXX LRP-96-725

- Siphon Tube Assembly LRP-96-731

Accessories

- Wall Mounting Bracket –
- C-Type GPA-97-010
- T-Type GPA-96-737

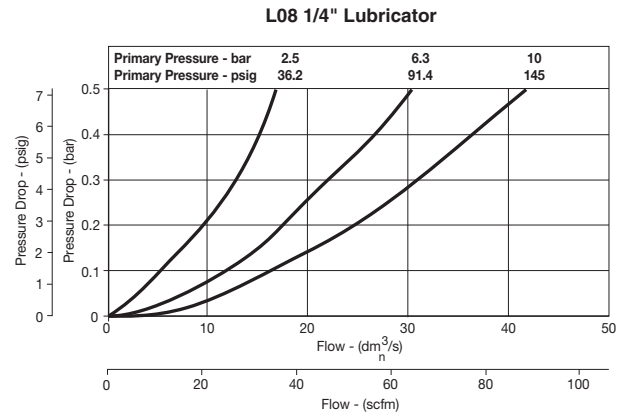

Ordering Information

Model Type	Port Size	Plastic Bowl / Bowl Guard	Metal Bowl / No Sight Gauge
No Drain	1/4	L08-02-KC00B	L08-02-KD00B
Manual Drain	1/4	L08-02-KK00B	L08-02-KL00B

Options - To order an option supplied with the unit model, add the appropriate coded suffix letter in the designated position of the model number.

Lubricator L18 EconOmist™

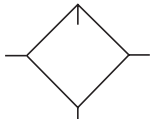

Features

- Integral Sight Dome and Adjustment Knob
- 1/2" NPT / BSPP-G Over-port
- Can be Filled while Under Pressure
- Quick-disconnect Bowl / Bowl Guard
- Manual Drain
- High Flow Capacities

Specifications

Flow Capacity*	1/4	88 SCFM (42 dm ³ /s, ANR)
	3/8	90 SCFM (43 dm ³ /s, ANR)
	1/2	96 SCFM (45 dm ³ /s, ANR)
Initial Drip Flow	0.68 SCFM	
Maximum Supply Pressure	Plastic Bowl	150 PSIG (10.3 bar)
	Metal Bowl	250 PSIG (17.2 bar)
Minimum Flow for Lubrication	.7 SCFM @ 100 PSIG	
Operating Temperature	Plastic Bowl	14° to 125°F (-10° to 52°C)
	Metal Bowl	14° to 150°F (-10° to 65.5°C)
Port Size	NPT / BSPP-G	1/4, 3/8, 1/2
Bowl Capacity	4 oz	
Weight	0.68 lb. (0.31 kg)	

* Inlet pressure 91.3 PSIG (6.3 bar). Pressure drop 4.9 PSID (0.34 bar).

Materials of Construction

Body	Aluminum	
Body Cap	ABS	
Bowls	Plastic Bowl	Polycarbonate
	Metal Bowl	Aluminum
Pick-up Filter	Sintered Bronze	
Seals	Plastic Bowl	Nitrile
	Metal Bowl	Nitrile
Sight Dome	Polycarbonate	
Sight Gauge	Metal Bowl	Polyamide (Nylon)
Suggested Lubricant	Airline Oil F442001	

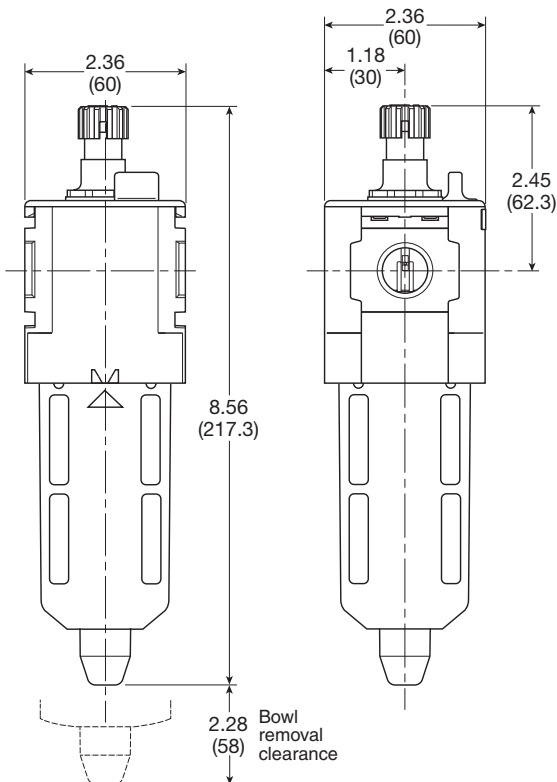

Inches (mm)

= "Most Popular"

Replacement Bowl Kits

- Metal Bowl with Sight Gauge, Manual Drain..... GRP-96-636
- Plastic Bowl / Bowl Guard, Manual Drain..... LRP-96-701

Replacement Kits

- Bowl O-ring –
 - Fluorocarbon GRP-96-754
 - Nitrile..... GRP-96-640
- Bypass Assembly..... LRP-96-678
- Fill Plug Kit LRP-96-679
- Sight Dome Assembly –
 - Nylon..... LRP-96-720
 - Polycarbonate, L18-XX-KK00..... LRP-96-725
- Siphon Tube Assembly LRP-96-677

Accessories

- Force Fill Adapter..... LRP-96-704
- Manual Drain..... GRP-96-685
- Sight Gauge Kit..... GRP-96-825
- Wall Mounting Bracket –
 - L-Type GPA-96-604
 - T-Type GPA-96-602

L18 1/4" Lubricator

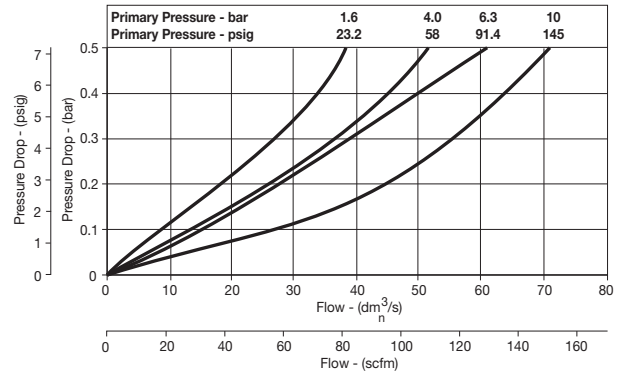

L18 3/8" Lubricator

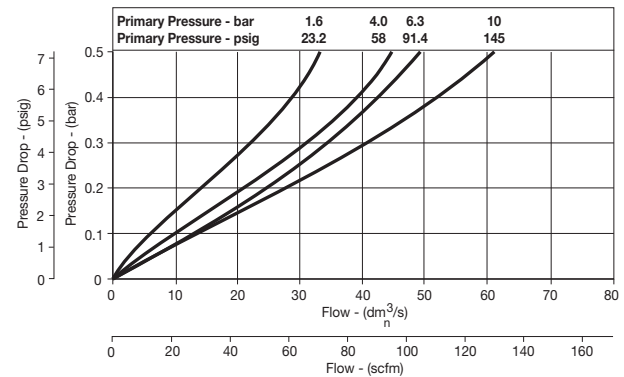

L18 1/2" Lubricator

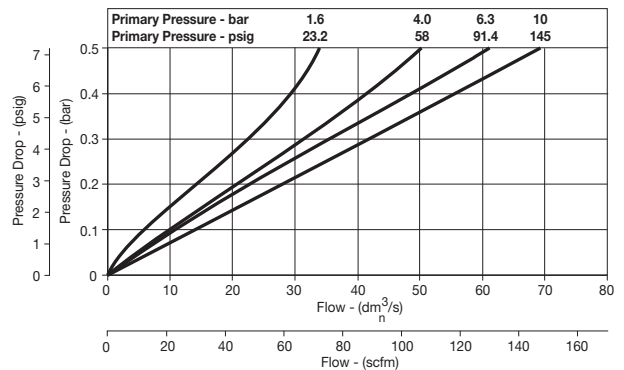

Ordering Information

Model Type	Port Size	Plastic Bowl / Bowl Guard	Metal Bowl / Sight Gauge
No Drain	1/4	L18-02-KC00B	L18-02-KD00B
	3/8	L18-03-KC00B	L18-03-KD00B
	1/2	L18-04-KC00B	L18-04-KD00B
Manual Drain	1/4	L18-02-KK00B	L18-02-KL00B
	3/8	L18-03-KK00B	L18-03-KL00B
	1/2	L18-04-KK00B	L18-04-KL00B

Options - To order an option supplied with the unit model, add the appropriate coded suffix letter in the designated position of the model number.

Lubricator L28 EconOmist™

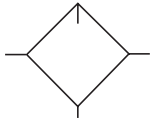

Features

- Integral Sight Dome and Adjustment Knob
- 3/4" NPT / BSPP-G Over-port
- Can be Filled while Under Pressure
- Quick-disconnect Bowl / Bowl Guard
- High Flow Capacities

Specifications

Flow Capacity*	3/8	110 SCFM (52 dm ³ /s, ANR)
	1/2	110 SCFM (52 dm ³ /s, ANR)
	3/4	150 SCFM (71 dm ³ /s, ANR)
Initial Drip Flow	1.26 SCFM	
Maximum Supply Pressure	Plastic Bowl	150 PSIG (10.3 bar)
	Metal Bowl	250 PSIG (17.2 bar)
Minimum Flow for Lubrication	1.3 SCFM @ 100 PSIG	
Operating Temperature	Plastic Bowl	14° to 125°F (-10° to 52°C)
	Metal Bowl	14° to 150°F (-10° to 65.5°C)
Port Size	NPT / BSPP-G	3/8, 1/2, 3/4
Bowl Capacity	6 oz	
Weight	1.04 lb. (0.47 kg)	

* Inlet pressure 91.3 PSIG (6.3 bar). Pressure drop 4.9 PSID (0.34 bar).

Materials of Construction

Body	Aluminum	
Body Cap	ABS	
Bowls	Plastic Bowl	Polycarbonate
	Metal Bowl	Aluminum
Pick-up Filter	Sintered Bronze	
Seals	Plastic Bowl	Nitrile
	Metal Bowl	Nitrile
Sight Dome	Polycarbonate	
Sight Gauge	Metal Bowl	Polyamide (Nylon)
Suggested Lubricant	Airline Oil F442001	

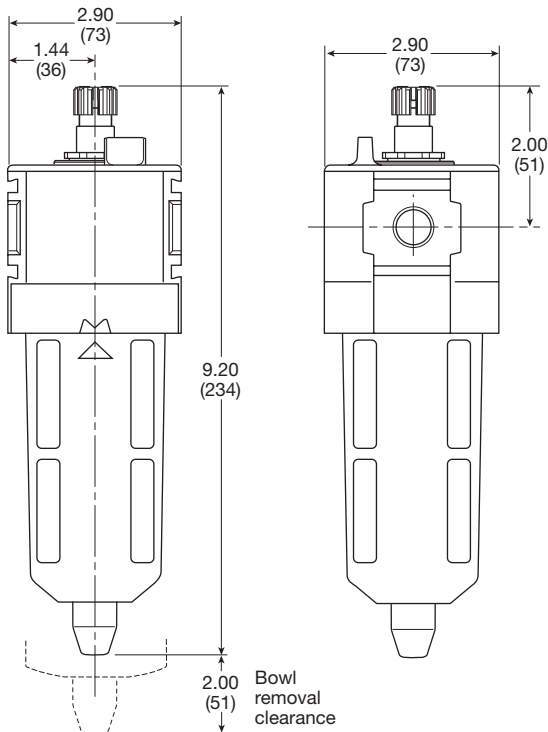

Inches (mm)

= "Most Popular"

Replacement Bowl Kits

- Metal Bowl with Sight Gauge, Manual Drain..... GRP-96-644
- Plastic Bowl / Bowl Guard, Manual Drain..... LRP-96-702

Replacement Kits

- Bowl O-ring, Nitrile..... GRP-96-654
- Bowl O-ring, Fluorocarbon..... GRP-96-755
- Bypass Assembly..... LRP-96-678
- Fill Plug Kit..... LRP-96-679
- Sight Dome Assembly –
 - Nylon..... LRP-96-720
 - Polycarbonate, L28-XX-KK00..... LRP-96-725
- Siphon Tube Assembly..... LRP-96-681

Accessories

- Force Fill Adapter..... LRP-96-704
- Sight Gauge Kit..... GRP-96-825
- Wall Mounting Bracket –
 - L-Type..... GPA-96-605
 - T-Type..... GPA-96-602

L28 3/8" Lubricator

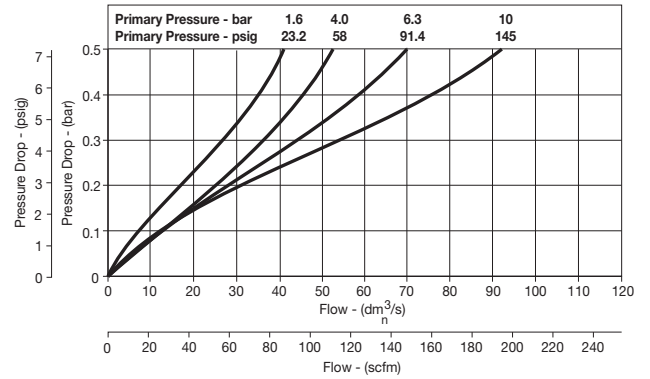

L28 1/2" Lubricator

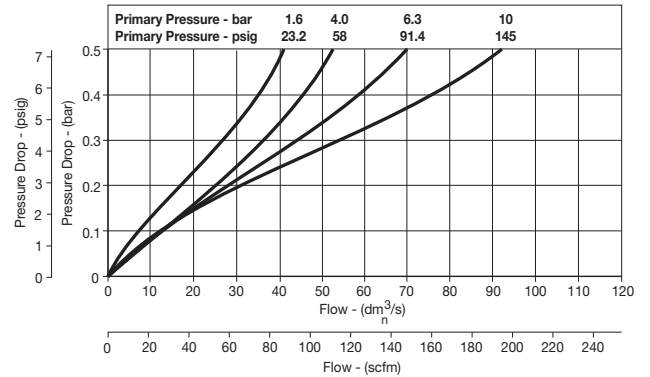

L28 3/4" Lubricator

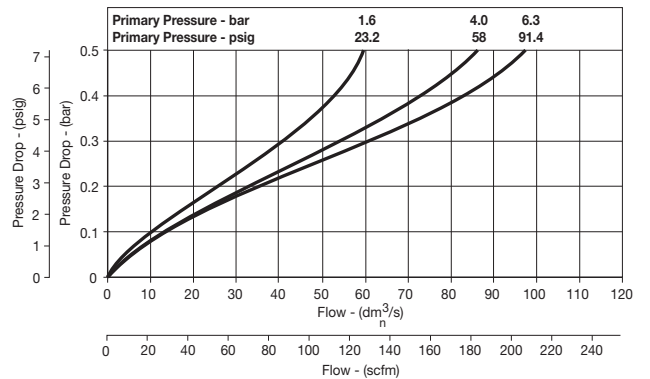

Ordering Information

Model Type	Port Size	Plastic Bowl / Bowl Guard	Metal Bowl / Sight Gauge
No Drain	3/8	L28-03-KC00B	L28-03-KD00B
	1/2	L28-04-KC00B	L28-04-KD00B
	3/4	L28-06-KC00B	L28-06-KD00B
Manual Drain	3/8	L28-03-KK00B	L28-03-KL00B
	1/2	L28-04-KK00B	L28-04-KL00B
	3/4	L28-06-KK00B	L28-06-KL00B

Options - To order an option supplied with the unit model, add the appropriate coded suffix letter in the designated position of the model number.

Lubricator L90



Symbol

 = "Most Popular"

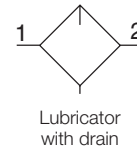

Features

- Integral 3/4" or 1" ports (BSPP & NPT)
- Robust but lightweight aluminum construction
- Proportional oil delivery over a wide range of air flows
- Possible to fill under system pressure eliminating down time
- Large oil reservoir

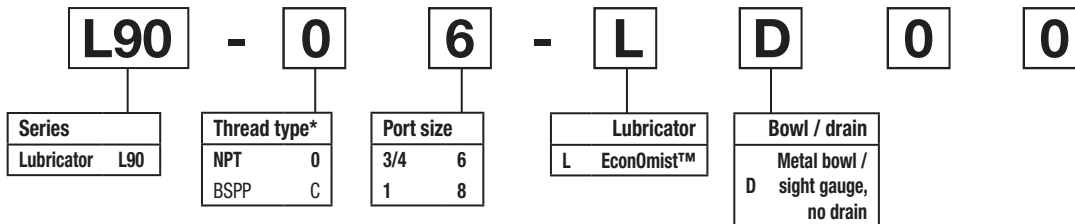

*Note: For 1-1/2" ported unit, please order P3YKA*BCP port block kit separately.
Bold items are most common.

Ordering information

Port size	Description	Flow ‡ scfm	Max. bar (psig)	Min temp °C (°F)	Max temp °C (°F)	Bowl capacity cm ³ (oz)	Height mm (inches)	Width mm (inches)	Depth mm (inches)	Weight kg (lb)	Part number †
3/4"	Oil mist, fill under pressure	315	17.5 (254)	-10 (14)	60 (140)	500 (16.9)	247 (9.7)	90 (3.5)	94 (3.7)	0.8 (1.8)	L90-06-LD00
1"	Oil mist, fill under pressure	390	17.5 (254)	-10 (14)	60 (140)	500 (16.9)	247 (9.7)	90 (3.5)	94 (3.7)	0.8 (1.8)	L90-08-LD00

† Standard part numbers shown in bold. For other models refer to Options chart above.
 ‡ Flow with 6.3 bar (91.4 psig) inlet pressure and 0.5 (7.3 psig) pressure drop.

Specifications

Fluid	Compressed air
Maximum inlet pressure*	17.5 bar (254 psig)
Temperature range*	-10°C to 60°C (14°F to 140°F)

* Air supply must be dry enough to avoid ice formation at temperatures below 2°C (35.6°F).

Low flow start point (lubrication pick-up): at 6.3 bar (91.4 psig) inlet pressure 0.5 dm³/s (1.1 scfm).

Flow with 6.3 bar (91.4 psig) inlet pressure and 0.5 bar (7.3 psig) pressure drop.

Material specifications

Body	Aluminum
Sight glass	Polypropylene
Sight dome	Polyamide
Lubricator cover	ABS
Top & bottom end cap	Glass filled nylon
Bayonet support	Nylon
Seals	Nitrile NBR

Dimensions mm (inches)

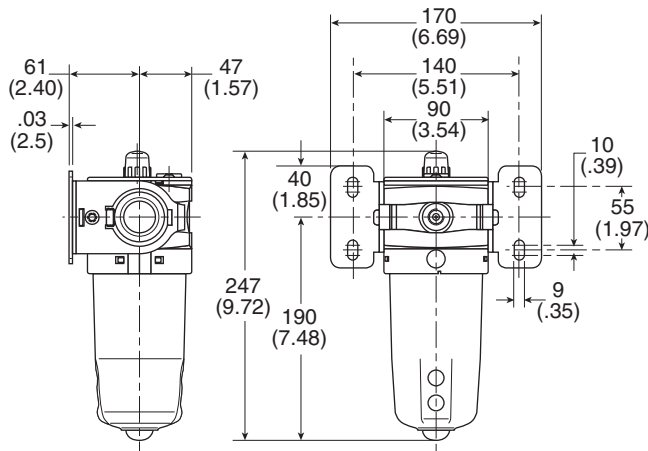

Service kits

Bowl kit.....	P3YKA00BSN
Refill plug	P3YKA00PL
Lubricator oil.....	F442002

Flow characteristics

(3/4") Lubricator

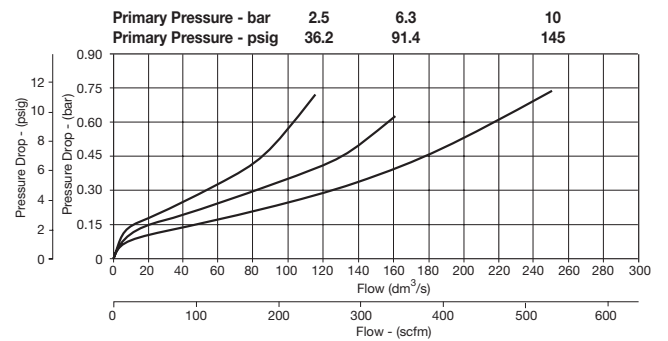

(1") Lubricator

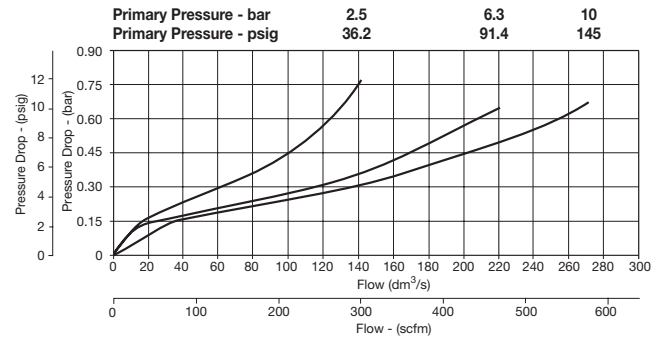

Notes

Filter / Regulator Numbering System

 = "Most Popular"

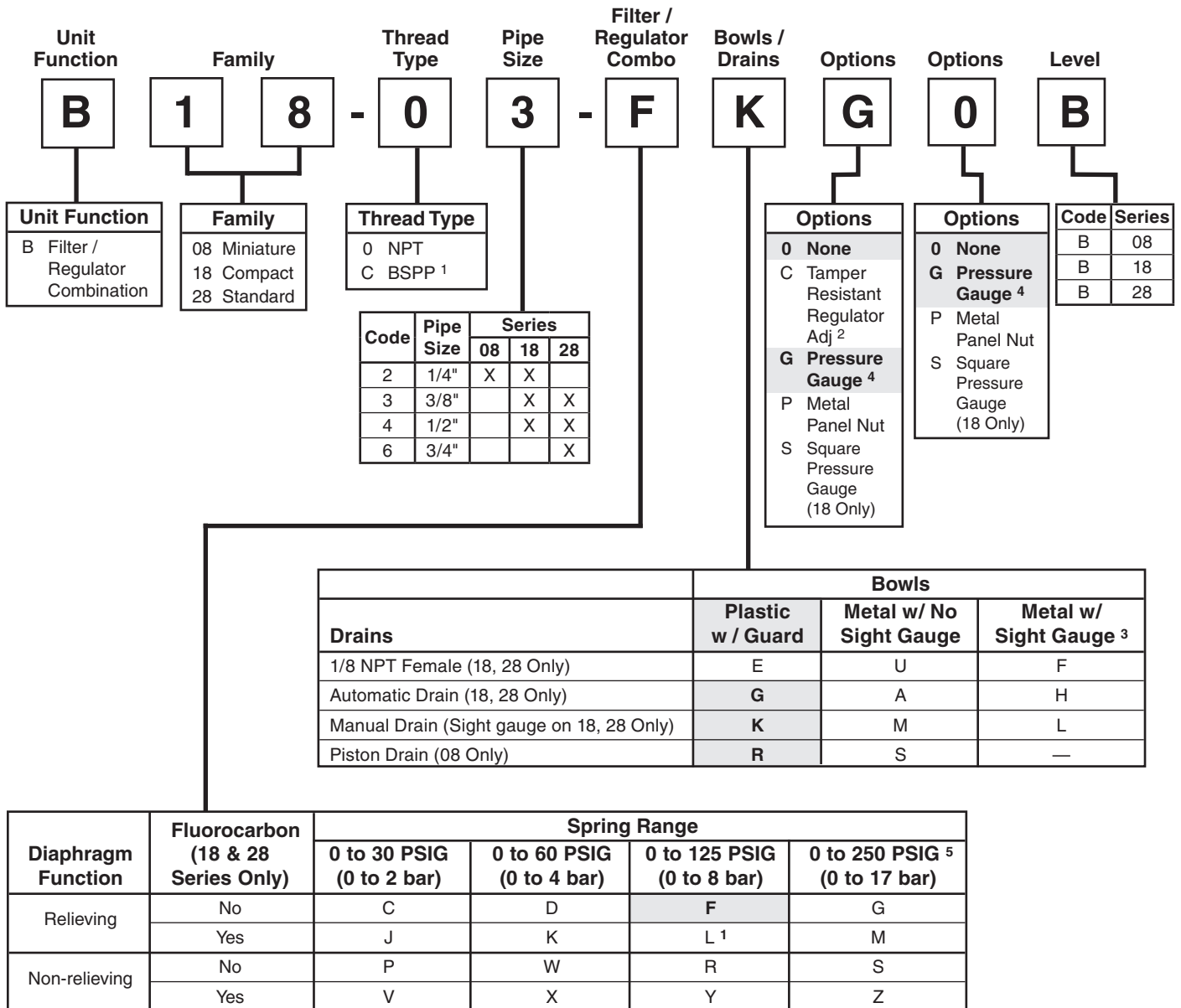

¹ ISO, R228 (G Series).
² Tamper resistant kit not installed. Kit shipped loose in carton, for 08, 18 & 28 Series.
³ B08 Filter / Regulator has an all metal bowl (no sight gauge).
⁴ For 08 Series only: "G" in position 8 or 9 is for unit w/ flush-mounted pressure gauge. Units without gauge have 1/8" threaded gauge ports, and a center back mounted pressure gauge must be ordered separately.
⁵ R08 series operating range 0 to 232 PSIG (1 to 16 bar).

NOTE: When selecting from the options columns, please enter letters in alphabetical order, for positions 7, 8, 9. For example:

B 18-03-F K 0 0 B

"F" Series Filters, Type "A" 5 micron elements: All Wilkerson Type "A" 5 micron elements **meet or exceed ISO** Class 3 for maximum particle size and concentration of solid contaminants.

NOTE:All classes above refer to International Standards Organization (ISO) standard 8573-1, pertaining to maximum particle size and concentration of solid contaminants, and maximum oil content.

Filter / Regulator B08

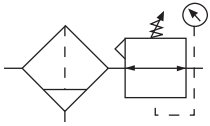

Features

- Space-Saving Integral Filter / Regulator Design
- Unique Flush-mounted Pressure Gauge Available
- Balanced Valve Design
- Modern Design and Appearance
- Light Weight
- High Flow Capacities
- Quick-Disconnect Bowl / Bowl Guard

WARNING

**Product rupture can cause serious injury.
Do not connect regulator to bottled gas.
Do not exceed maximum primary pressure rating.**

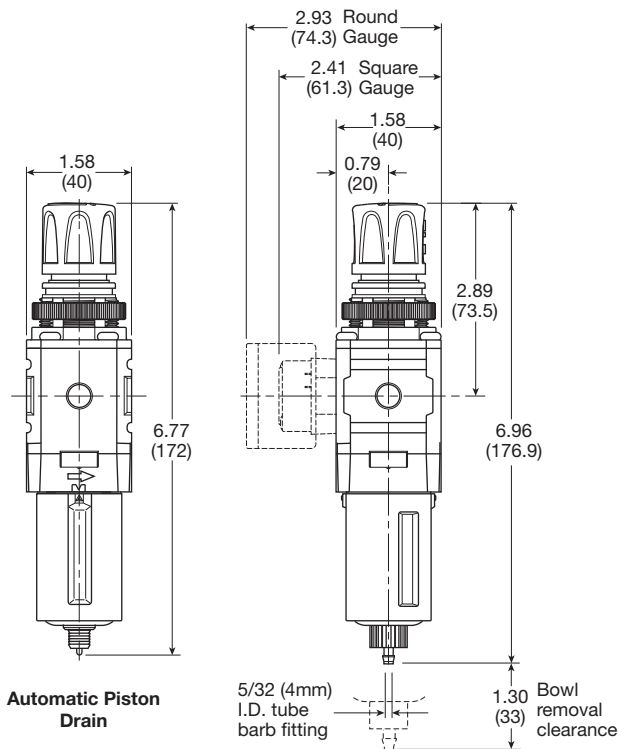

Specifications

Flow Capacity*	1/4	73 SCFM (35 dm ³ /s, ANR)
Adjusting Range Pressure		0 to 30 PSIG (0 to 2 bar)
		0 to 60 PSIG (0 to 4 bar)
		0 to 125 PSIG (0 to 8 bar)
		0 to 232 PSIG (0 to 16 bar)
Gauge Ports (2)**	NPT	1/8
Maximum Supply Pressure	Plastic Bowl	150 PSIG (10.3 bar)
	Metal Bowl	250 PSIG (17.2 bar)
Operating Temperature†	Plastic Bowl	14° to 125°F (-10° to 52°C)
	Metal Bowl	14° to 150°F (-10° to 65.5°C)
Port Size	NPT / BSPP-G	1/4
Bowl Capacity		0.4 oz
Standard Filtration		5 Micron
Weight		0.42 lb. (0.19 kg)

* Inlet pressure 145 psig (10 bar). Secondary pressure 91.3 psig (6.3 bar) and 14.5 psig (1 bar) pressure drop.

** Non-gauge option only.

† Units with square gauges: 5°F to 150°F (-15°C to 65.5°C)

“F” Series Filters, Type “A” 5 micron elements: All Wilkerson Type “A” 5 micron elements **meet or exceed ISO Class 3** for maximum particle size and concentration of solid contaminants.

Air quality: Within ISO 8573-1: 1991 Class 3 (Particulates)
Within ISO 8573-1: 2001 Class 6 (Particulates)

Materials of Construction

Adjustment Knob	Acetal	
Body	Aluminum	
Body Cap	ABS	
Bonnet	PBT	
Bowl	Plastic Bowl	Polycarbonate
	Metal Bowl	Aluminum
Bowl Guard	Nylon	
Diaphragm Assembly	Brass / Nitrile	
Filter Element	Polyethylene	
Panel Nut	Acetal	
Seals	Plastic Bowl	Nitrile
	Metal Bowl	Nitrile
Springs	Steel	
Valve Assembly	Brass / Nitrile	

CAUTION:

REGULATOR PRESSURE ADJUSTMENT – The working range of knob adjustment is designed to permit outlet pressures within their full range. Pressure adjustment beyond this range is also possible because the knob is not a limiting device. This is a common characteristic of most industrial regulators, and limiting devices may be obtained only by special design.

For best performance, regulated pressure should always be set by increasing the pressure up to the desired setting.

Inches (mm)

 = "Most Popular"

Replacement Bowl Kits

- Metal Bowl, Manual Drain..... GRP-96-714
- Plastic Bowl / Bowl Guard, Manual Drain..... GRP-96-712

Replacement Element Kit

- Type "A", 5 Micron FRP-96-729

Replacement Kits

- Adjusting Knob..... RRP-16-005-000
- Diaphragm Assembly –
 - Non-relieving GRP-96-726B
 - Relieving..... GRP-96-725B
- Spring, Regulating –
 - 0 to 125 PSIG (0 to 8.5 bar)..... GRP-96-717B

Accessories

- Automatic Piston Drain GRP-96-716
- Panel Mount Nut –
 - Aluminum..... RPA-96-733
 - Plastic RPA-96-734
- Gauge, Pressure Flush Mounted –
 - 0 to 60 PSIGK4511SCR060
 - 0 to 150 PSIG.....K4511SCR150
 - 0 to 4 bar K4511SCR04B
 - 0 to 11 bar K4511SCR11B
 - 0 to 60 PSIG (0 to 4.1 bar)
 - 1-1/2" Dial Face, 1/8 NPT, CBM.....K4515N18060
 - 0 to 160 PSIG (0 to 11.0 bar)
 - 1-1/2" Dial Face, 1/8 NPT, CBM.....K4515N18160
 - Square with Adapter Kit
 - 0-4 bar P6G-PR10040
 - 0-11 bar..... P6G-PR10110
 - 0-60 psig..... P6G-PR90060
 - 0-160 psig..... P6G-PR90160
- Tamper Resistant Kit..... RPA-96-735
- Tamperproof Lock and Cover Kit..... RPA-96-736
- Wall Mounting Bracket -
 - C-TypeGPA-97-010
 - L-Type.....GRP-96-739

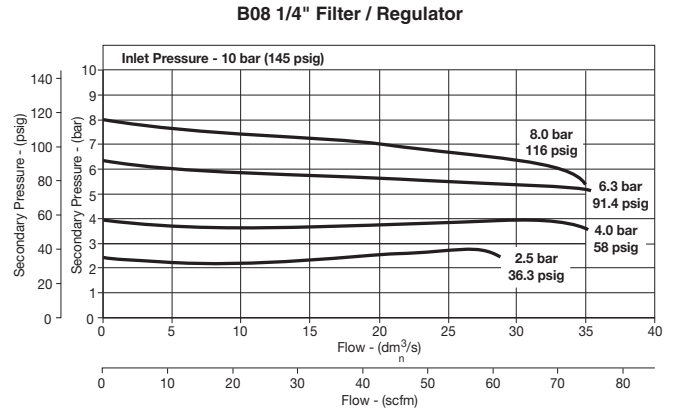

Ordering Information

Model Type	Port Size	Plastic Bowl / Bowl Guard / Manual Drain / Without Gauge 0 to 30 PSIG (0 to 0.2 bar)	Plastic Bowl / Bowl Guard / Manual Drain / Without Gauge 0 to 125 PSIG (0 to 8.6 bar)	Plastic Bowl / Bowl Guard / Manual Drain / With Gauge 0 to 20 PSIG (0 to 2.0 bar)	Plastic Bowl / Bowl Guard / Manual Drain / With Gauge 0 to 125 PSIG (0 to 8.6 bar)	Plastic Bowl / Bowl Guard / Manual Drain / Low Pressure / Without Gauge 0 to 60 PSIG (0 to 4.1 bar)	Plastic Bowl / Bowl Guard / Automatic Piston / With Gauge 0 to 125 PSIG (0 to 8.6 bar)
Relieving	1/4	B08-02-CK00B	B08-02-FK00B	B08-02-CKG0B	B08-02-FKG0B	B08-02-DK00B	B08-02-FRG0B
Non-relieving	1/4	B08-02-PK00B	B08-02-RK00B	B08-02-PKG0B	B08-02-RKG0B	B08-02-WK00B	B08-02-RRG0B

Options - To order an option supplied with the unit model, add the appropriate coded suffix letter in the designated position of the model number.

Filter / Regulator B18

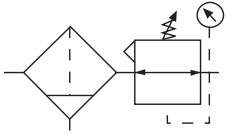

Features

- 5 Micron Filtration
- Balanced Valve Design
- Spring Loaded Diaphragm
- 1/2" NPT / BSPP-G Over-Ported
- Quick-Disconnect Bowl / Bowl Guard
- Light Weight
- High Flow Capacities

⚠ WARNING

**Product rupture can cause serious injury.
Do not connect regulator to bottled gas.
Do not exceed maximum primary pressure rating.**

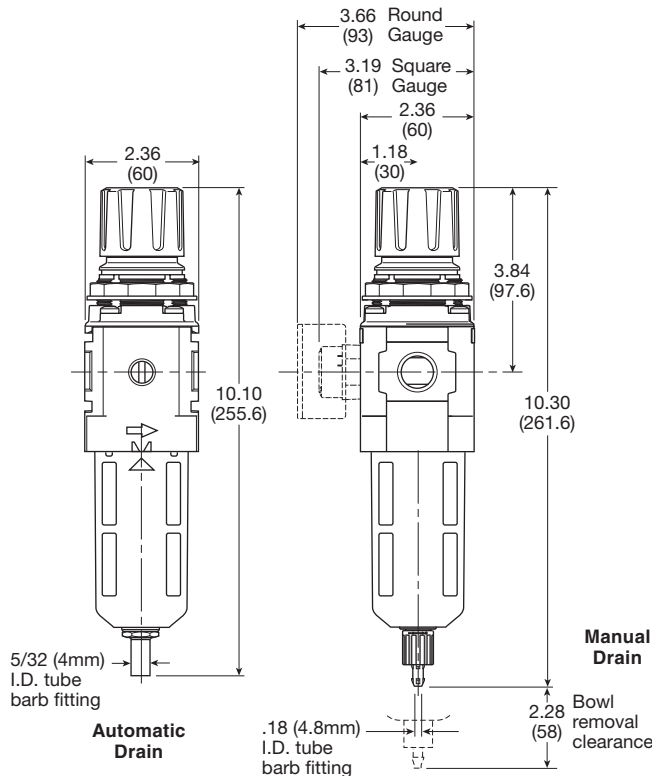

Specifications

Flow Capacity*	1/4	148 SCFM (70 dm ³ /s, ANR)
	3/8	158 SCFM (75 dm ³ /s, ANR)
	1/2	164 SCFM (77 dm ³ /s, ANR)
Adjusting Range Pressure		0 to 30 PSIG (0 to 2 bar)
		0 to 60 PSIG (0 to 4 bar)
		0 to 125 PSIG (0 to 8 bar)
		0 to 250 PSIG (0 to 17 bar)
Gauge Port (2)	NPT / BSPP-G	1/4
Maximum Supply Pressure	Plastic Bowl	150 PSIG (10.3 bar)
	Metal Bowl	250 PSIG (17.2 bar)
Operating Temperature	Plastic Bowl	-13° to 125°F (-25° to 52°C)
	Metal Bowl	-13° to 150°F (-25° to 65.5°C)
Port Size	NPT / BSPP-G	1/4, 3/8, 1/2
Bowl Capacity		1.72 oz
Standard Filtration		5 Micron
Weight		1.17 lb. (0.53 kg)

* Inlet pressure 145 psig (10 bar). Secondary pressure 91.3 psig (6.3 bar) and 14.5 psig (1 bar) pressure drop.

"F" Series Filters, Type "A" 5 micron elements: All Wilkerson Type "A" 5 micron elements **meet or exceed ISO Class 3** for maximum particle size and concentration of solid contaminants.

Air quality: Within ISO 8573-1: 1991 Class 3 (Particulates)
Within ISO 8573-1: 2001 Class 6 (Particulates)

Materials of Construction

Adjustment Knob	Acetal	
Body	Aluminum	
Body Cap	ABS	
Bowl	Plastic Bowl	Polycarbonate
	Metal Bowl	Aluminum
Bowl Guard	Nylon	
Diaphragm Assembly	Nitrile / Steel	
Element Retainer / Baffle	Acetal	
Filter Element	Sintered Polyethylene	
Panel Nut	Acetal	
Seals	Plastic Bowl	Nitrile
	Metal Bowl	Nitrile
Sight Gauge	Metal Bowl	Polyamide (Nylon)
Springs	Main Regulating / Valve	Steel / S.S.
Valve Assembly	Brass / Nitrile	

CAUTION:

REGULATOR PRESSURE ADJUSTMENT – The working range of knob adjustment is designed to permit outlet pressures within their full range. Pressure adjustment beyond this range is also possible because the knob is not a limiting device. This is a common characteristic of most industrial regulators, and limiting devices may be obtained only by special design.

For best performance, regulated pressure should always be set by increasing the pressure up to the desired setting.

Inches (mm)

= "Most Popular"

Replacement Bowl Kits

- Metal Bowl –
 - Sight Gauge, Automatic Drain GRP-96-637
 - Sight Gauge, Manual Drain..... GRP-96-636
- Plastic Bowl –
 - Bowl Guard, Automatic Drain..... GRP-96-635
 - Bowl Guard, Manual Drain..... GRP-96-634

Replacement Element Kits

- Type "A", 5 Micron FRP-96-639
- Retainer, Deflector, and Element Kit FRP-96-641

Replacement Kits

- Adjusting Knob RRP-16-340-000
- Diaphragm Assembly –
 - Non-relieving RRP-96-657B
 - Relieving..... RRP-96-656B
- Spring, Regulating –
 - 0 to 30 PSIG (0 to 2.1 bar) RRP-96-659B
 - 0 to 60 PSIG (0 to 4.1 bar) RRP-96-660B
 - 0 to 125 PSIG (0 to 8.6 bar) RRP-96-661B
 - 0 to 250 PSIG (0 to 17.2 bar) RRP-96-662B

Accessories

- Automatic Drain –
 - Fluorocarbon..... GRP-95-981
 - Nitrile..... GRP-95-973
- Drain, Manual Override GRP-96-000
- Manual Drain GRP-96-685
- Panel Mount Nut –
 - Aluminum..... RRP-96-673
 - Plastic RRP-96-675B
- Gauge, Pressure –
 - 50mm (2") round 1/4" center back mount
 - 0-30 PSIG / 0-2 bar K4520N14030
 - 0-60 PSIG / 0-4 bar K4520N14060
 - 0-160 PSIG / 0-11 bar K4520N14160
 - 0-300 PSIG / 0-20 bar K4520N14300
 - 0 to 160 PSIG, 1-3/4" Digital Round, 1/4" NPT..... K4517N14160D
- Tamper Resistant Kit..... RRP-96-671
- Tamperproof Lock & Cover Kit..... RPA-96-736
- Sight Gauge Kit..... GRP-96-825
- Wall Mounting Bracket
 - L-Type (Body)..... GPA-96-604
 - L-Type (Bonnet)..... GPA-96-606
 - T-Type GPA-96-602

B08 1/4" Filter / Regulator

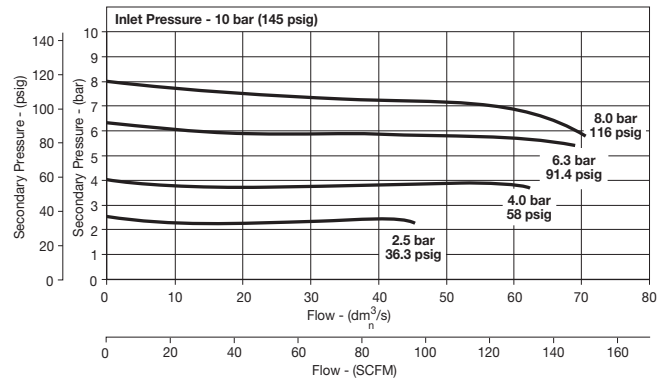

B18 3/8" Filter / Regulator

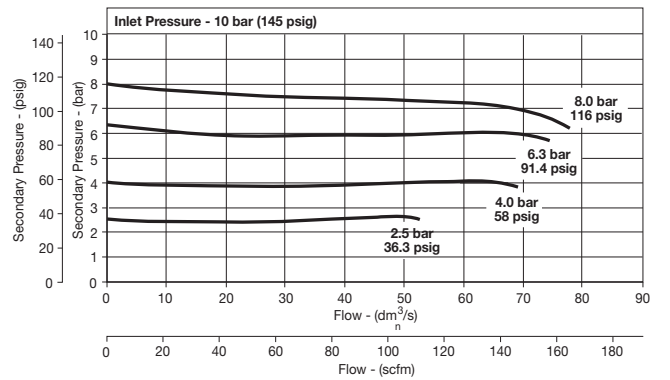

B08 1/2" Filter / Regulator

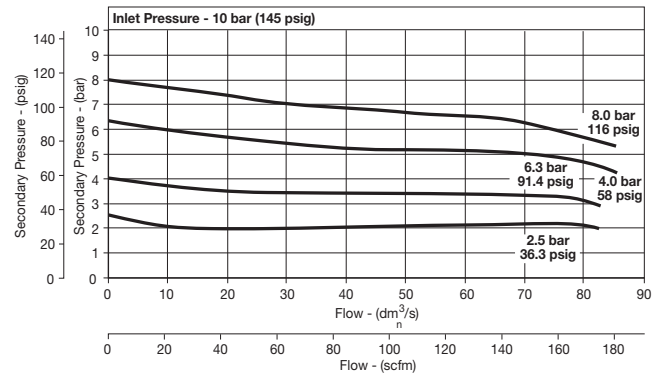

Ordering Information

Model Type	Port Size	Plastic Bowl / Bowl Guard With Gauge 5 to 125 PSIG (0.4 to 8.6 bar)	Metal Bowl / Sight Gauge With Gauge 5 to 125 PSIG (0.4 to 8.6 bar)
Manual Drain	1/4	B18-02-FKG0B	B18-02-FLG0B
	3/8	B18-03-FKG0B	B18-03-FLG0B
	1/2	B18-04-FKG0B	B18-04-FLG0B
Automatic Drain	1/4	B18-02-FGG0B	B18-02-FHG0B
	3/8	B18-03-FGG0B	B18-03-FHG0B
	1/2	B18-04-FGG0B	B18-04-FHG0B

Options - To order an option supplied with the unit model, add the appropriate coded suffix letter in the designated position of the model number.

Filter / Regulator B28

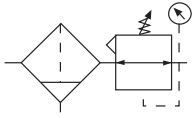

Features

- 5 Micron Filtration
- Balanced Valve Design
- Spring Loaded Diaphragm
- 3/4" NPT / BSPP-G Over-Ported
- Quick-Disconnect Bowl / Bowl Guard
- Light Weight
- High Flow Capacities

⚠ WARNING

**Product rupture can cause serious injury.
Do not connect regulator to bottled gas.
Do not exceed maximum primary pressure rating.**

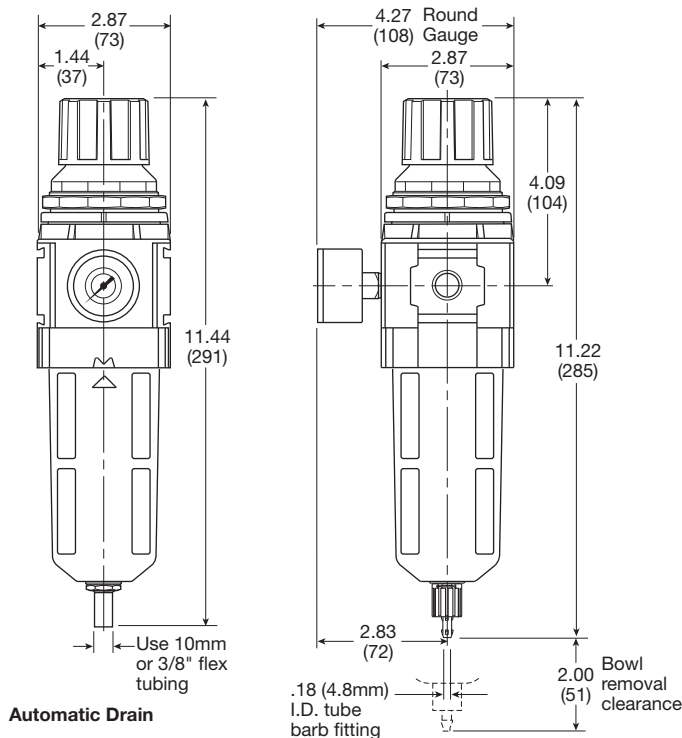

Inches (mm)

Specifications

Flow Capacity*	3/8	200 SCFM (94 dm ³ /s, ANR)
	1/2	200 SCFM (94 dm ³ /s, ANR)
	3/4	235 SCFM (109 dm ³ /s, ANR)
Adjusting Range Pressure		0 to 30 PSIG (0 to 2.1 bar)
		0 to 60 PSIG (0 to 4.1 bar)
		0 to 125 PSIG (0 to 8.6 bar)
		0 to 250 PSIG (0 to 17.2 bar)
Gauge Port (2)	NPT / BSPP-G	1/4
Maximum Supply Pressure	Plastic Bowl	150 PSIG (10.3 bar)
	Metal Bowl	250 PSIG (17.2 bar)
Operating Temperature	Plastic Bowl	-13° to 125°F (-25° to 52°C)
	Metal Bowl	-13° to 150°F (-25° to 65.5°C)
Port Size	NPT / BSPP-G	3/8, 1/2, 3/4
Bowl Capacity		2.87 oz
Standard Filtration		5 Micron
Weight		1.87 lb. (0.85 kg)

* Inlet pressure 145 psig (10 bar). Secondary pressure 91.3 psig (6.3 bar) and 14.5 psig (1 bar) pressure drop.

“F” Series Filters, Type “A” 5 micron elements: All Wilkerson Type “A” 5 micron elements **meet or exceed** ISO Class 3 for maximum particle size and concentration of solid contaminants.

Air quality: Within ISO 8573-1: 1991 Class 3 (Particulates)
Within ISO 8573-1: 2001 Class 6 (Particulates)

Materials of Construction

Adjustment Knob		Acetal
Body		Aluminum
Body Cap		ABS
Bowls	Plastic Bowl	Polycarbonate
	Metal Bowl	Aluminum
Diaphragm Assembly		Nitrile / Zinc
Element Retainer / Baffle		Acetal
Filter Element		Sintered Polyethylene
Panel Nut		Acetal
Seals	Plastic Bowl	Nitrile
	Metal Bowl	Nitrile
Sight Gauge	Metal Bowl	Polyamide (Nylon)
Springs	Main Regulating / Valve	Steel / S.S.
Valve Assembly		Brass / Nitrile

CAUTION:

REGULATOR PRESSURE ADJUSTMENT – The working range of knob adjustment is designed to permit outlet pressures within their full range. Pressure adjustment beyond this range is also possible because the knob is not a limiting device. This is a common characteristic of most industrial regulators, and limiting devices may be obtained only by special design.

For best performance, regulated pressure should always be set by increasing the pressure up to the desired setting.

= "Most Popular"

Replacement Bowl Kits

- Metal Bowl –
 - Sight Gauge, Automatic Drain GRP-96-645
 - Sight Gauge, Manual Drain..... GRP-96-644
- Plastic Bowl –
 - Bowl Guard, Automatic Drain..... GRP-96-643
 - Bowl Guard, Manual Drain..... GRP-96-642

Replacement Element Kits

- Type " A", 5 Micron..... FRP-96-653
- Element, Deflector, Retainer kit..... FRP-96-283

Replacement Kits

- Adjusting Knob..... RRP-16-341-000
- Diaphragm Assembly –
 - Non-relieving..... RRP-96-987
 - Relieving..... RRP-96-986
- Spring, Regulating –
 - 0 to 30 PSIG (0 to 2.1 bar)..... RRP-96-163
 - 0 to 60 PSIG (0 to 4.1 bar)..... RRP-96-164
 - 0 to 125 PSIG (0 to 8.6 bar)..... RRP-96-165
 - 0 to 250 PSIG (0 to 17.2 bar)..... RRP-96-166
- Valve Assembly..... RRP-96-049

Accessories

- Automatic Drain –
 - Fluorocarbon GRP-95-981
 - Nitrile GRP-95-973
- Manual Drain..... GRP-96-685
- Panel Mount Nut –
 - Aluminum..... RRP-96-674
 - Plastic..... RRP-96-676
- Gauge, Pressure –
 - 50mm (2") round 1/4" center back mount
 - 0-30 PSIG / 0-2 barK4520N14030
 - 0-60 PSIG / 0-4 barK4520N14060
 - 0-160 PSIG / 0-11 barK4520N14160
 - 0-300 PSIG / 0-20 barK4520N14300
 - 0 to 160 PSIG, 1-3/4" Digital Round, 1/4" NPTK4517N14160D
- Tamper Resistant Kit..... RRP-96-672
- Sight Gauge Kit..... GRP-96-825
- Wall Mounting Bracket –
 - L-Type (Body)GPA-96-605
 - L-Type (Bonnet).....GPA-96-607
 - T-Type GPA-96-602

B28 3/8" Filter / Regulator

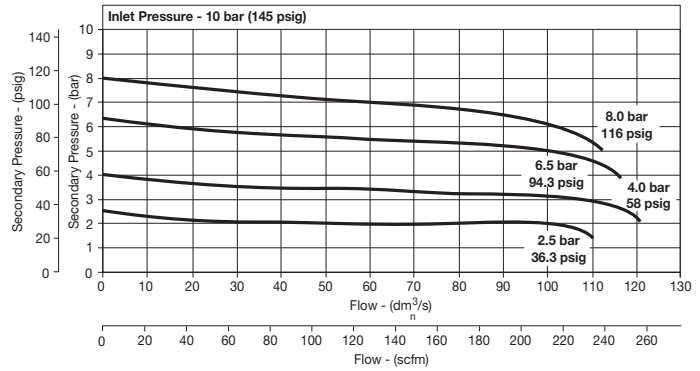

B28 1/2" Filter / Regulator

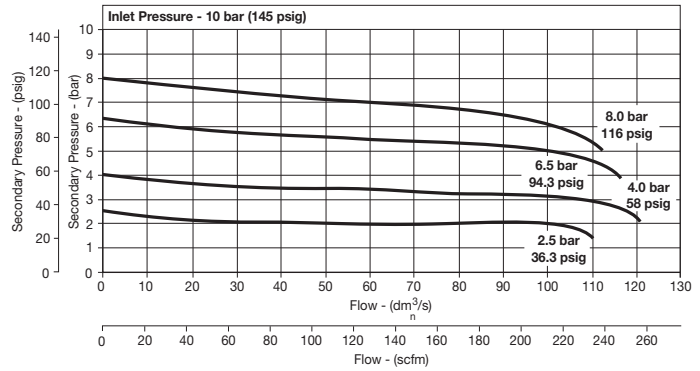

B18 3/8" Filter / Regulator

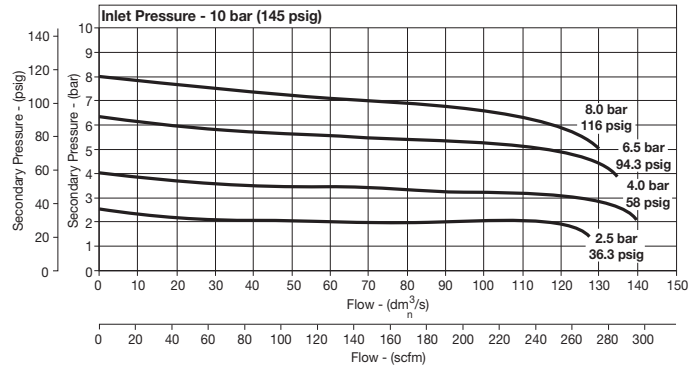

Ordering Information

Model Type	Port Size	Plastic Bowl / Bowl Guard With Gauge 5 to 125 PSIG (0.4 to 8.6 bar)	Metal Bowl / Sight Gauge With Gauge 5 to 125 PSIG (0.4 to 8.6 bar)
Manual Drain	3/8	B28-03-FKGOB	B28-03-FLGOB
	1/2	B28-04-FKGOB	B28-04-FLGOB
	3/4	B28-06-FKGOB	B28-06-FLGOB
Automatic Drain	3/8	B28-03-FGGOB	B28-03-FHGOB
	1/2	B28-04-FGGOB	B28-04-FHGOB
	3/4	B28-06-FGGOB	B28-06-FHGOB

Options - To order an option supplied with the unit model, add the appropriate coded suffix letter in the designated position of the model number.

Filter / Regulator B90



Symbols

= "Most Popular"

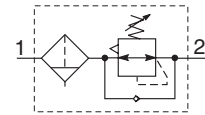
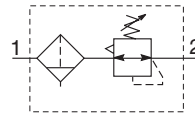

Features

- Integral 3/4" or 1" ports (BSPP or NPT)
- High efficiency element as standard
- Excellent water removal efficiency
- Robust but lightweight aluminum construction
- Secondary pressure ranges 12 and 16 bar
- Rolling diaphragm for extended life
- Secondary aspiration plus balanced poppet provides quick response and accurate pressure regulation
- Reverse flow / relieving option
- Low temperature -40° with combined manual / semi-auto drain as standard

B90	-	0	6	-	A	H	0	0
Series		Thread type*	Port size		Function / pressure range	Bowl / drain type	Option	
Filter / Regulator Combination B90		NPT 0 BSPP C	3/4 6 1 8		A Relieving / 0 to 174 PSI H Relieving / 0 to 232 PSI	Metal bowl / sight gauge & auto drain H Metal bowl / sight gauge / manual & semi auto drain L	0 None G Pressure Gauge A† Lockable type	

Notes:
 * For 1-1/2" ported unit, please order P3YKA*BCP port block kit separately.
 † Not field convertible.

Bold items are most common.

Ordering information

Port size	Description	Flow ‡ scfm	Max. bar (psig)	Min temp °C (°F)	Max temp °C (°F)	Bowl capacity cm ³ (oz)	Height mm (inches)	Width mm (inches)	Depth mm (inches)	Weight kg (lb)	Part number †
3/4"	12 bar, relieving, combined manual / semi auto drain	335	17.5 (254)	-40 (-40)	60 (140)	130 (4.4)	345 (13.5)	90 (3.5)	94 (3.7)	1.5 (3.3)	B90-06-AL00
3/4"	12 bar, relieving, auto drain	335	17.5 (254)	-10 (14)	60 (140)	130 (4.4)	345 (13.5)	90 (3.5)	94 (3.7)	1.5 (3.3)	B90-06-AH00
3/4"	12 bar, relieving, gauge, combined manual / semi auto drain	335	17.5 (254)	-10 (14)	60 (140)	130 (4.4)	345 (13.5)	90 (3.5)	94 (3.7)	1.5 (3.3)	B90-06-ALG0
3/4"	12 bar, relieving, gauge, auto drain	335	17.5 (254)	-10 (14)	60 (140)	130 (4.4)	345 (13.5)	90 (3.5)	94 (3.7)	1.5 (3.3)	B90-06-AHG0
1"	12 bar, relieving, combined manual / semi auto drain	465	17.5 (254)	-40 (-40)	60 (140)	130 (4.4)	345 (13.5)	90 (3.5)	94 (3.7)	1.5 (3.3)	B90-08-AL00
1"	12 bar, relieving, auto drain	465	17.5 (254)	-10 (14)	60 (140)	130 (4.4)	345 (13.5)	90 (3.5)	94 (3.7)	1.5 (3.3)	B90-08-AH00
1"	12 bar, relieving, gauge, combined manual / semi auto drain	465	17.5 (254)	-10 (14)	60 (140)	130 (4.4)	345 (13.5)	90 (3.5)	94 (3.7)	1.5 (3.3)	B90-08-ALG0
1"	12 bar, relieving, gauge, auto drain	465	17.5 (254)	-10 (14)	60 (140)	130 (4.4)	345 (13.5)	90 (3.5)	94 (3.7)	1.5 (3.3)	B90-08-AHG0

† **Standard part numbers shown in bold. For other models refer to Options chart above.**

‡ Flow with 10 bar (145 psig) inlet pressure, 6.3 bar (91.4 psig) set pressure and 1 bar (14.5 psig) pressure drop.

Lockable regulators will require key lock kit (opposite page).

Specifications

Fluid	Compressed air	
Maximum inlet pressure*	17.5 bar (254 psig)	
Temperature range*:		
Auto drain	-10°C to 60°C (14°F to 140°F)	
Combined drain	-40°C to 60°C (-40°F to 140°F)	
Particle removal	5 micron	
Air quality	Within ISO 8573-1: 1991 Class 3 and 5 (particulates) Within ISO 8573-1: 2001 Class 6 and 7 (particulates)	
Typical flow with 10 bar (145 psig) inlet pressure and 6.3 bar (91 psig) set pressure and 0.5 bar (7.3 psig) pressure drop	1" size 465 scfm	
Manual / semi-auto drain	Closed at 0.8 bar (11.6 psig) G1/8 thread male	
Auto drain bowl pressure to close drain	0.8 bar (11.6 psig)	
Operating range manual override facility	0.8 bar (11.6 psig) to 17.5 bar (254 psig)	
Bowl capacity	130 cm ³ (4.4 US oz)	
Gauge ports (x2)	1/4"	

* Air supply must be dry enough to avoid ice formation at temperatures below 2°C (35.6°F).

Material specifications

Body	Aluminum	
Sight glass	Polypropylene	
Body cover	ABS	
Element	Sintered polypropylene	
Seals	Nitrile NBR	
Drains	Manual / semi-auto:	Acetal
	Automatic:	PA / Ø 10mm brass connection
Bonnet	Glass filled polyamide	
Control knob	Glass filled polyamide	
Valve	Brass / NBR	
Screws	Steel / zinc plated	

CAUTION:

REGULATOR PRESSURE ADJUSTMENT – The working range of knob adjustment is designed to permit outlet pressures within their full range. Pressure adjustment beyond this range is also possible because the knob is not a limiting device. This is a common characteristic of most industrial regulators, and limiting devices may be obtained only by special design.

For best performance, regulated pressure should always be set by increasing the pressure up to the desired setting.

Dimensions mm (inches)

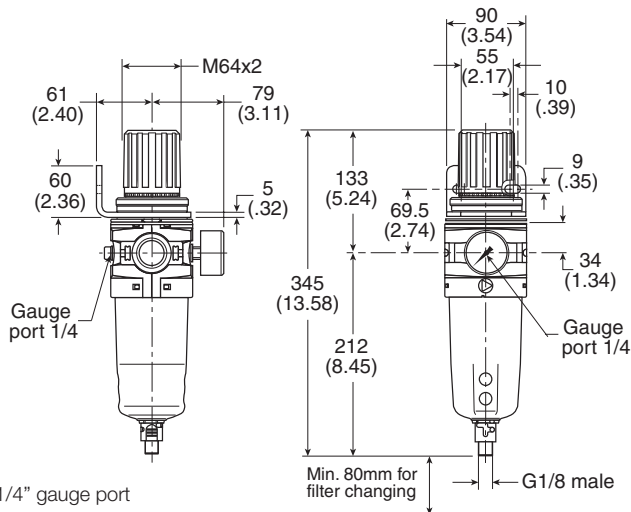

* 1/4" gauge port

Service kits

- 5 micron element kit.....P3YKA00ESE
- Bowl kit
 - Manual/semi auto drain (combined) P3YKA00BSC
 - Auto drainP3YKA00BSA
- Key lock kit..... P3XKA00AS
- Diaphragm kit
 - Relieving type.....P3YKA00RR
 - Non-relieving typeP3YKA00RN
- Angle bracket + metal lock ring P3YKA00MS
- Panel mount nut.....P3YKA00MM

Flow characteristics

(3/4") 5 Micron Filter / Regulator

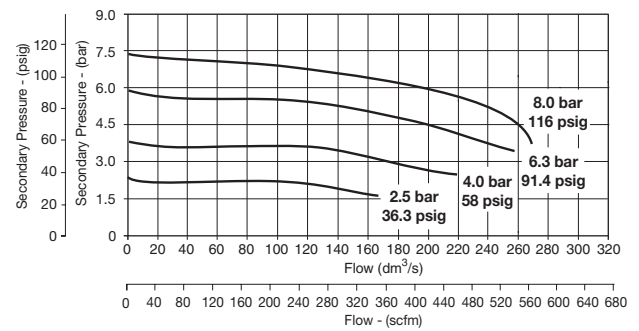

(1") 5 Micron Filter / Regulator

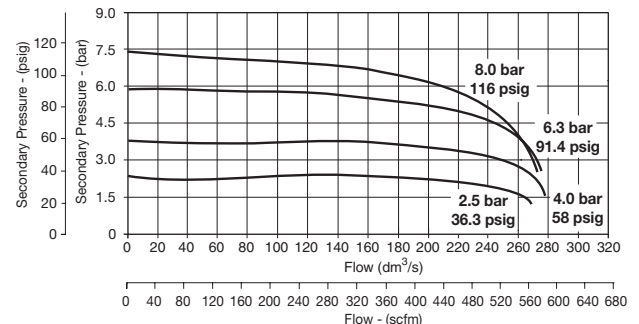

Notes

Filter / Regulator-Lubricator Numbering System

 = "Most Popular"

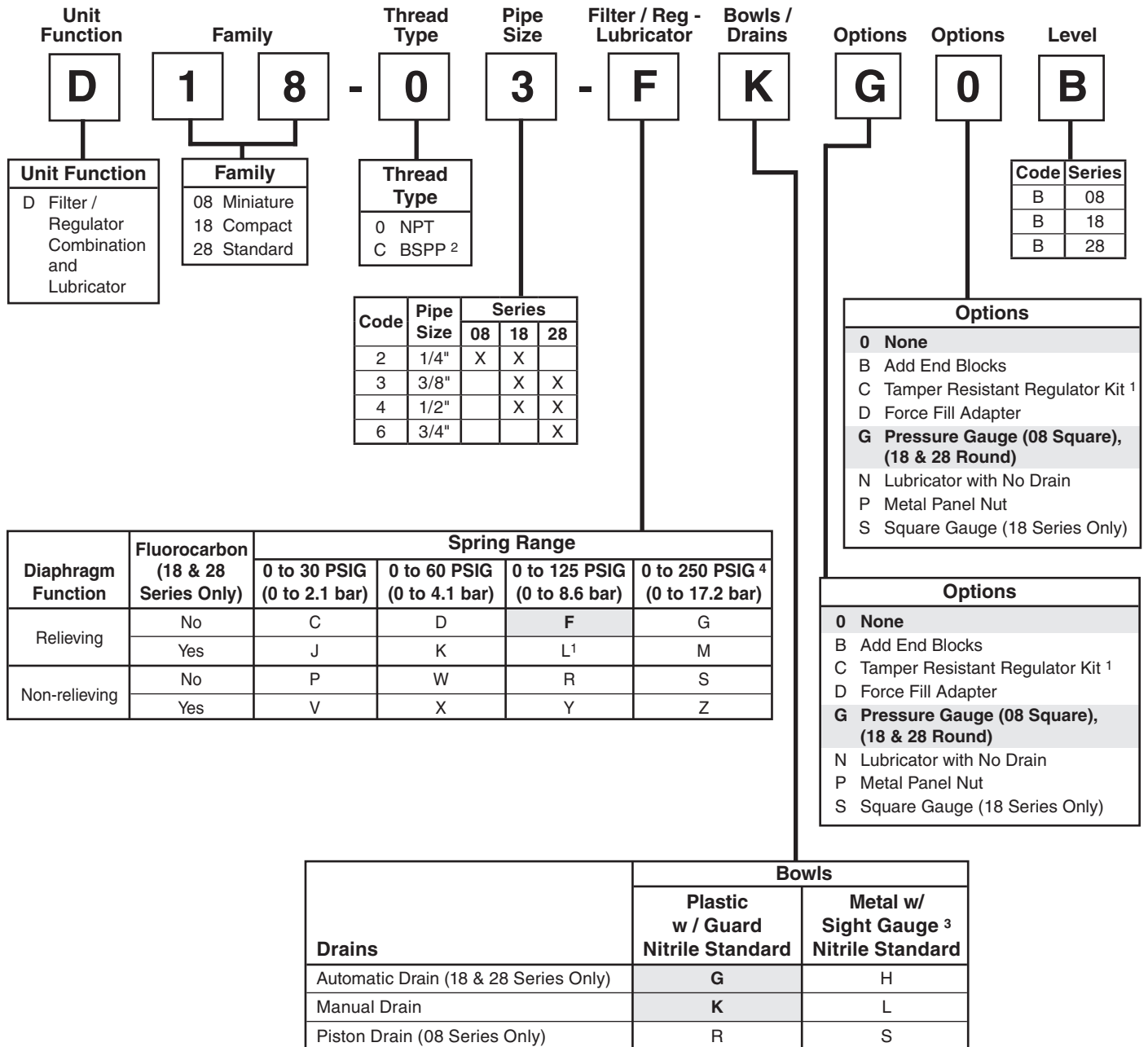

1 Tamper resistant kit not installed. Kit shipped loose in carton.
 2 ISO, R228 (G Series).
 3 08 series has all metal bowl (no sight gauge).
 4 08 series operating range 0 to 232 PSIG (1 to 16 bar).

NOTE: When selecting from the options columns, please enter letters in alphabetical order for positions 7, 8, 9. For example:

D 1 8 - 0 3 - F K G 0 B
 Rev.

"F" Series Filters, Type "A" 5 micron elements: All Wilkerson Type "A" 5 micron elements meet or exceed ISO Class 3 for maximum particle size and concentration of solid contaminants.

Note: All classes above refer to International Standards Organization (ISO) standard 8573-1, pertaining to maximum particle size and concentration of solid contaminants, and maximum oil content.

Combination D08

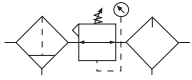

Features

- Components Integrated into Single Unit
- Modern Design and Appearance
- Light Weight, Ready-to-Mount Assembly Comes Standard with Flush-Mount Pressure Gauge and Modular T-Bracket / Joiner Assembly
- High Flow Capacity
- Quick-Disconnect Bowl / Bowl Guard

Specifications

Flow Capacity*	1/4	28 SCFM (14 dm ³ /s, ANR)
Gauge Port (2)**	NPT	1/8
Maximum Supply Pressure	Plastic Bowl	150 PSIG (10.3 bar)
	Metal Bowl	250 PSIG (17.2 bar)
Operating Temperature	Plastic Bowl	14° to 125°F (-10° to 52°C)
	Metal Bowl	14° to 150°F (-10° to 65.5°C)
Port Size	NPT / BSPP-G	1/4
Standard Filtration	5 Micron	
Weight	1.43 lb. (0.6 kg)	

* Inlet pressure 145 PSIG (10 bar), Secondary pressure 91.3 PSIG (6.3 bar), 14.5 PSIG (1 bar) pressure drop.

** Non-gauge option only.

“F” Series Filters, Type “A” 5 micron elements: All Wilkerson Type “A” 5 micron elements **meet or exceed ISO Class 3** for maximum particle size and concentration of solid contaminants.

Materials of Construction

Body	Aluminum	
Bonnet	PBT	
Bowls	Plastic Bowl	Polycarbonate
	Metal Bowl	Aluminum
Diaphragm Assembly	Brass / Nitrile	
Filter Element	Polyethylene	
Knob	Acetal	
Seals	Plastic Bowl	Nitrile
	Metal Bowl	Nitrile
Sight Dome	Polycarbonate	
Springs	Steel	
Suggested Lubricant	Airline Oil F442001	
Valve	Brass / Nitrile	

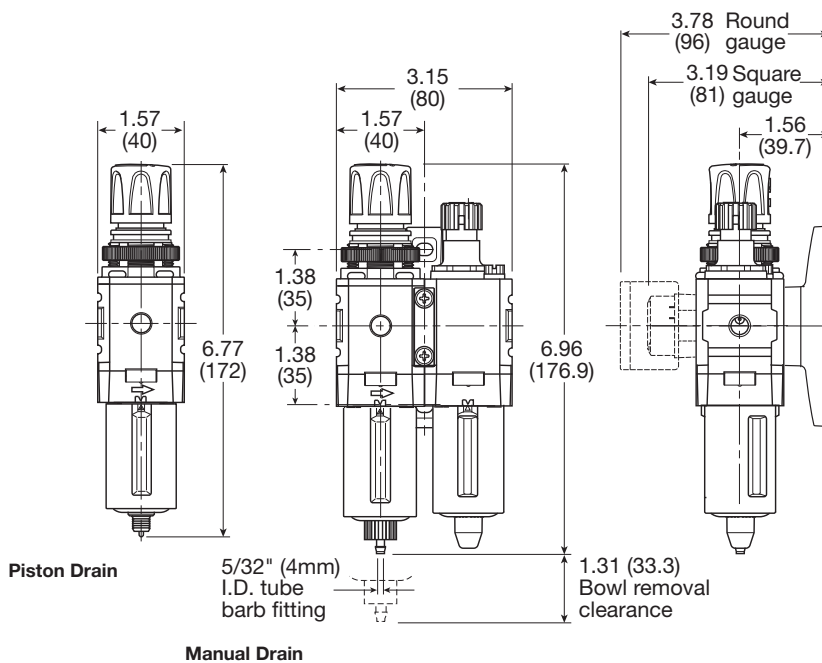

Inches (mm)

Manual Drain

 = "Most Popular"

Note: For Kits and Repair Parts, see individual pages for Filters, Regulators, and Lubricators.

 WARNING
<p>Product rupture can cause serious injury. Do not connect regulator to bottled gas. Do not exceed maximum primary pressure rating.</p>

CAUTION:

REGULATOR PRESSURE ADJUSTMENT – The working range of knob adjustment is designed to permit outlet pressures within their full range. Pressure adjustment beyond this range is also possible because the knob is not a limiting device. This is a common characteristic of most industrial regulators, and limiting devices may be obtained only by special design.

For best performance, regulated pressure should always be set by increasing the pressure up to the desired setting.

Ordering Information

Model	Port Size	Plastic Bowl w / Plastic Bowl Guard 0 to 125 PSI (0 to 8.6 bar) Without Gauge	Plastic Bowl w / Plastic Bowl Guard 0 to 125 PSI (0 to 8.6 bar) With Gauge	Metal Bowl 0 to 125 PSI (0 to 8.6 bar) Without Gauge	Metal Bowl w / 0 to 125 PSI (0 to 8.6 bar) With Gauge
Manual Drain	1/4	D08-02-FK00B	D08-02-FKG0B	D08-02-FL00B	D08-02-FLG0B

Options - To order an option supplied with the unit model, add the appropriate coded suffix letter in the designated position of the model number.

Combination D18

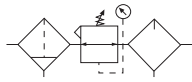

Specifications

Flow Capacity*	1/4	45 SCFM (22 dm ³ /s, ANR)
	3/8	70 SCFM (33 dm ³ /s, ANR)
	1/2	90 SCFM (43 dm ³ /s, ANR)
Gauge Port (2)	NPT / BSPP-G 1/4	
Maximum Supply Pressure	Plastic Bowl	150 PSIG (10.3 bar)
	Metal Bowl	250 PSIG (17.2 bar)
Operating Temperature	Plastic Bowl	-13° to 125°F (-25° to 52°C)
	Metal Bowl	-13° to 150°F (-25° to 65.5°C)
Port Size	NPT / BSPP-G 1/4, 3/8, 1/2	
Standard Filtration	5 Micron	
Weight	2.98 lb. (1.3 kg)	

* Inlet pressure 145 PSIG (10 bar), Secondary pressure 91.3 PSIG (6.3 bar), 14.5 PSIG (1 bar) pressure drop.

“F” Series Filters, Type “A” 5 micron elements: All Wilkerson Type “A” 5 micron elements **meet or exceed ISO Class 3** for maximum particle size and concentration of solid contaminants.

Features

- Components Integrated into Single Unit
- Modern Design and Appearance
- Light Weight, Ready-to-Mount Assembly Comes Standard with Pressure Gauge and Modular T-Bracket / Joiner Assembly
- High Flow Capacity
- Quick-Disconnect Bowl / Bowl Guard

Materials of Construction

Body	Aluminum	
Body Cap	ABS	
Bonnet / Knob	Nylon / Acetal	
Bowls	Plastic Bowl	Polycarbonate
	Metal Bowl	Aluminum
Diaphragm Assembly	Nitrile / Steel	
Element Retainer / Baffle and Deflector	Acetal	
	Polypropylene	
Filter Element	5 micron	Polyethylene
Seals	Plastic Bowl	Nitrile
	Metal Bowl	Nitrile
Sight Dome	Polycarbonate	
Sight Gauge	Polyamide (Nylon)	
Springs	Main Regulating	Steel
	Valve	Stainless Steel
Suggested Lubricant	Airline Oil F442001	
Valve Assembly	Brass / Nitrile	

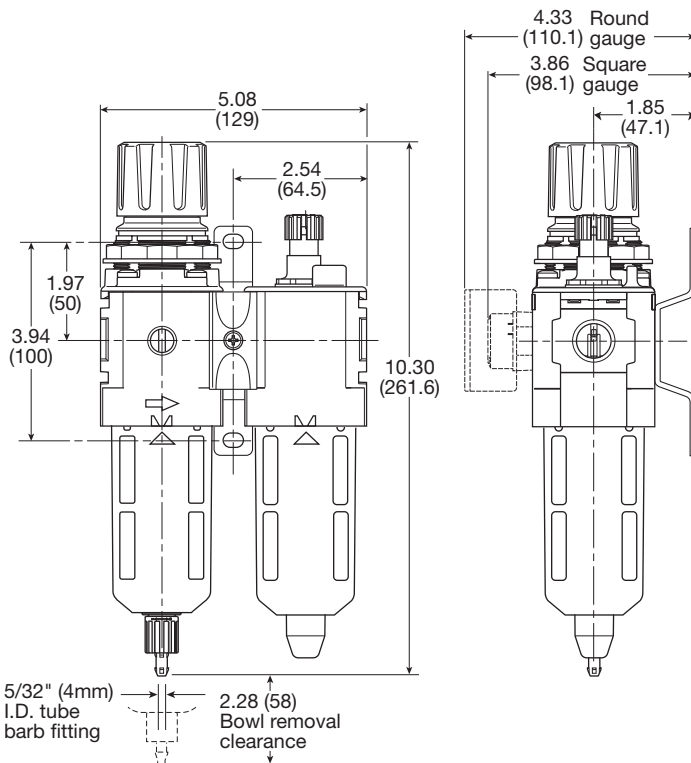

Manual Drain

Inches (mm)

 = "Most Popular"

Note: For Kits and Repair Parts, see individual pages for Filters, Regulators, and Lubricators.

 WARNING
<p>Product rupture can cause serious injury. Do not connect regulator to bottled gas. Do not exceed maximum primary pressure rating.</p>

CAUTION:

REGULATOR PRESSURE ADJUSTMENT – The working range of knob adjustment is designed to permit outlet pressures within their full range. Pressure adjustment beyond this range is also possible because the knob is not a limiting device. This is a common characteristic of most industrial regulators, and limiting devices may be obtained only by special design.

For best performance, regulated pressure should always be set by increasing the pressure up to the desired setting.

Ordering Information

Model Type	Port Size	Plastic Bowl / Bowl Guard Without Gauge 0 to 125 PSI (0 to 8.6 bar)	Plastic Bowl / Bowl Guard With Gauge 0 to 125 PSI (0 to 8.6 bar)
Manual Drain	1/4	D18-02-FK00B	D18-02-FKG0B
	3/8	D18-03-FK00B	D18-03-FKG0B
	1/2	D18-04-FK00B	D18-04-FKG0B
Automatic Drain	1/4	D18-02-FG00B	D18-02-FGG0B
	3/8	D18-03-FG00B	D18-03-FGG0B
	1/2	D18-04-FG00B	D18-04-FGG0B

Options - To order an option supplied with the unit model, add the appropriate coded suffix letter in the designated position of the model number.

Combination D28

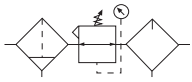

Features

- Components Integrated into Single Unit
- Modern Design and Appearance
- Light Weight, Ready-to-Mount Assembly Comes Standard with Pressure Gauge and Modular T-Bracket / Joiner Assembly
- High Flow Capacity
- Quick-Disconnect Bowl / Bowl Guard

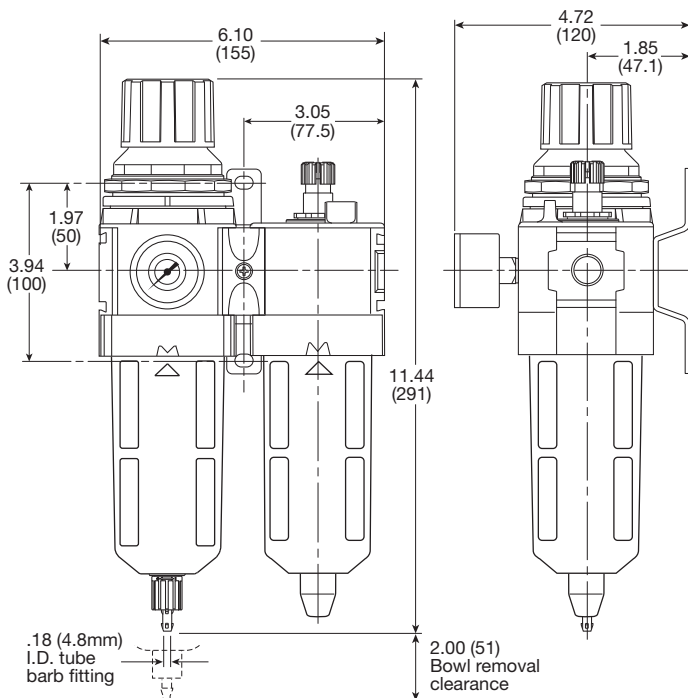

Manual Drain

Inches (mm)

Specifications

Flow Capacity*	3/8	110 SCFM (52 dm ³ /s, ANR)
	1/2	110 SCFM (52 dm ³ /s, ANR)
	3/4	150 SCFM (71 dm ³ /s, ANR)
Maximum Supply Pressure	Plastic Bowl	150 PSIG (10.3 bar)
	Metal Bowl	250 PSIG (17.2 bar)
Operating Temperature	Plastic Bowl	-13° to 125°F (-25° to 52°C)
	Metal Bowl	-13° to 150°F (-25° to 65.5°C)
Port Size	NPT/BSPP-G	3/8, 1/2, 3/4
Standard Filtration	5 Micron	
Weight	4.65 lb. (2.1 kg)	

* Inlet pressure 145 PSIG (10 bar), Secondary pressure 91.3 PSIG (6.3 bar), 14.5 PSIG (1 bar) pressure drop.

“F” Series Filters, Type “A” 5 micron elements: All Wilkerson Type “A” 5 micron elements **meet or exceed ISO Class 3** for maximum particle size and concentration of solid contaminants.

Materials of Construction

Body	Aluminum	
Body Cap	ABS	
Bonnet / Knob	Nylon / Acetal	
Bowls	Plastic Bowl	Polycarbonate
	Metal Bowl	Aluminum
Diaphragm Assembly	Nitrile / Zinc	
Element Retainer / Baffle and Deflector	Acetal	
	Polypropylene	
Filter Element	Polyethylene	
Seals	Plastic Bowl	Nitrile
	Metal Bowl	Nitrile
Sight Dome	Polycarbonate	
Sight Gauge	Metal Bowl	Polyamide (Nylon)
Springs	Main Regulating Valve	Steel
		Stainless Steel
Suggested Lubricant	Airline Oil F442001	
Valve Assembly	Brass / Nitrile / Acetal	

 = "Most Popular"

Note: For Kits and Repair Parts, see individual pages for Filters, Regulators, and Lubricators.

 WARNING
<p>Product rupture can cause serious injury. Do not connect regulator to bottled gas. Do not exceed maximum primary pressure rating.</p>

CAUTION:

REGULATOR PRESSURE ADJUSTMENT – The working range of knob adjustment is designed to permit outlet pressures within their full range. Pressure adjustment beyond this range is also possible because the knob is not a limiting device. This is a common characteristic of most industrial regulators, and limiting devices may be obtained only by special design.

For best performance, regulated pressure should always be set by increasing the pressure up to the desired setting.

Ordering Information

Model Type	Port Size	Plastic Bowl / Bowl Guard With Gauge 0 to 125 PSI (0 to 8.6 bar)	Metal Bowl / Sight Gauge With Gauge 0 to 125 PSI (0 to 8.6 bar)	Plastic Bowl / Bowl Guard With Gauge & End Blocks 0 to 125 PSI(0 to 8.6 bar)
Manual Drain	3/8	D28-03-FKG0B	D28-03-FLG0B	D28-03-FKBGB
	1/2	D28-04-FKG0B	D28-04-FLG0B	D28-04-FKBGB
	3/4	D28-06-FKG0B	D28-06-FLG0B	D28-06-FKBGB
Automatic Drain	3/8	D28-03-FGG0B	D28-03-FHG0B	D28-03-FGBGB
	1/2	D28-04-FGG0B	D28-04-FHG0B	D28-04-FGBGB
	3/4	D28-06-FGG0B	D28-06-FHG0B	D28-06-FGBGB

Options - To order an option supplied with the unit model, add the appropriate coded suffix letter in the designated position of the model number.

Combination D90

= "Most Popular"

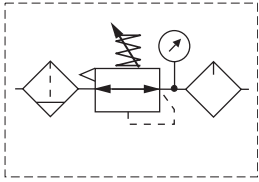

Options

D90 - 0 6 - A H G M

Unit function	Thread type*	Port size	Regulator function / pressure	Bowl / drain type	Option	Option
Filter / Regulator + Lubricator D90	NPT 0 BSPP C	3/4 6 1 8	A Relieving / 0-174 PSI	H Metal bowl with sight gauge / auto drain L Metal bowl with sight gauge / manual drain	G Gauge	M Mounting bracket

*Note: For 1-1/2" ported unit, please order P3YKA*BCP port block kit separately.
Bold items are most common.

Filter / Regulator + Lubricator Combinations

5 micron element, 12 bar (174 psig) regulator + gauge and wall mounting bracket

Ordering information

Port size	Flow [†] scfm	Weight kg (lb)	Combined manual / semi-auto drain part number [†]	Auto drain part number [†]
3/4"	315	2.8 (6.2)	D90-06-ALGM	D90-06-AHGM
1"	340	2.8 (6.2)	D90-08-ALGM	D90-08-AHGM

[†] Standard part numbers shown in bold. For other models refer to Options chart below.
[‡] Flow with 10 bar (145 psig) inlet pressure, 6.3 bar (91.4 psig) set pressure and 1 bar (14.5 psig) pressure drop.

Note: For Kits and Repair Parts, see individual pages for Filters, Regulators, and Lubricators.

 WARNING
<p>Product rupture can cause serious injury. Do not connect regulator to bottled gas. Do not exceed maximum primary pressure rating.</p>

CAUTION:

REGULATOR PRESSURE ADJUSTMENT – The working range of knob adjustment is designed to permit outlet pressures within their full range. Pressure adjustment beyond this range is also possible because the knob is not a limiting device. This is a common characteristic of most industrial regulators, and limiting devices may be obtained only by special design.

For best performance, regulated pressure should always be set by increasing the pressure up to the desired setting.

Dimensions mm (inches)

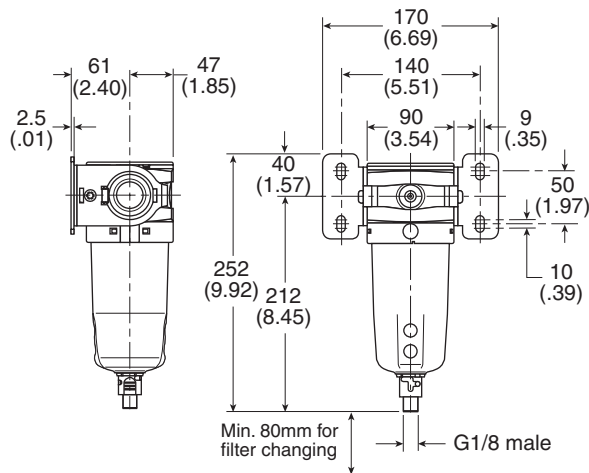
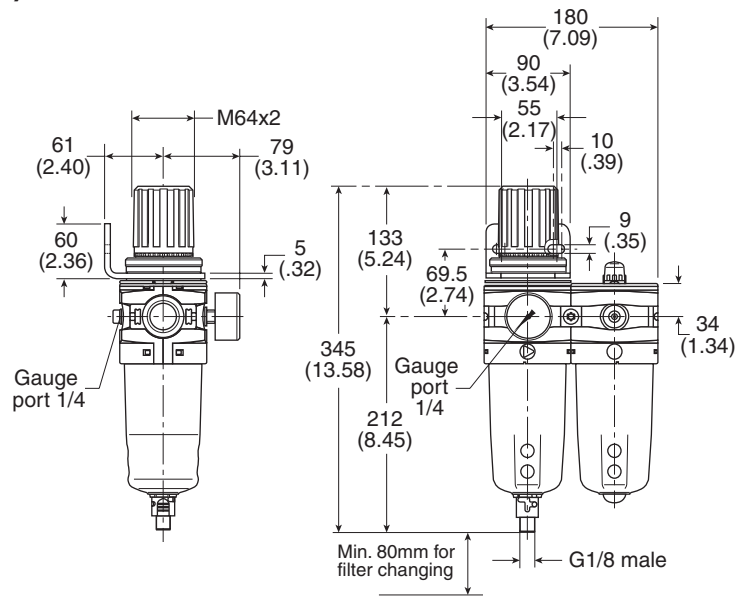

Notes

Bold items are most common.

Combination Numbering System

 = "Most Popular"

Unit Function

C

Unit Function
C F-R-L Trio

Family

1

8

Family
08 Miniature
18 Compact
28 Standard

Thread Type

0

Thread Type
0 NPT
C BSPP ²

Pipe Size

3

Code	Pipe Size	Series		
2	1/4"	X	X	X
3	3/8"		X	X
4	1/2"		X	X
6	3/4"			X

F-R-L Trio

F

Bowls / Drains

K

Drains	Bowls	
	Plastic w / Guard Nitrile Standard	Metal w/Sight Gauge ³ Nitrile Standard
Automatic Drain (18 & 28 Series Only)	G	H
Manual Drain	K	L
Piston Drain (08 Series Only)	R	S

Options

G

Options
0 None
C Tamper Resistant Regulator Kit ¹
D Force Fill Adapter
G Pressure Gauge (08 Square) (18 & 28 Round)
L Differential Pressure Indicator (18 & 28 Only)
N Lubricator with No Drain
P Metal Panel Nut
R Electronic Differential Pressure Indicator (18 & 28 Series Only)
S Square Gauge (18 Series only)

Options

0

Options
0 None
C Tamper Resistant Regulator Kit ¹
D Force Fill Adapter
G Pressure Gauge (08 Square) (18 & 28 Round)
L Differential Pressure Indicator (18 & 28 Only)
N Lubricator with No Drain
P Metal Panel Nut
R Electronic Differential Pressure Indicator (18 & 28 Series Only)
S Square Gauge (18 Series only)

Level

B

Code	Series
B	08
B	18
B	28

Diaphragm Function	Fluorocarbon (18 & 28 Series Only)	Spring Range			
		0 to 30 PSIG (0 to 2.1 bar)	0 to 60 PSIG (0 to 4.1 bar)	0 to 125 PSIG (0 to 8.6 bar)	0 to 250 PSIG ⁴ (0 to 17.2 bar)
Relieving	No	C	D	F	G
	Yes	J	K	L	M
Non-relieving	No	P	W	R	S
	Yes	V	X	Y	Z

Wilkerson combination models are offered with the T-bracket(s) as standard.

¹ Tamper resistant kit not installed. Kit shipped loose in carton.
² ISO, R228 (G Series).
³ 08 series has all metal bowl (no sight gauge).
⁴ 08 series operating range 0 to 232 PSIG (1 to 16 bar).

"F" Series Filters, Type "A" 5 micron elements: All Wilkerson Type "A" 5 micron elements **meet or exceed** ISO Class 3 for maximum particle size and concentration of solid contaminants.

NOTE: All classes above refer to International Standards Organization (ISO) standard 8573-1, pertaining to maximum particle size and concentration of solid contaminants, and maximum oil content.

NOTE: When selecting from the options columns, please enter letters in alphabetical order for positions 7, 8, 9. For example:

C 1 8 - 0 3 - F K G 0 B

*Note: For 1-1/2" ported unit, please order P3YKA*BCP port block kit separately.

Combination C08

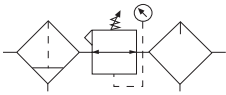

Features

- Components Integrated into Single Unit
- Modern Design and Appearance
- Light Weight, Ready-to-Mount Assembly Comes Standard with Flush-Mount Pressure Gauge and Modular T-bracket / Joiner Assembly
- High Flow Capacity
- Quick-Disconnect Bowl / Bowl Guard

Specifications

Flow Capacity*	1/4	27 SCFM (13 dm ³ /s, ANR)
Gauge Port** (2)	NPT	1/8
Maximum Supply Pressure	Plastic Bowl	150 PSIG (10.3 bar)
	Metal Bowl	250 PSIG (17.2 bar)
Operating Temperature	Plastic Bowl	14° to 125°F (-10° to 52°C)
	Metal Bowl	14° to 150°F (-10° to 65.5°C)
Port Size	NPT / BSPP-G	1/4
Standard Filtration		5 Micron
Weight		1.96 lb. (0.9 kg)

* Inlet pressure 145 PSIG (10 bar), Secondary pressure 91.3 PSIG (6.3 bar), 14.5 PSIG (1 bar) pressure drop.

** Non-gauge option only.

"F" Series Filters, Type "A" 5 micron elements: All Wilkerson Type "A" 5 micron elements **meet or exceed ISO Class 3** for maximum particle size and concentration of solid contaminants.

Materials of Construction

Body	Aluminum	
Bonnet	PBT	
Bowl	Plastic Bowl	Polycarbonate
	Metal Bowl	Aluminum
Bowl Guard	Nylon	
Diaphragm Assembly	Brass / Nitrile	
Filter Element	Polyethylene	
Knob	Acetal	
Seals	Plastic Bowl	Nitrile
	Metal Bowl	Nitrile
Sight Dome	Polycarbonate	
Springs	Steel	
Suggested Lubricant	Airline Oil F442001	
Valve	Brass / Nitrile	

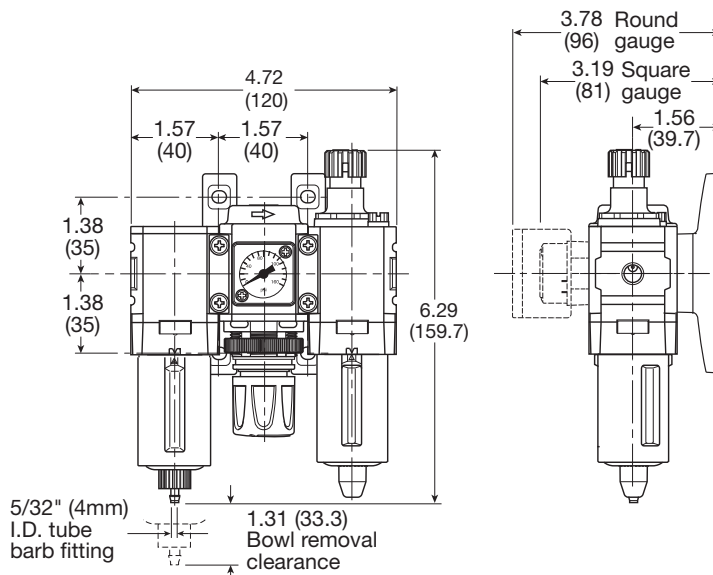

Inches (mm)

Manual Drain

 = "Most Popular"

Note: For Kits and Repair Parts, see individual pages for Filters, Regulators, and Lubricators.

 WARNING
<p>Product rupture can cause serious injury. Do not connect regulator to bottled gas. Do not exceed maximum primary pressure rating.</p>

CAUTION:

REGULATOR PRESSURE ADJUSTMENT – The working range of knob adjustment is designed to permit outlet pressures within their full range. Pressure adjustment beyond this range is also possible because the knob is not a limiting device. This is a common characteristic of most industrial regulators, and limiting devices may be obtained only by special design.

For best performance, regulated pressure should always be set by increasing the pressure up to the desired setting.

Ordering Information

Model Type	Port Size	Plastic Bowl / Bowl Guard / Without Gauge 0 to 125 PSI (0 to 8.6 bar)	Plastic Bowl / Bowl Guard / With Gauge 0 to 125 PSI (0 to 8.6 bar)	Metal Bowl / Without Gauge 0 to 125 PSI (0 to 8.6 bar)	Metal Bowl / With Gauge 0 to 125 PSI (0 to 8.6 bar)
Manual Drain	1/4	C08-02-FK00B	C08-02-FKG0B	C08-02-FL00B	C08-02-FLG0B

Options - To order an option supplied with the unit model, add the appropriate coded suffix letter in the designated position of the model number.

Combination C18

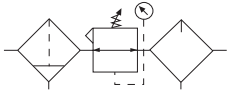

Features

- Components Integrated into Single Unit
- Modern Design and Appearance
- Light Weight, Ready-to-Mount Assembly Comes Standard with Pressure Gauge and Modular T-Bracket / Joiner Assembly
- High Flow Capacity
- Quick-Disconnect Bowl / Bowl Guard

Specifications

Flow Capacity*	1/4	42 SCFM (20 dm ³ /s, ANR)
	3/8	68 SCFM (32 dm ³ /s, ANR)
	1/2	85 SCFM (40 dm ³ /s, ANR)
Gauge Port (2)	NPT / BSPP-G 1/4	
Maximum Supply Pressure	Plastic Bowl	150 PSIG (10.3 bar)
	Metal Bowl	250 PSIG (17.2 bar)
Operating Temperature	Plastic Bowl	-13° to 125°F (-25° to 52°C)
	Metal Bowl	-13° to 150°F (-25° to 65.5°C)
Port Size	NPT / BSPP-G 1/4, 3/8, 1/2	
Standard Filtration	5 Micron	
Weight	4.04 lb. (1.83 kg)	

* Inlet pressure 145 PSIG (10 bar), Secondary pressure 91.3 PSIG (6.3 bar), 14.5 PSIG (1 bar) pressure drop.

"F" Series Filters, Type "A" 5 micron elements: All Wilkerson Type "A" 5 micron elements **meet or exceed ISO Class 3** for maximum particle size and concentration of solid contaminants.

Materials of Construction

Body	Aluminum	
Bonnet / Knob	Nylon / Acetal	
Bowls	Plastic Bowl	Polycarbonate
	Metal Bowl	Aluminum
Diaphragm Assembly	Nitrile / Zinc	
Filter Element	Polyethylene	
Seals	Plastic Bowl	Nitrile
	Metal Bowl	Nitrile
Sight Dome	Polycarbonate	
Sight Gauge	Metal Bowl	Polyamide (Nylon)
Springs	Main Regulating Valve	Steel Stainless Steel
Suggested Lubricant	Airline Oil F442001	
Valve	Brass / Nitrile	

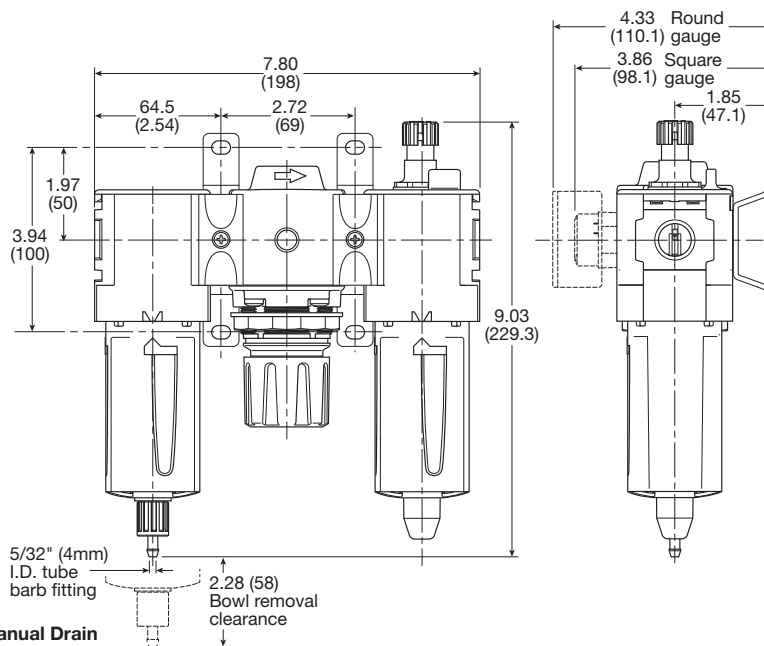

Inches (mm)

Manual Drain

 = "Most Popular"

Note: For Kits and Repair Parts, see individual pages for Filters, Regulators, and Lubricators.

 WARNING
<p>Product rupture can cause serious injury. Do not connect regulator to bottled gas. Do not exceed maximum primary pressure rating.</p>

CAUTION:

REGULATOR PRESSURE ADJUSTMENT – The working range of knob adjustment is designed to permit outlet pressures within their full range. Pressure adjustment beyond this range is also possible because the knob is not a limiting device. This is a common characteristic of most industrial regulators, and limiting devices may be obtained only by special design.

For best performance, regulated pressure should always be set by increasing the pressure up to the desired setting.

Ordering Information

Model Type	Port Size	Plastic Bowl / Bowl Guard / With Gauge 0 to 125 PSI (0 to 8.6 bar)	Metal Bowl / Sight Gauge / With Gauge 0 to 125 PSI (0 to 8.6 bar)	Plastic Bowl / Bowl Guard / With Gauge & End Blocks 0 to 125 PSI (0 to 8.6 bar)
Manual Drain	1/4	C18-02-FKG0B	C18-02-FLG0B	C18-02-FKBGB
	3/8	C18-03-FKG0B	C18-03-FLG0B	C18-03-FKBGB
	1/2	C18-04-FKG0B	C18-04-FLG0B	C18-04-FKBGB
Automatic Drain	1/4	C18-02-FGG0B	C18-02-FHG0B	C18-02-FGBGB
	3/8	C18-03-FGG0B	C18-03-FHG0B	C18-03-FGBGB
	1/2	C18-04-FGG0B	C18-04-FHG0B	C18-04-FGBGB

Options - To order an option supplied with the unit model, add the appropriate coded suffix letter in the designated position of the model number.

Combination C28

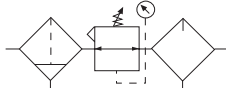

Features

- Components Integrated into Single Unit
- Modern Design and Appearance
- Light Weight, Ready-to-Mount Assembly Comes Standard with Pressure Gauge and Modular T-Bracket / Joiner Assembly
- High Flow Capacity
- Quick-Disconnect Bowl / Bowl Guard

Specifications

Flow Capacity*	3/8	90 SCFM (43 dm ³ /s, ANR)
	1/2	90 SCFM (43 dm ³ /s, ANR)
	3/4	110 SCFM (52 dm ³ /s, ANR)
Gauge Port (2)	NPT / BSPP-G	1/4
Maximum Supply Pressure	Plastic Bowl	150 PSIG (10.3 bar)
	Metal Bowl	250 PSIG (17.2 bar)
Operating Temperature	Plastic Bowl	-13° to 125°F (-25° to 52°C)
	Metal Bowl	-13° to 150°F (-25° to 65.5°C)
Port Size	NPT / BSPP-G	3/8, 1/2, 3/4
Standard Filtration	5 micron	
Weight	5.90 lb. (2.6 kg)	

* Inlet pressure 145 PSIG (10 bar), Secondary pressure 91.3 PSIG (6.3 bar), 14.5 PSIG (1 bar) pressure drop.

"F" Series Filters, Type "A" 5 micron elements: All Wilkerson Type "A" 5 micron elements **meet or exceed ISO Class 3** for maximum particle size and concentration of solid contaminants.

Materials of Construction

Body	Aluminum	
Bonnet / Knob	Nylon / Acetal	
Bowls	Plastic Bowl	Polycarbonate
	Metal Bowl	Aluminum
Diaphragm Assembly	Nitrile / Zinc	
Filter Element	Polyethylene	
Seals	Plastic Bowl	Nitrile
	Metal Bowl	Nitrile
Sight Dome	Polycarbonate	
Sight Gauge	Metal Bowl	Polyamide (Nylon)
Springs	Main Regulating Valve	Steel
		Stainless Steel
Suggested Lubricant	Airline Oil F442001	
Valve	Brass / Nitrile / Acetal	

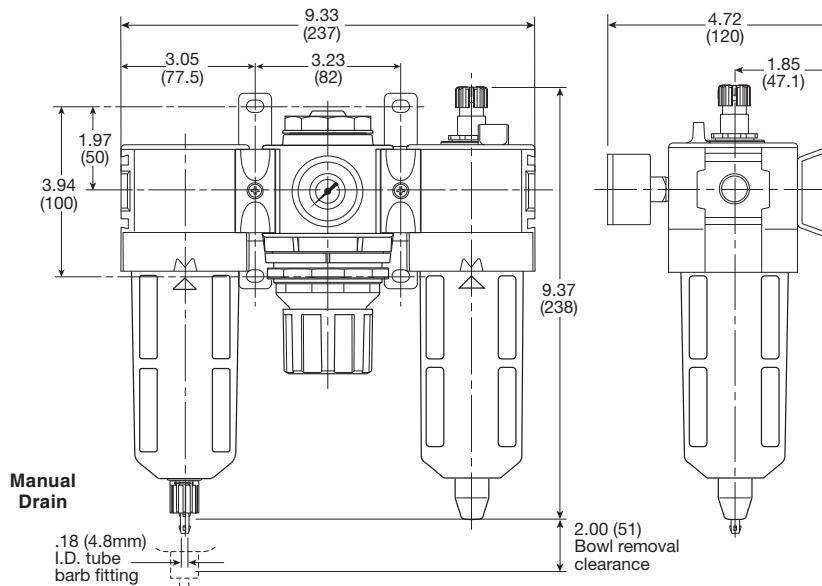

Inches (mm)

 = "Most Popular"

Note: For Kits and Repair Parts, see individual pages for Filters, Regulators, and Lubricators.

 WARNING
<p>Product rupture can cause serious injury. Do not connect regulator to bottled gas. Do not exceed maximum primary pressure rating.</p>

CAUTION:

REGULATOR PRESSURE ADJUSTMENT – The working range of knob adjustment is designed to permit outlet pressures within their full range. Pressure adjustment beyond this range is also possible because the knob is not a limiting device. This is a common characteristic of most industrial regulators, and limiting devices may be obtained only by special design.

For best performance, regulated pressure should always be set by increasing the pressure up to the desired setting.

Ordering Information

Model Type	Port Size	Plastic Bowl / Bowl Guard / With Gauge 0 to 125 PSI (0 to 8.6 bar)	Metal Bowl / Sight Gauge / With Gauge 0 to 125 PSI (0 to 8.6 bar)	Plastic Bowl / Bowl Guard / With Gauge & End Blocks 0 to 125 PSI (0 to 8.6 bar)
Manual Drain	3/8	C28-03-FKG0B	C28-03-FLG0B	C28-03-FKBGB
	1/2	C28-04-FKG0B	C28-04-FLG0B	C28-04-FKBGB
	3/4	C28-06-FKG0B	C28-06-FLG0B	C28-06-FKBGB
Automatic Drain	3/8	C28-03-FGG0B	C28-03-FHG0B	C28-03-FGBGB
	1/2	C28-04-FGG0B	C28-04-FHG0B	C28-04-FGBGB
	3/4	C28-06-FGG0B	C28-06-FHG0B	C28-06-FGBGB

Options - To order an option supplied with the unit model, add the appropriate coded suffix letter in the designated position of the model number.

Combination C90

= "Most Popular"

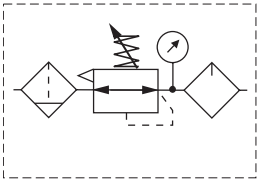

Options

C90	-	0	-	6	-	A	-	H	-	G	-	M
Unit function		Thread type*		Port size		Regulator function / pressure		Bowl / drain type		Option		Option
Filter + Regulator + Lubricator C90		NPT 0 BSPP C		3/4 6 1 8		A Relieving / 0-174 PSI		H Metal bowl with sight gauge / auto drain L Metal bowl with sight gauge / manual drain		G Gauge		M Mounting bracket

*Note: For 1-1/2" ported unit, please order P3YKA*BCP port block kit separately.
Bold items are most common.

Filter + Regulator + Lubricator Combinations 5 micron element, 12 bar (174 psig) regulator + gauge and wall mounting bracket

Ordering information

Port size	Flow† scfm	Weight kg (lb)	Combined manual / semi-auto drain part number†	Auto drain part number†
3/4"	170	3.3 (7.3)	C90-06-ALGM	C90-06-AHGM
1"	170	3.3 (7.3)	C90-08-ALGM	C90-08-AHGM

† Standard part numbers shown in bold. For other models refer to Options chart below.
 ‡ Flow with 10 bar (145 psig) inlet pressure, 6.3 bar (91.4 psig) set pressure and 1 bar (14.5 psig) pressure drop.

Note: For Kits and Repair Parts, see individual pages for Filters, Regulators, and Lubricators.

 WARNING
<p>Product rupture can cause serious injury. Do not connect regulator to bottled gas. Do not exceed maximum primary pressure rating.</p>

CAUTION:

REGULATOR PRESSURE ADJUSTMENT – The working range of knob adjustment is designed to permit outlet pressures within their full range. Pressure adjustment beyond this range is also possible because the knob is not a limiting device. This is a common characteristic of most industrial regulators, and limiting devices may be obtained only by special design.

For best performance, regulated pressure should always be set by increasing the pressure up to the desired setting.

Dimensions mm (inches)

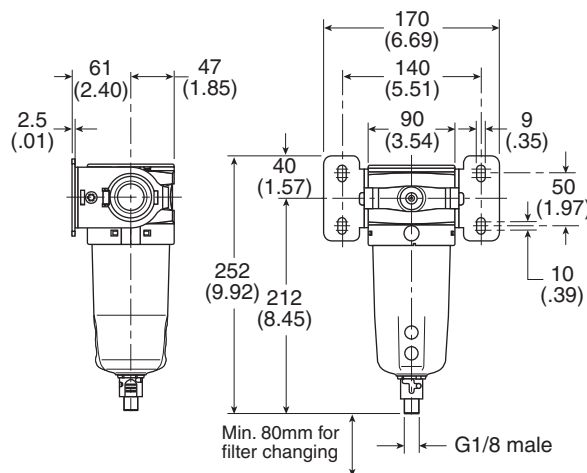
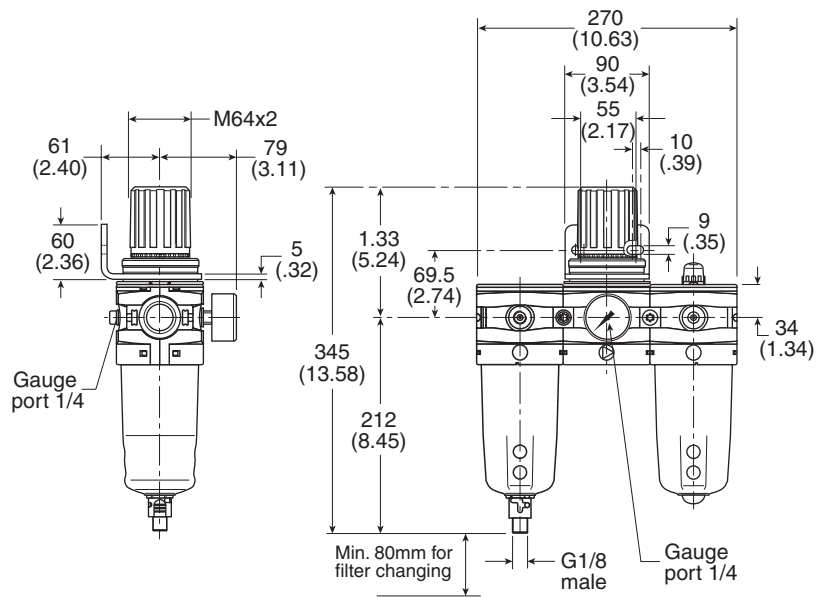

Notes

Slow-Start / Quick Dump Valve Numbering System

 = "Most Popular"

Slow-Start / Quick Dump Valve

The Slow-Start / Quick Dump Valve is designed as a three-way Quick Dump Valve with a built-in Slow-Start capability. This Slow-Start capability allows control of downstream pressure buildup at start-up of a compressed air system. The combination of Slow-Start

and Quick Dump reduces the number of pneumatic components and the unique volume-independent design allows any number of additions to the pneumatic circuit without readjusting the Slow-Start function.

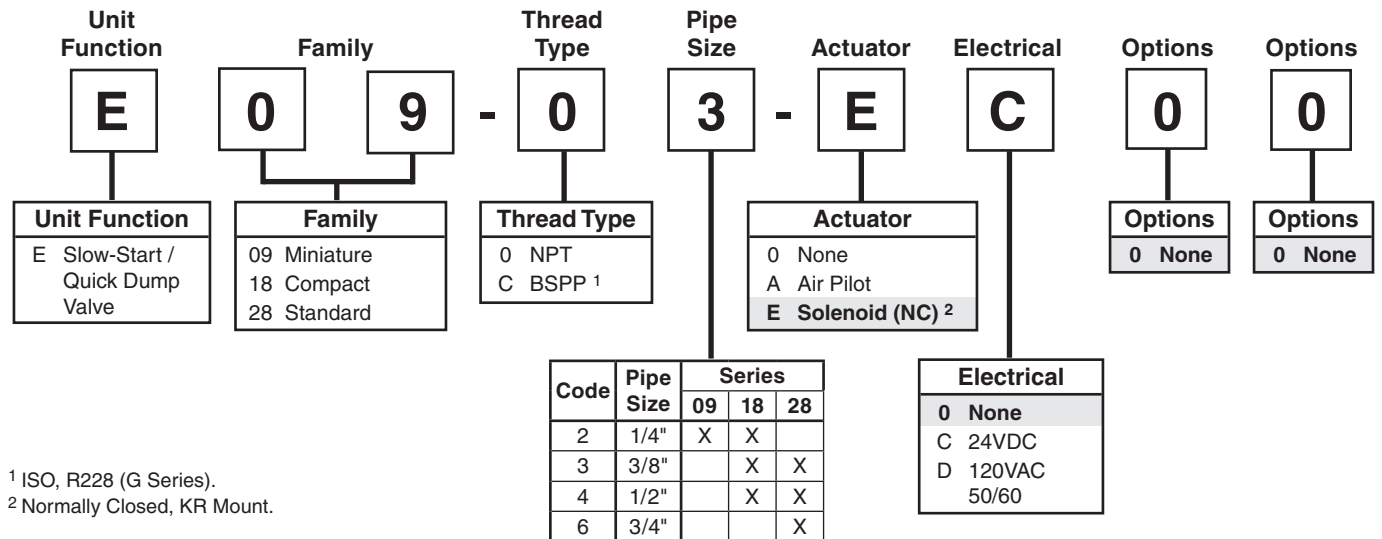

Soft Start Valve Numbering System

Soft Start Valve

The Soft Start Valves, provide for the safe introduction of pressure to machines or systems. Soft Start Valves, allow the pressure to gradually build to the set point before fully opening to deliver full flow at line pressure. The controlled introduction of pressure can be an

important safety factor and prevent damage to tooling when air pressure is introduced at machine or system start up.

Note: Soft Start Valves must be installed downstream of a 3/2 valve with exhaust capability

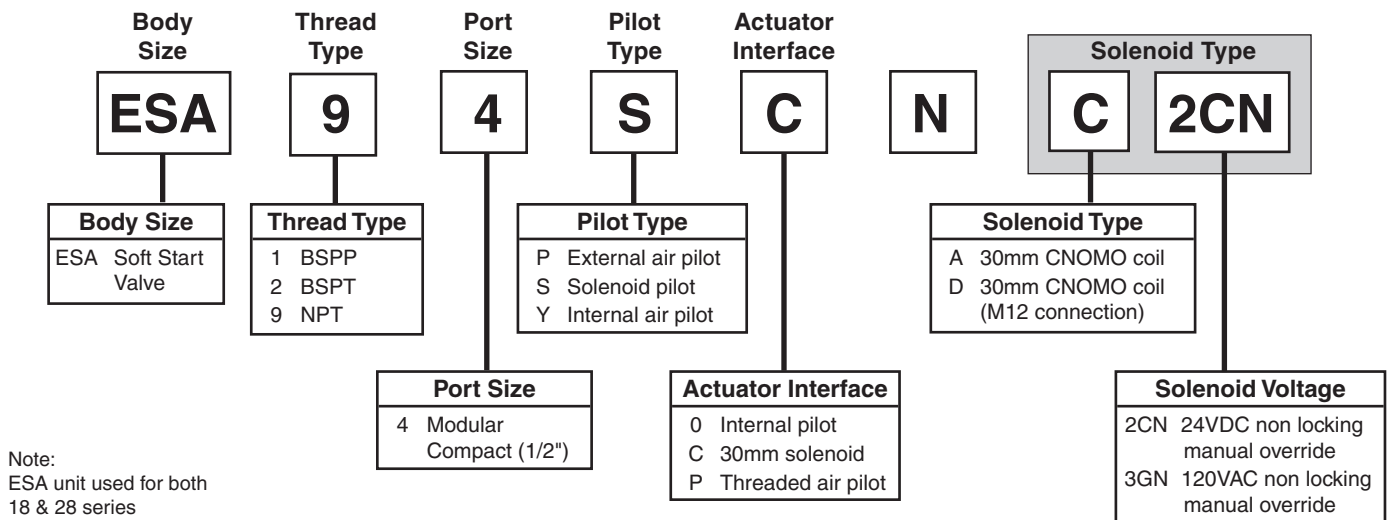

Slow-Start / Quick Dump Valve E18 / E28

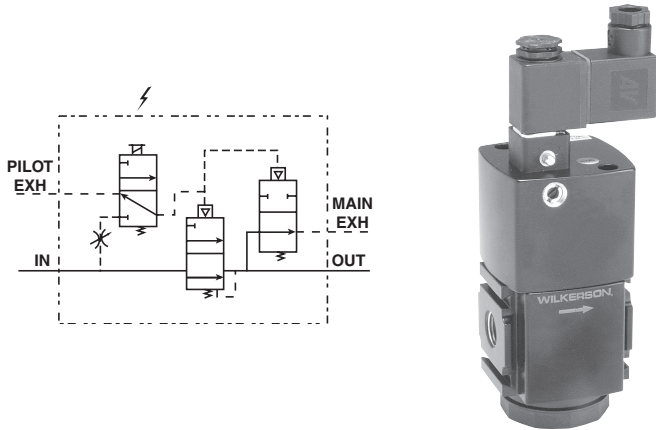

Specifications

Flow Capacity*	E18	1/4	95 SCFM (44.8 dm ³ /s)
		3/8	101 SCFM (47.7 dm ³ /s)
		1/2	113 SCFM (53.3 dm ³ /s)
	E28	3/8	196 SCFM (92.5 dm ³ /s)
		1/2	210 SCFM (99.1 dm ³ /s)
		3/4	230 SCFM (108.5 dm ³ /s)
Exhaust Ports	NPT / BSPP-G	E18	3/8
Right Side and Rear		E28	3/8
Maximum Supply Pressure	150 PSIG (10.3 bar)		
Minimum Pressure	30 PSIG (2.1 bar)		
Operating Temperature	32° to 150°F (0° to 65.5°C)		
Port Size	NPT / BSPP-G	E18	1/4, 3/8, 1/2
		E28	3/8, 1/2, 3/4
Weight	E18	2.23 lb. (1.01 kg)	
	E28	2.50 lb. (1.14 kg)	

* Inlet pressure 150 PSIG (10.3 bar). Pressure drop 5 PSID (0.3 bar).

Features

- Modular Design
- True Volume Independence
- High Flow Capacity
- Choice of Two Exhaust Port Locations

Materials of Construction

Body	Aluminum
Bottom Plug	33% Glass-Filled Nylon
Seals	Nitrile
Springs	Music Wire / Stainless Steel
Valve Assembly	Brass / Nitrile

Replacement Kits

Actuating Valve	
KR Mount, 24VDC	VRP-95-776
KR Mount, 120VAC	VRP-95-777
CNOMO, 24VDC	VRP-95-778
CNOMO, 120VAC	VRP-95-779
Muffler	VRP-95-780
Valve / Spring Kit	VRP-95-781
Repair Kit (Includes Valve / Spring)	VRP-95-782
Body Cap Kit	
E18	VRP-95-784
E28	VRP-95-785
KR to CNOMO Adapter Block	VRP-95-712
C-Bracket -	
E18	GPA-97-086
E28	GPA-97-087

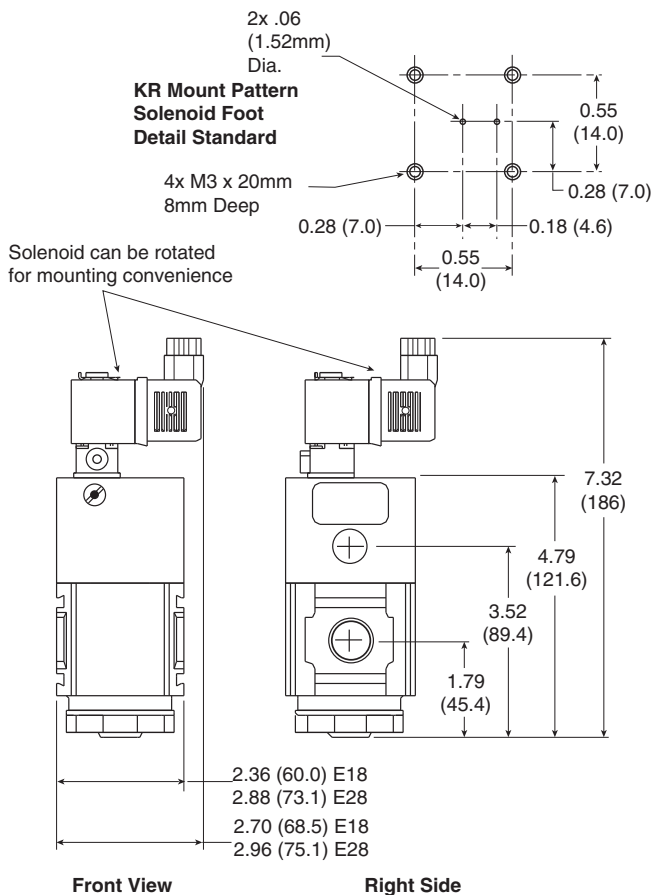

Inches (mm)

 = "Most Popular"

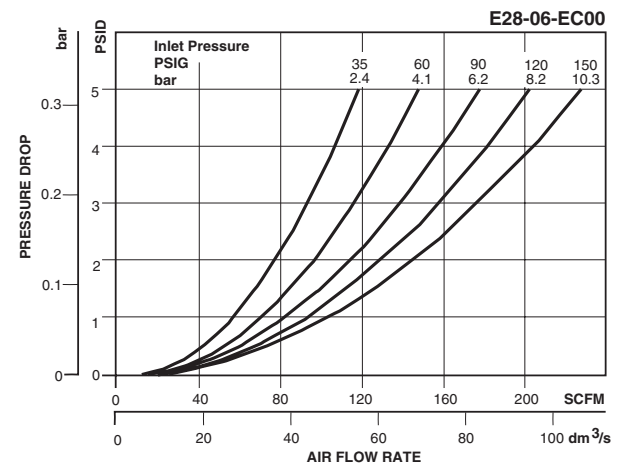
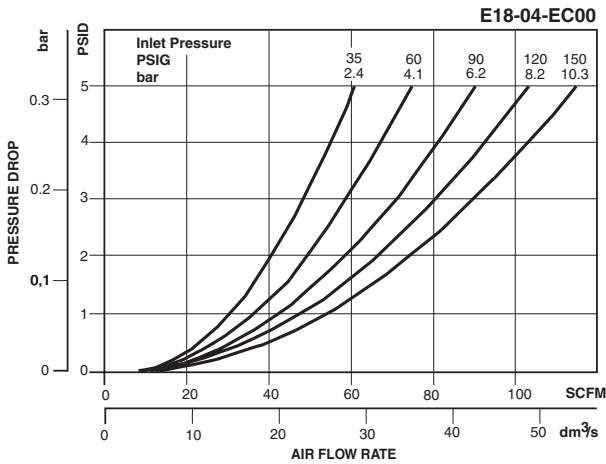
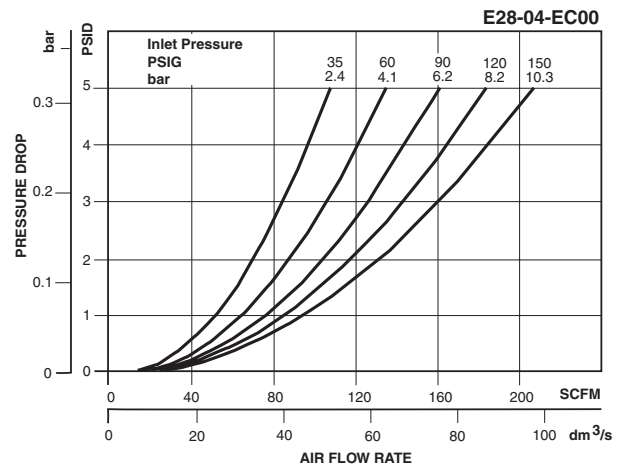
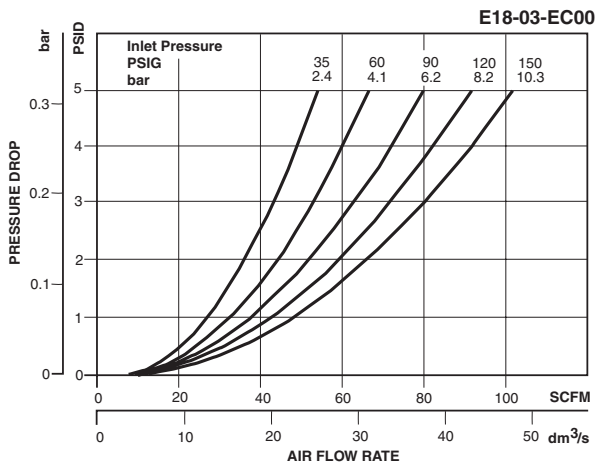
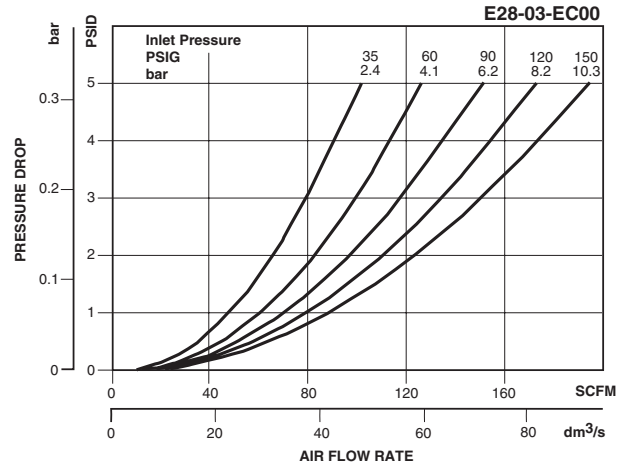
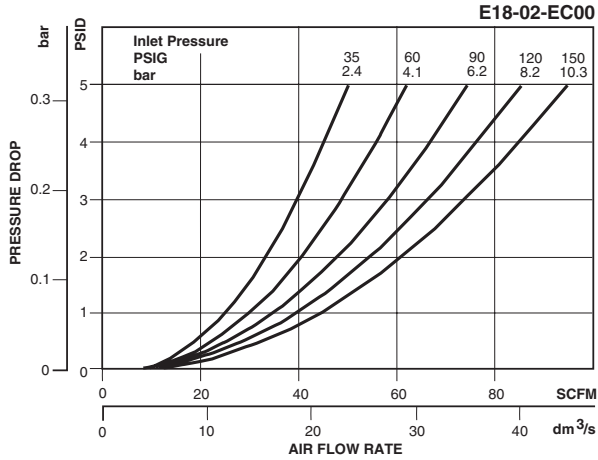

Ordering Information

Model Type	Port Size	24V / DC N.C.	120V / 60 Hz N.C.
E18	1/4	E18-02-EC00	E18-02-ED00
	3/8	E18-03-EC00	E18-03-ED00
	1/2	E18-04-EC00	E18-04-ED00
E28	3/8	E28-03-EC00	E28-03-ED00
	1/2	E28-04-EC00	E28-04-ED00
	3/4	E28-06-EC00	E28-06-ED00

Options - To order an option supplied with the unit model, add the appropriate coded suffix letter in the designated position of the model number.

Soft Start Valves ESA

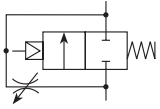

Features

- Modular design with 1/2" integral ports (NPT & BSPP)
- The 2-way, 2-position function provides for the safe introduction of pressure
- Adjustable slow start
- Solenoid or air pilot options
- High flow

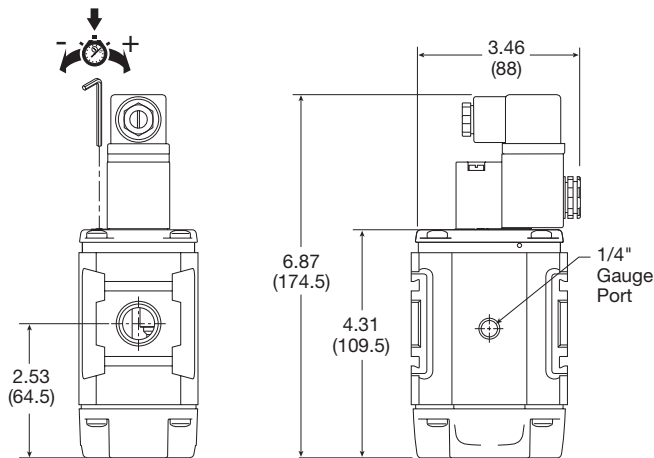

Soft Start Function:

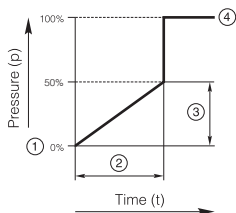

- ① Start signal
- ② Switching time delay
- ③ Gradual pressure build up
- ④ Operating pressure $p^2 (=p^1)$

Specifications

Flow Capacity*	1/2	101 SCFM (47.7 dm ³ /s)
Maximum Supply Pressure		
Solenoid operated		150 PSIG (10.3 bar)
Air pilot operated		250 PSIG (7 bar)
Minimum Pressure		44 PSIG (3 bar)
Temperature Range (max)†		
Solenoid operated		14° to 122°F (-10° to 50°C)
Air pilot operated		-4° to 176°F (-20° to 80°C)
Fluid		Compressed air
Ports		
Air pilot		1/8
Gauge		1/4

* Inlet pressure 91.3 PSIG (6.3 bar), inlet pressure and 14.5 (1 bar) pressure drop.

† Air supply must be dry enough to avoid ice formation at temperatures below 35.6°F (2°C). Snap pressure: Full flow when downstream pressure reaches 50% of the inlet pressure.

Materials of Construction

Body	Aluminum
Body cover	Polyester
Seals	Nitrile NBR

ESA 1/2" Soft Start Valve

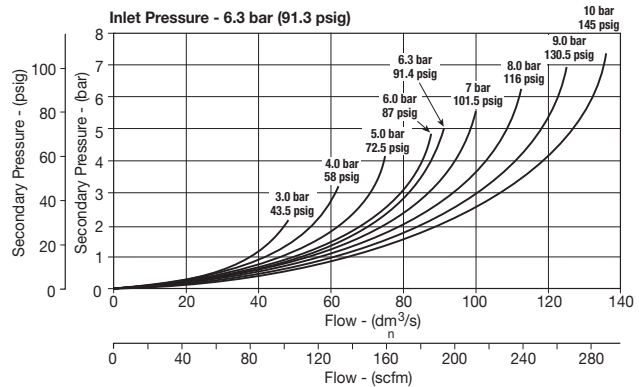

Ordering Information

Port size	Description	Weight lbs (kg)	Part number
1/2"	120VAC 30mm coil & cable plug incl.	1.5 (0.87)	ESA94SCNA3GN
1/2"	24VDC 30mm coil & cable plug	2.0 (0.90)	ESA94SCNA2CN
1/2"	Internal air pilot operated	2.0 (0.90)	ESA94Y0N
1/2"	External air pilot (1/8 threaded)	1.5 (0.87)	ESA94PPN

Safety Exhaust Valves E28 / Q28

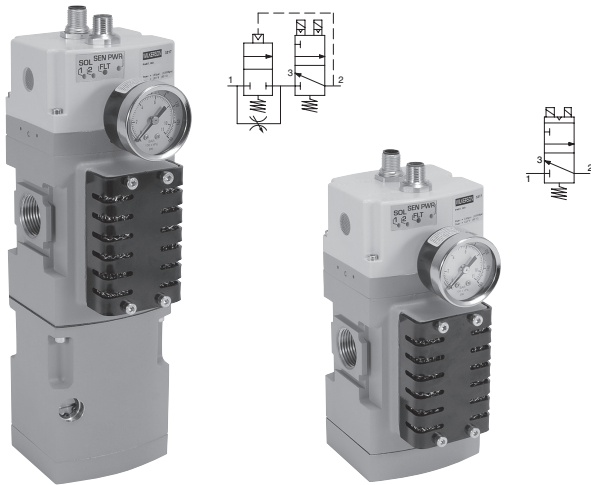

(optional soft start)

Specifications

Operating pressure:	30 to 150 PSIG (2 to 10 bar)
Minimum operating pressure:	30 PSIG (2 bar)
Ambient temperature:	40° to 120°F (4° to 50°C)
Recommended filtration:	40µ
Operating medium:	Compressed air
Ingress protection class:	IP65
B10 (mio):	10 million switching cycles
B10 d (mio):	20 million switching cycles
Allowable discordance:	150ms
Flow media:	Compresses air to ISO 8573-1 Class 7:4:4
Weight lbs (kg):	6.5 (2.9) with soft start 4.2 (1.9) without soft start

The soft start opens to full flow at approximately 60% of input pressure.

Features

- Easy electrical interface with M12 connectors to safety circuit
- External monitoring provides a cost and space saving advantage
- Solid state pressure sensors provide accurate, fast fault detection
- Quick visual LED indicators on the front of the valve
- Superior seated seal design for longer life
- Safety exhaust outlet is no-maintenance and non-clog by design
- Suitable for stand alone use or modular mounting to P32 or P33 FRL assembly
- High B10 life value
- Fast exhaust times allow for smaller machine footprint

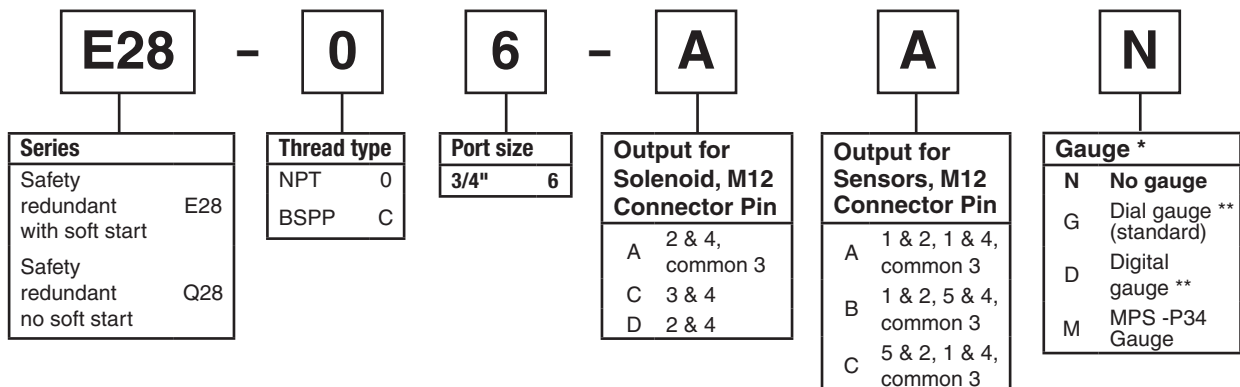
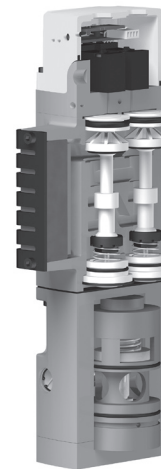

Notes:

* Safety valve supplied with 1/8" gauge port in either BSPP or NPT threads as specified for ports. Gauges shipped loose.

** Dial or digital gauge not available on BSPP version.

Note: Mounting hardware sold separately.

General Technical Data

Valve type	Externally monitored, redundant, dual poppet
Soft start	Optional
Valve function	3/2 way, normally closed
Housing material	Cast aluminum
Seals	NBR
Fasteners	Stainless steel / brass
Silencer	Steel, non clog safety design

Electrical Specifications

Operating voltage	24V DC
Electrical connection	Two M12 connectors
Switching time 1-2 (ms)	23.3
Switching time 2-3 (ms)	42.7
Duty cycle (%)	100%
Operating voltage (DC)	21.6 to 26.4
Nominal power	
per solenoid coil at 24V DC (W) +/- 10%	1.2 W
per pressure sensor at 24V DC	1.2 W

In accordance with EN ISO 13849-1 this safety valve is suitable for use up to Category 4, Plc, sil 3. Certified to cCSAus and bears the CE mark. A product Integration Guide is available to help connect your logic controller to the Parker Safety Exhaust Valve under the Product Support tab at www.parker.com/pdn/safetyvalve

Externally Monitored (with Soft Start)

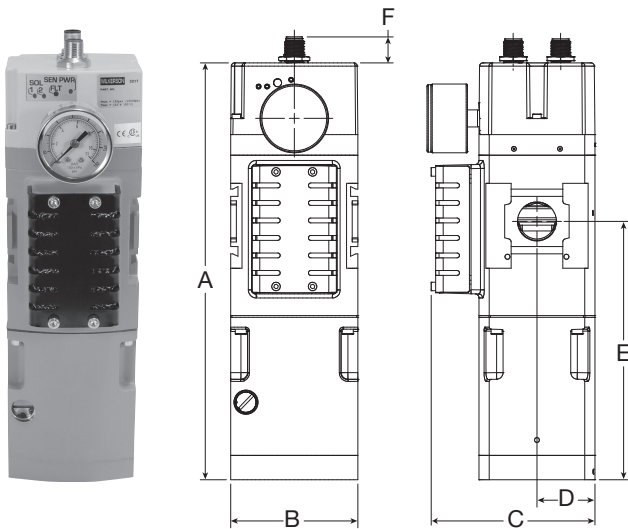

Mounting Hardware

Joiner Set		GPA-96-601
T-Bracket w / Body Connector		
T-Bracket (fits to body connector or port block)		GPA-96-602
Port Block Kits (includes one in kit)		
	1/2" NPT	GPA-96-612
	1/2" G	GPA-96-622
	3/4" NPT	GPA-96-613
	3/4" G	GPA-96-623

Solenoid M12 Pinouts

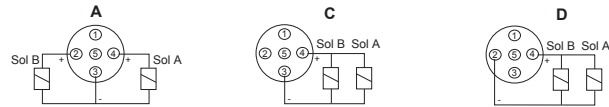

Pressure Sensor M12 Pinouts

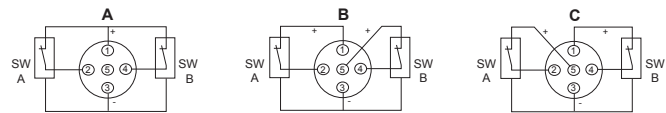

Externally Monitored (No Soft Start)

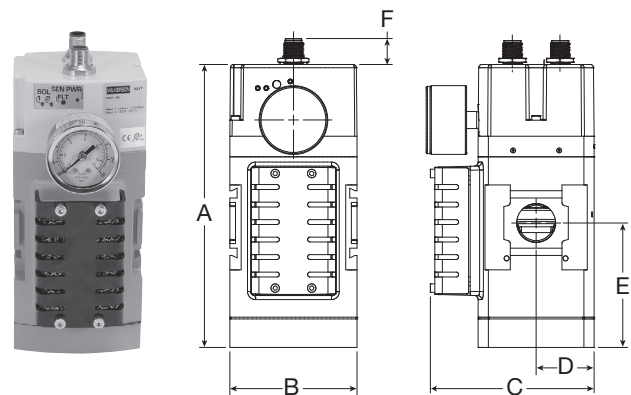

Dimensions inches (mm)

	Ports	Standard nominal flow rate		A	B	C	D	E	F
		1 → 2 L/min (SCFM)*	2 → 3 L/min (SCFM)*						
Externally Monitored with soft start	3/4"	4,100 (145)	7,500 (265)	10.31 (261.9)	3.15 (80)	4.30 (109.3)	1.44 (36.5)	6.39 (162.3)	0.64 (16.3)
Externally Monitored no soft start	3/4"	4,300 (152)	7,500 (265)	7.03 (178.7)	3.15 (80)	4.30 (109.3)	1.44 (36.5)	3.11 (79.0)	0.64 (16.3)

* Standard nominal flow rate is based on 6 bar input pressure with ΔP = 1 bar

Safety Exhaust Valve Function

When applications demand a safe environment you can count on safety valves from Wilkerson. The E28/Q28 family of safety exhaust valves are 3/2 normally closed valves designed to rapidly exhaust compressed air in the event of a fault condition and to provide monitored coverage ensuring safe function. The E28/Q28 is available in two distinct styles, internally* or externally monitored. The valve is suitable for use up to Category 4, performance level e. Monitoring is achieved externally via a two channel system connected to a safety interface device. Both valves are available with an adjustable soft start and high flow exhaust to shut your equipment down faster when needed. LED's provide clear status of main solenoid operation, sensor power and fault condition for quick visual reference.

Externally Monitored Valve, Faults and Resets

The externally monitored valve has the monitoring done via a PLC or relay which offers a size and cost advantage over internally monitored valves. The integration of a safety interface into the PLC or relay will help determine the achievable category and performance level of the control system. Customers are required to provide the logic function via the safety device. The valve will lock-out to the "safe state" if asynchronous movement of the valve elements occur which will be detected by solid state pressure sensors. To achieve the proper safety rating, the safety PLC or relay must monitor the solid state pressure sensors to ensure they are not in different states for more than 150ms. If the sensors are in different states for longer than 150ms then the programming logic must shut off power to the solenoids and consider it a fault condition. If during operation the externally monitored E28/Q28 enters a fault condition the valve will shut off. A separate reset signal must be incorporated into the logic sequence to avoid automatic restart of the valve. The safety exhaust valves are not for use with clutch or brake applications and are designed for use in conjunction with a safety relay or safety PLC for safe monitoring and fault detection.

Achieving Desired Performance Level **

The category and performance level (PLr) needed for your machine is determined by a risk assessment of the machinery design and application based on EN ISO 13849-1. The Wilkerson E28/Q28 safety valve is designed for those applications requiring a PL of d or e. Please note these levels require other aspects of the system to meet these requirements. As a guide: you can achieve a Cat 4 PL e system by integrating monitoring via a programmable safety rated device. Because the E28/Q28 is a mechanical fail-safe device, the monitoring could also be done via a standard PLC and still attain as high as a PL d rating.

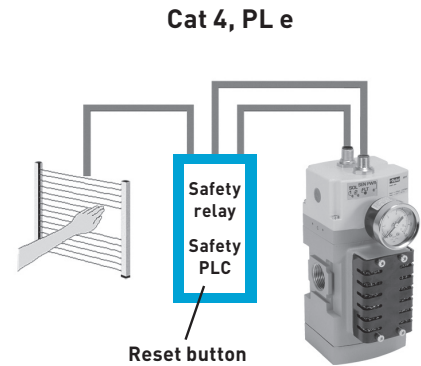
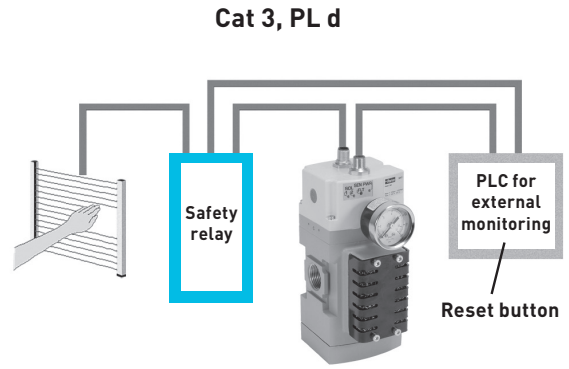

- * For information on internally monitored safety valves reference Bulletin 9EM-B4.
- ** An integration guide is available to provide further information on connecting the safety valve product to achieve the desired performance level. Please consult Wilkerson and the standard EN ISO 13849-1 for more information.

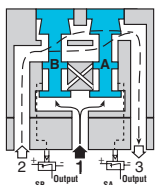

Conditions at Start

The Safety exhaust valve starts with inlet 1 closed to outlet 2 by both valve elements A and B. Outlet 2 is open to exhaust 3. Pressure signals at both sensors SA and SB are exhausted and contacts 1 and 2 of sensors SA and SB are connected. The normally closed sensors both provide voltage feedback signals to the external monitoring system.

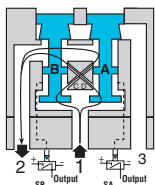

Normal Operation

During normal operation the two solenoids are simultaneously energized which actuates both pilots and causes valve elements A and B to shift. Inlet 1 is then connected to outlet 2 via crossflow passages C and D. Exhaust 3 is closed. Sensing pressure signals go to each pressure sensor and become equal to inlet pressure. Both sensors contacts open and no voltage signals are provided to the external monitoring system. This indicates that both sides of the valve actuated as expected.

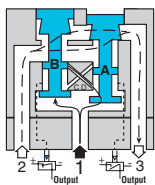

Detecting a Malfunction

A malfunction in the system or the valve itself could cause one valve element to be open and the other closed. Air then flows past the inlet poppet on valve element A, into crossflow passage D, but is substantially blocked by the spool portion of element B. The large size of the open exhaust passage past element B keeps the pressure at the outlet port below 2% of inlet pressure. Full sensing air pressure from side A goes to sensor SA, and a reduced pressure goes to sensor SB. This full pressure signal causes SA to open. Sensor SB, with a reduced pressure signal, does not open. An external monitoring system can detect the malfunction by monitoring the outputs of the SA and SB sensors. The external monitor system must then react accordingly by shutting down the power to the valve solenoids and any other components deemed necessary to stop the machine.

Machinery Directive - Overview

The Machinery Directives' goal is to protect people and the environment from accidents caused from all types of machinery. Based on the standard EN 13849 [safety of machines; safety-related parts of control systems] these standards build the procedure to assess safety-related control systems.

Required Performance Level (PLr) based on a risk assessment are now commonly used to determine the safety level required for the controls system, for the application of machinery.

Performance Level (PL) based on the original B, 1,2,3,4 safety categories, diagnostic capabilities, Mean time to dangerous failure (MTTFd), and common cause failure (CCF), define safety levels of a given safety function. This ensures that safety is not just focused on component reliability, but instead introduces common sense safety principles such as redundancy, diversity, and fail-safe behavior of safety related control parts.

The new EN 13849 standards of the Machinery Directive dictates the machine is safe when the Performance Level of the safety control circuit is equal to or greater than the Required Performance Level of the application. When determining the required performance level, the greater the risk, the higher the requirements of the control system.

$$PLr \leq PL$$

Determining PLr According to EN 13849-1

The level of each hazardous situation is classified in five Performance levels from a to e. With PL a the control functions contribution to risk reduction is low, while at PL e it is high. The risk graph above can be used as a guideline to determine the required performance level PLr for safety function.

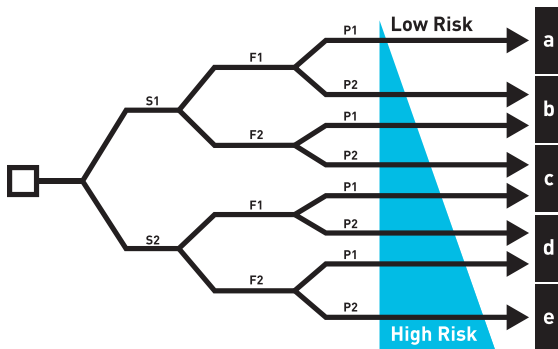

Risk Parameters

(S) Severity of injury

- S1 Slight (normally reversible injury)
- S2 Serious (normally irreversible injury, or death)

(F) Frequency and / or duration of exposure to hazard

- F1 Seldom to less often and / or brief
- F2 Frequent to continuous and / or long

(P) Possibility of avoiding the hazard

- P1 Possibility of avoiding the hazard
- P2 Scarcely ever possible

Determining PL According to EN 13849-1

Determining the MTTF_d = Mean Time To Dangerous Failure

Determining the PL = Performance Level	a								10 ⁻⁴ ≤ PFH _d < 10 ⁻³	Determining the SIL = Safety Integrity Level	
	b								3 X 10 ⁻⁴ ≤ PFH _d < 10 ⁻³		
	c								10 ⁻⁴ ≤ PFH _d < 3 X 10 ⁻³	1	
	d								10 ⁻² ≤ PFH _d < 10 ⁻¹	2	
	e								10 ⁻¹ ≤ PFH _d < 10 ⁻⁰	3	
		DC < 60% None	60% ≤ DC < 90% None	90% ≤ DC < 99% Low	90% ≤ DC < 99% Medium	60% ≤ DC < 90% Low	60% ≤ DC < 90% Medium	90% ≤ DC < 99% Medium	99% ≤ DC High		
		Cat. B	Cat. 1	Cat. 2	Cat. 3	Cat. 3	Cat. 3	Cat. 4			
		CCF not relevant		CCF ≥ 65%							

■ Low mttfd
■ Medium mttfd
■ High mttfd

Categories Defined by EN 13849-1

Category	Summary
Category B	When a fault occurs it can lead to the loss of the safety function.
Category 1	Same that Category B, but loss of the safety function is less likely thanks to a good MTTFd of each channel.
Category 2	System behavior allow that the occurrence of a fault can lead to the loss of the safety function between the checks; the loss of the safety function is detected by the check.
Category 3	A single fault in any of safety related parts does not lead to the loss of the safety function. Whenever reasonably possible the single fault shall be detected at or before the next demand upon the safety function. (Means redundancy)
Category 4	Same as Category 3, but if detection of single fault is not possible on or before the next demand upon the safety, an accumulation of these undetected faults shall not lead to the loss of the safety function. (Means redundancy & check)

Electronic Proportional Regulator Numbering System

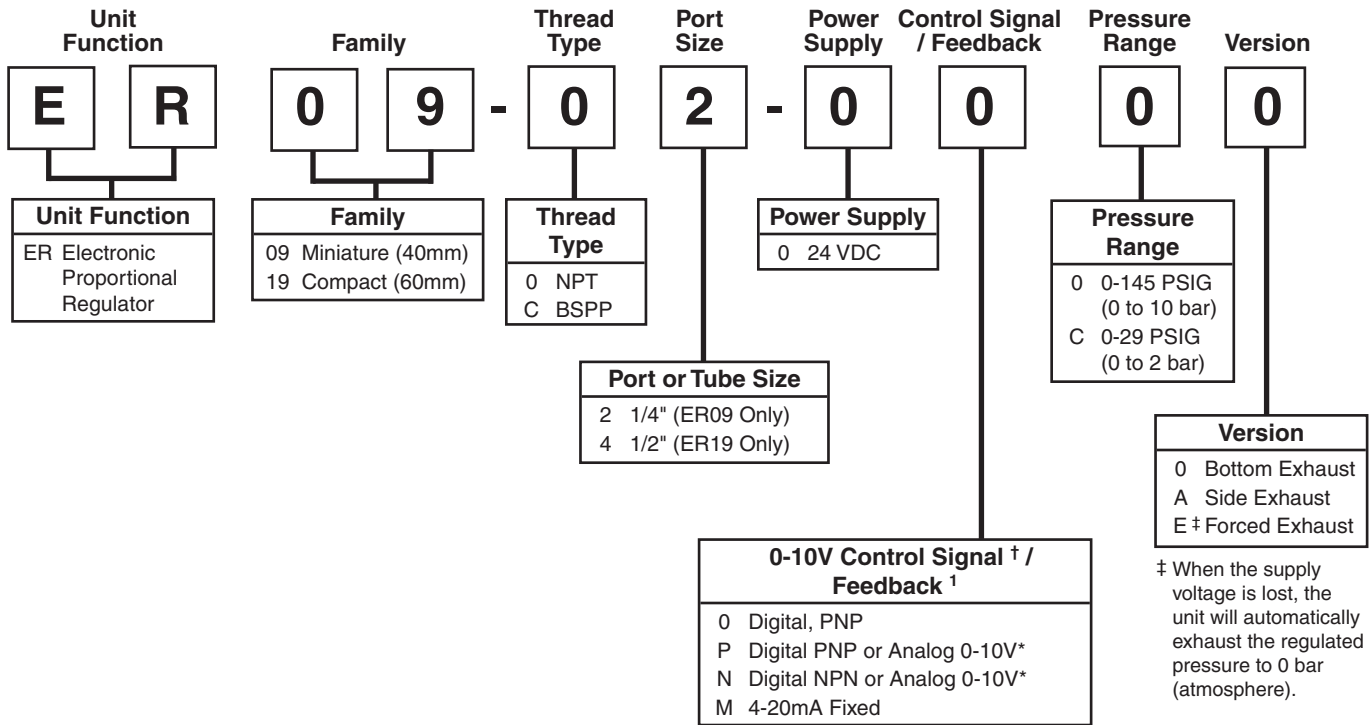

† All products have a 0-10V control signal, this is switchable to 4-20mA by means of parameter 4.

* Selectable by means of Parameter 6

- 1 0) Digital PNP output only, no analog output selectable
- P) Digital PNP and analog 0-10V outputs selectable by means of parameter 6 (factory defaults 0-10V)
- N) Digital NPN and analog 0-10V outputs selectable by means of parameter 6 (factory defaults 0-10V)
- M) Analog 4-20mA output only

Electronic Proportional Regulator ER09, ER19

 = "Most Popular"

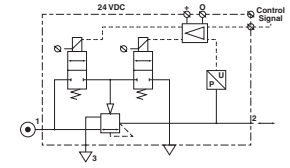

ER09

ER19

Materials

Magnet Core	Steel
Solenoid Valve Poppet	FPM
Solenoid Valve Housing	Techno Polymer
Regulator Body (ER09 / ER19)	Aluminum
Regulator Top Housing	Nylon
Valve Head	Brass & NBR
Remaining Seals	NBR

Features

- Very fast response times
- Accurate output pressure
- Micro parameter settings
- Selectable I/O parameters
- Quick, full flow exhaust
- LED display indicates output pressure
- No air consumption in steady state
- Multiple mounting options
- Protection to IP65

Accessories

- Cable (M12, 4-Pin connection w/2m cable)CB-M12-4P-2M
- DIN Rail Mounting Kit – ER09 P3HKA00ML
- Foot Bracket Mounting Kit – ER09 P3HKA00MC
- L-Bracket Mounting Kit – ER19 P3KKA00ML
- Foot Bracket Mounting Kit – ER19 P3KKA00MC
- Seal Kit (valve seat, cover seal) 3538200
- Valve Kit (2 valves, screws, cover seal) 3538100

Ordering Information

Port Size	Order Code	Control Signal	Output Signal	Output Pressure
1/4	ER09-02-00C0	0 - 10 V	Digital PNP Only	0-29 PSIG (0 -2 bar)
1/4	ER09-02-0000	0 - 10 V	Digital PNP Only	0-145 PSIG (0 -10 bar)
1/4	ER09-02-0PC0	0 - 10 V	Digital PNP or 0-10V	0-29 PSIG (0 -2 bar)
1/4	ER09-02-0P00	0 - 10 V	Digital PNP or 0-10V	0-145 PSIG (0 -10 bar)
1/4	ER09-02-0NC0	0 - 10 V	Digital NPN or 0-10V	0-29 PSIG (0 -2 bar)
1/4	ER09-02-0N00	0 - 10 V	Digital NPN or 0-10V	0-145 PSIG (0 -10 bar)
1/4	ER09-02-0MC0	0 - 10 V	4-20mA Analog Only	0-29 PSIG (0 -2 bar)
1/4	ER09-02-0M00	0 - 10 V	4-20mA Analog Only	0-145 PSIG (0 -10 bar)
1/2	ER19-04-00C0	0 - 10 V	Digital PNP Only	0-29 PSIG (0 -2 bar)
1/2	ER19-04-0000	0 - 10 V	Digital PNP Only	0-145 PSIG (0 -10 bar)
1/2	ER19-04-0PC0	0 - 10 V	Digital PNP or 0-10V	0-29 PSIG (0 -2 bar)
1/2	ER19-04-0P00	0 - 10 V	Digital PNP or 0-10V	0-145 PSIG (0 -10 bar)
1/2	ER19-04-0NC0	0 - 10 V	Digital NPN or 0-10V	0-29 PSIG (0 -2 bar)
1/2	ER19-04-0N00	0 - 10 V	Digital NPN or 0-10V	0-145 PSIG (0 -10 bar)
1/2	ER19-04-0MC0	0 - 10 V	4-20mA Analog Only	0-29 PSIG (0 -2 bar)
1/2	ER19-04-0M00	0 - 10 V	4-20mA Analog Only	0-145 PSIG (0 -10 bar)

ER09 Bottom Exhaust Version

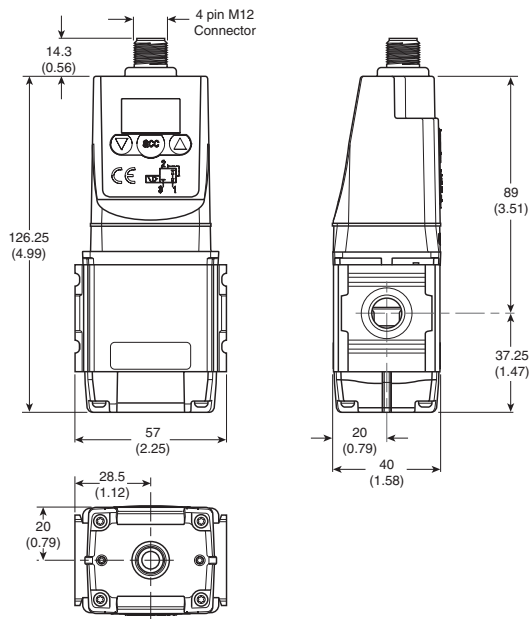

ER19 Bottom Exhaust Version

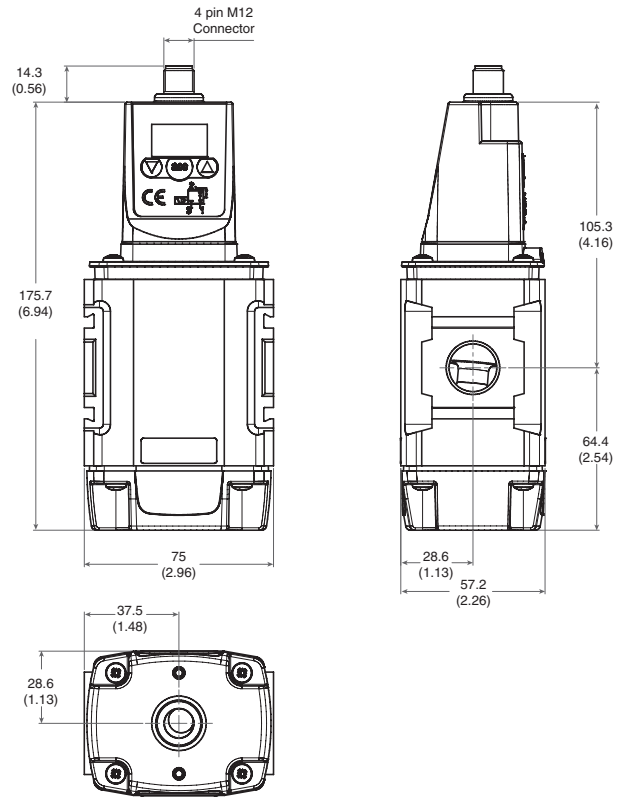

L-Bracket

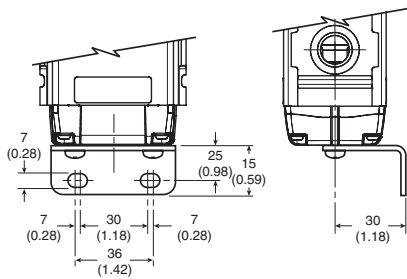

L-Bracket

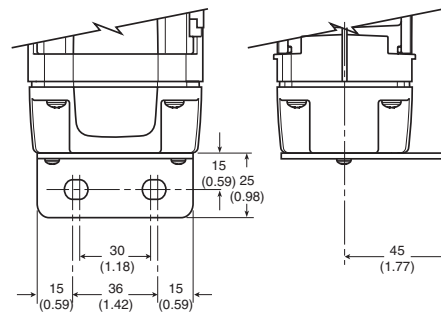

Foot Bracket

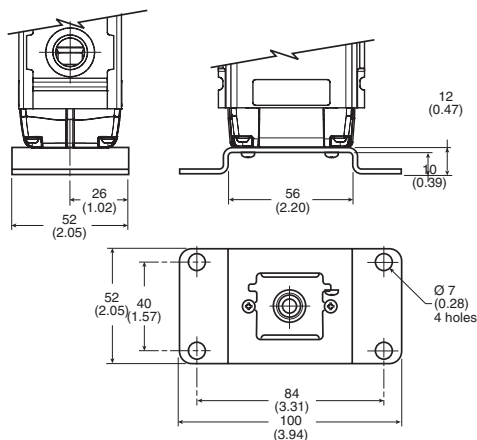

Foot Bracket

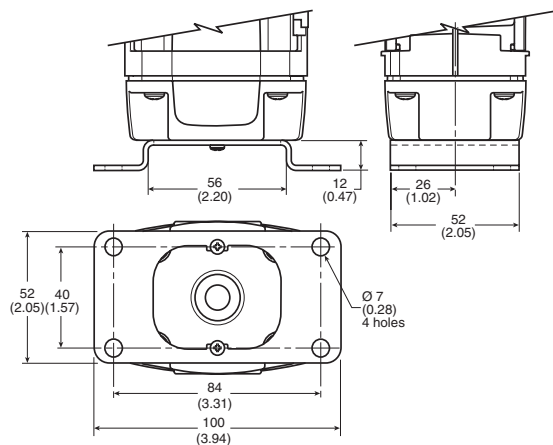

Dimensions are in mm (Inches)

Energy Saving

Low Watt Power Consumption
 No Unnecessary Loss of Air in Steady State

Man-Machine Interface

High Visibility LED Display
 Easy to Read Characters
 All Controls on the Same Face

Total Flexibility

User Friendly and Easily Accessible Software Controls
 One Basic Unit Suits All Customer Requirements -
 0-10V Control Signal Standard
 4-20mA Control Signal Software Selectable
 Modular Mounting
 10 bar & 2 bar Version

Special Applications

Clean Line Design
 Suitable for Washdown: IP65
 Forced Exhaust Option Available
 4 Output Signal Versions Available

Compact and Light Weight

40 & 60 mm Body Sizes
 Light Weight Aluminum Bodies

Flexible Mounting Options

Stand-alone or Modular Mounting
 Foot Bracket Mounting
 DIN-Rail Mounting



Outstanding Performance

Very Fast Response Times
 Full Flow Exhaust
 Excellent Linearity
 High Flow

Generic Industries



The new Proportional Regulator is designed to quickly and accurately adjust and maintain a set output pressure.

The unit will operate regardless of flow, in response to an electronic control signal. The media can be compressed air or an inert gas.

Applications for this technology are virtually unlimited; from paint spray control, paper manufacturing and printing to weaving and laser cutting control; in fact anywhere that requires accurate remote pressure control.

Automation

In the field of general automation, the need to control processes or movement via electronic signals is of paramount importance. The Proportional Regulator unit provides the facility to incorporate pressure control into a fully integrated control system.



Packaging and Food



The Packaging and Food industry provides another ideal area for application of the Electronic Proportional Regulator, where fine control of tension on wrapping foils and paper is required. The degree of control and the ability to manually change parameters makes this unit ideally suited to the varying requirements of this industry.

Automotive

Applications for this innovative product in the Automotive industry can be seen in major manufacturers' "body-in-white" lines.

The control of clamping and welding forces during panel assembly is an ideal application, also accurate control in paint dipping and spraying can be achieved.

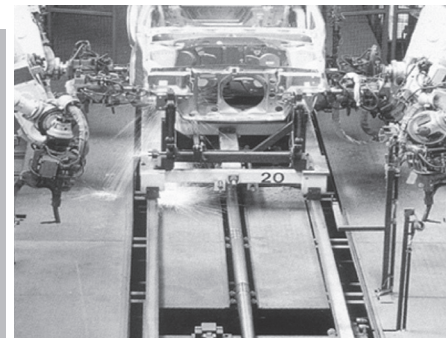

Why Proportional Technology ?

The Difference Between Open or Closed Circuit Control

Standard pressure regulators go a long way towards meeting customers needs. In most cases these regulators work well in general pneumatic and automation applications. However, sometimes the application calls for more precise pressure control. The effects of time, cycling, input, back pressure or pressure and flow variation can all cause inconsistencies in pneumatic systems. Proportional Regulators are designed to eliminate those inconsistencies.

Open Control Circuit

In a normal pressure regulated control system, the inlet pressure (p_1) is converted into the output pressure (p_2) by the regulator. The set pressure (set value) is usually manually set by adjusting the control knob and in normal circumstances the regulator maintains the output pressure (actual value).

No facility for monitoring the output pressure is provided and there is consequently no way of checking that the set value and the actual value are the same. Also, no account is taken of external influences such as air consumption by the system, which can drastically alter the actual value.

Closed Loop Control Circuit

The input signal (Electronic Control Signal) is converted into the output value (P2 Output Pressure). This output value is continuously measured and compared with the input signal. If they are different, the unit adjusts the output value to correspond to the set value, to close the loop.

Proportional Pressure Regulators

The Proportional Regulators provide all the advantages of a closed circuit regulated system. When a set value is defined via the input signal (e.g. 0-10 V), the pressure regulator sets the corresponding output pressure (e.g. 0-150 PSI/0-10 bar). At the same time the integrated pressure sensor measures the actual pressure at the unit's outlet (actual value).

If the electronic regulation system finds that the actual value has deviated from the set value, it immediately corrects the actual value. This is a continuous process ensuring fast, accurate pressure regulation.

Typical Application in Automotive Body in White Welding Pressure Control

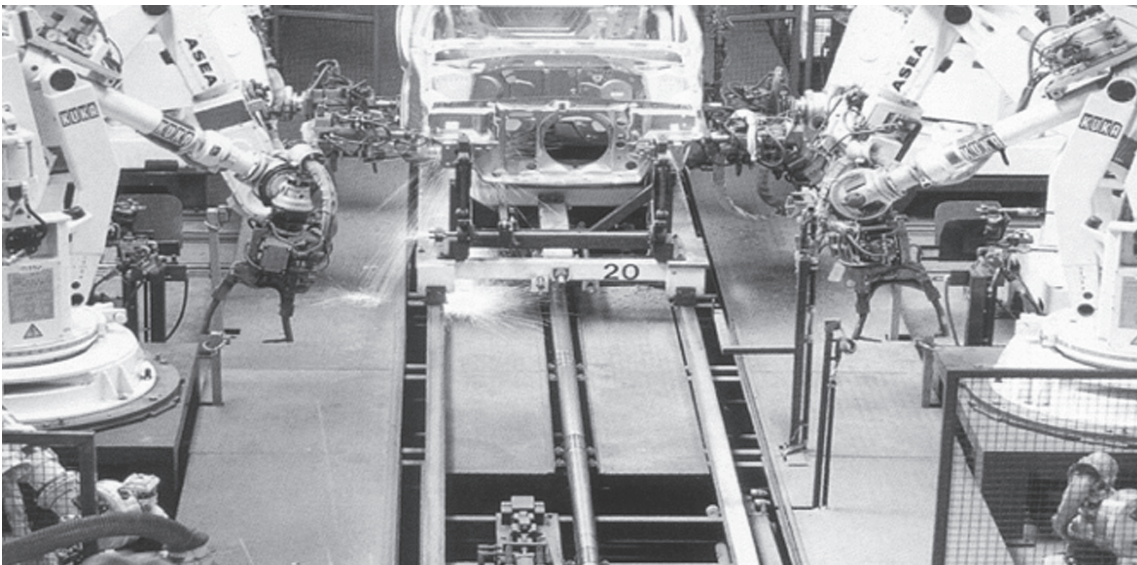

Pneumatics

Working Media

Compressed air or inert gasses, filtered to 40µ.

Operating Pressure

	Max. Operating Pressure
2 bar unit	3 bar (43.5 PSI)
10 bar unit	10.5 bar (152 PSI)
Min. Operating Pressure	P2 Pressure + 0.5 bar (7.3 PSI)

Pressure Control Range

Available in two pressure ranges, 0-2 bar (0-29 PSI) or 0-10 bar (0-145 PSI). Pressure range can be changed through the software at all times. (parameter 19)

Temperature Range

32°F to 122°F (0°C to 50°C)

Weight

ER09	0.64 lbs (.291 kg)
ER19	1.42 lbs (.645 kg)

Air Consumption

No consumption in stable regulated situation.

Display

The regulator is provided with a digital display, indicating the output pressure, either in PSI or bar.

The factory setting is as indicated on the label, can be changed through the software at all times (parameter 14).

Electronics

Supply Voltage

24 VDC +/- 10%

Power Consumption

1.1 W with unloaded signal outputs

Current Consumption

Max. 200 mA with no load

Control Signals

The electronic pressure regulator can be externally controlled through an analog control signal of 0-10 V, adjustable to 4-20 mA via parameter 4.

Connections

Central M12 male connector 4-pole.

The electrical connections are as follows:

Pin No.	Function	Color	
1	24 V	Supply	Brown
2	0 to 10 V	Control Signal Ri = 100k Ω	White
	4 to 20mA	Control Signal Ri = 500 Ω	
3	0 V (GND)	Supply	Blue
4	24 V	Alarm Output Signal	Black

Schematic

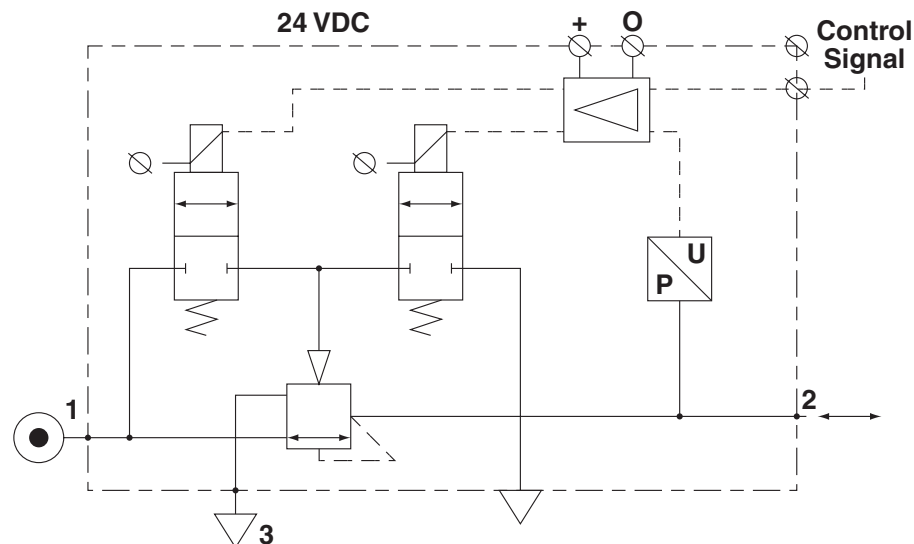

Technical Information

Dead Band

The dead band is preset at 1.3% of Full Scale*, adjustable via parameter 13.

Accuracy

Linearity = < 0.3% of Full Scale.*

Proportional Band

The proportional band is preset at 10% of Full Scale.*

Fail Safe Operation

- If the ER09 / ER19 unit has an “0” or “A” in the 12th digit of the model number
 - When the supply voltage drops, the electronic control reverts to the fail safe mode. The last known output pressure is maintained at approximately the same level depending upon air consumption. The digital display indicates the last known pressure setting.
 - When the supply voltage is reinstated to the correct level, the valve moves from the fail safe mode and the output pressure immediately follows the control signal requirement. The display indicates the actual output pressure.
 - Note: In the event of loss of both power and inlet pressure the unit will exhaust downstream pressure.
- If the ER09 / ER19 unit has an “E” in the 12th digit of the model number
 - When the supply voltage drops, the electronic control reverts to “Forced Exhaust Mode” and will automatically exhaust the downstream (regulated) pressure.
 - When the supply voltage is reinstated to the correct level the unit will return to normal operation and follows the control signal requirement. The display indicates the actual pressure.
- If the unit has been programmed in manual mode (not with a control signal) the unit will EXHAUST and the regulator will need to be reset when power is applied.

Full Exhaust

Complete exhaust of the regulator is defined as $P_2 \leq 1\%$ Full Scale

* Full Scale (F.S.)

For 2 bar versions this will be 2 bar, for the 10 bar version full scale will be 10 bar.

Degree of Protection

IP65

EU Conformity

CE: standard

EMC: according to directive 89/336/EEC

The new pressure regulator is in accordance with:

EN 61000-6-1:2001
EN 61000-6-2:2001
EN 61000-6-3:2001
EN 61000-6-4:2001

These standards ensure that this unit meets the highest level of EMC protection.

Mounting Position

Preferably vertical, with the cable gland on top.

Advanced Functionality

Pilot Valve Protection

When the required output pressure can not be achieved due to lack of input pressure, the unit will open fully and will display “NoP”. Approximately every 10 seconds the unit will retry. The output pressure will then be approximately equal to the inlet pressure. As soon as the input pressure is back on the required level, the normal control function follows.

Safety Exhaust

Should the control signal fall below 0.1 volts, the valve will automatically dump downstream system pressure.

Input Protection

The unit has built-in protection against failure and burnout resulting from incorrect input value, typically:

The 24v DC supply is directly connected to the setpoint input, the display will show ‘OL’, as an overload indication. The unit will need to be rewired and when correctly connected will operate normally.

The overload indicator ‘OL’ will also appear should the wrong input value be applied or the wrong input value be programmed: 4 - 20m instead of 0 - 10V. To correct this a different set point value should be input or the unit reprogrammed to correct the set point value acceptance. (via parameter 4).

Response Times

Response time	ER09	ER19
2 to 4 bar	25 msecs	35 msecs
1 to 6 bar	55 msecs	135 msecs
4 to 2 bar	70 msecs	85 msecs
6 to 1 bar	80 msecs	225 msecs

To fill volume of:

100cm³ - ER09

330cm³ - ER19

connected to the outlet of the regulator.

Settings

The regulator is pre-set at the factory. If required, adjustments can be made.

Flow Charts

ER09 Regulator 1/4” Ports

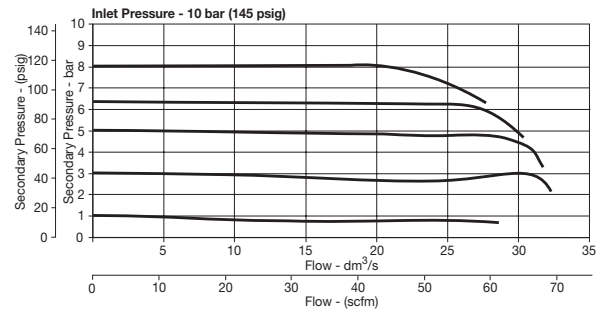

ER19 Regulator 1/2” Ports

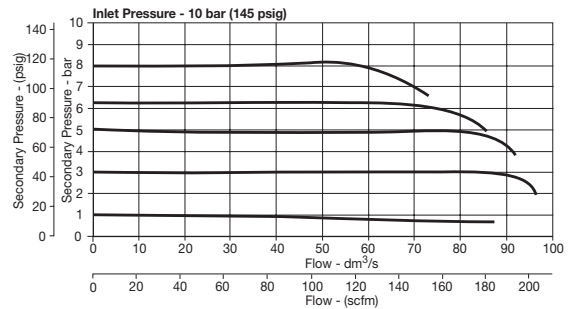

How to Change Parameters

Pressing the Accept key “acc” for more than 3 seconds, will activate parameter change mode. The user can then select the parameters by pressing up or down key. (display will show Pxx). When parameter number is correct, pressing accept again will enter parameter number.(display will show parameter value).

Pressing the up or down key will change the parameter itself. (display will flash indicating parameter editing mode). Pressing the accept key will accept the new parameter value. (all digits will flash whilst being accepted).

After releasing all keys , the next parameter number will be presented on the display. (you may step to the next parameter). When no key is pressed, after 3 seconds the display will show the actual output pressure.

When the unit is initially powered up allow approximately 10 seconds for the unit to “boot-up” before changing parameter settings.

Only parameter numbers 0, 4, 6, 8, 9, 14, 18, 19, 20, 12, 13 and 21 are accessible to edit. All other parameters are fixed.

Manual mode:

When keys DOWN and UP are pressed during startup, (connecting to the 24V power supply) manual mode is activated. This means that the user is able to in/decrease the output pressure of the regulator, by pressing the UP or DOWN key. During this action the display will blink, indicating that the manual mode is activated. After powering up again, the unit will revert back to normal mode.











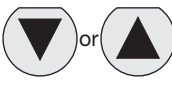

Back to Factory Setting

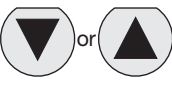
After start up. (Power is on)

Entering this value in parameter 0 will store the calibrated factory data into the working parameters.

(Default calibration data is used)











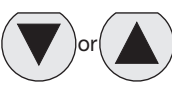

Parameter Number 0 – Reset Back to Factory Settings

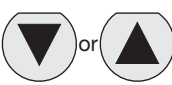
Step	1	2	3	4	5	
 Press	 3-6 seconds					
Until Display Reads			 Flashing Decimal	 Flashing Decimal	 Flashing	
Description	Accesses changeable parameters.	Accesses parameter no. 0.	Displays current parameter value.	Edits parameter. 3 = standard factory settings. If other than 3, use Up or Down Arrow and accept 3	Accepts and saves new parameter setting.	Sequences to next parameter.

Set Control Signal

The unit is factory set for 0-10 V control signal. If 4-20 mA control signal is required, change parameter 4.

Parameter Number 4 – Set Control Signal in Volts or Milliamps

Step	1	2	3	4	5	
 Press	 3-6 seconds					
Until Display Reads			 Flashing Decimal	 Flashing Decimal	 Flashing	
Description	Accesses changeable parameters.	Accesses parameter no. 4.	Displays current parameter value. 1 = V 0 = mA	Edits parameter.	Accepts and saves new parameter setting.	Sequences to next parameter.

Set Output Signal

Parameter 6 is used to set the type of output signal to your PLC.
This parameter is used as follows:











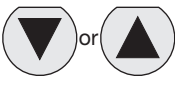

Output Signal option “0” = Digital Output – PNP
 • Factory set at “0” Non Adjustable

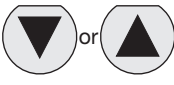
Output Signal option “P” = Digital PNP or Analog 1-10V
 • Factory set at “1” for Analog Signal
 • Convert to Digital PNP by changing parameter to “0” setting

Output Signal option “N” = Digital NPN or Analog 1-10V
 • Factory set at “1” Analog Signal
 • Convert to Digital NPN by changing parameter to “0”

Output Signal option “M” = Analog 4-20 mA
 • Factory set at “2” Non Adjustable

Parameter Number 6 – Set Output Signal











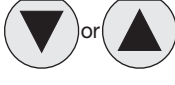

Step	1	2	3	4	5	
Press 	 3-6 seconds					
Until Display Reads			 Flashing Decimal	 Flashing Decimal (Value 0, 1 or 2)	 Flashing	
Description	Accesses changeable parameters.	Accesses parameter no. 6.	Displays current parameter value. 1 = m factory default for P3H with analog options	Edits parameter. 0 = digital (NPN or PNP) 1 = analog 0..10V 2 = analog 4..20 mA	Accepts and saves new parameter setting.	Sequences to next parameter.

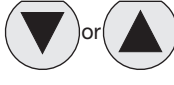
Adjust Span Analog Output Signal

Set value is a % of Full Analog range. As an example for a 0-10V output signal, the original factory setting of 100% will give you an adjustment of 0-10V. If you reset Parameter 8 to 50%, the new output range would be 0-5V or 50% of the full range. In the event that the output signal is to low, in a certain application, you can adjust it by increasing Parameter 8 to a maximum value of 130% of scale.

Note that all values are nominal and that an actual measurement may be required to ensure signal strength.











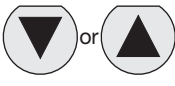

Parameter Number 8 – Adjust Span Analog Output Signal

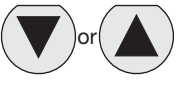
Step	1	2	3	4	5	
Press 	 3-6 seconds					
Until Display Reads			 Flashing Decimal (For 2 bar versions value = 92)	 Flashing Decimal (Value between 0 and 130)	 Flashing	
Description	Accesses changeable parameters.	Accesses parameter no. 8.	Displays current parameter value.	Edits parameter.	Accepts and saves new parameter setting and implements the new analog signal span.	Sequences to next parameter.

Adjust Digital Display

If necessary, adjustments can be made to the digital display when using an external pressure sensor.









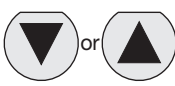

Parameter Number 9 – Adjust Digital Display Value (Pressure Calibration)

Step	1	2	3	4	5	
Press 	 3-6 seconds					
Until Display Reads			 Flashing Decimal	 Flashing Decimal	 Flashing	
Description	Accesses changeable parameters.	Accesses parameter no. 9.	Displays current digital display	Use up or down arrows and accept to adjust the display value if using an external pressure sensor.	Accepts and saves new parameter setting.	Sequences to next parameter.

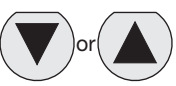
Set Pressure Scale

Units with NPT port threads are supplied with a factory set psig pressure scale. Use parameter 14 to change scale to bar.



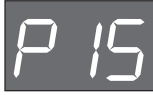





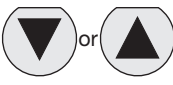

Parameter Number 14 – Set Pressure Scale in psig or bar

Step	1	2	3	4	5	
Press 	 3-6 seconds					
Until Display Reads			 Flashing Decimal	 Flashing Decimal	 Flashing	
Description	Accesses changeable parameters.	Accesses parameter no. 14.	Displays current parameter value. 1 = psig 0 = bar 2 = MPA	Edits parameter.	Accepts and saves new parameter setting.	Sequences to next parameter.

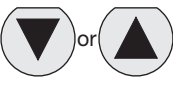
Preset Minimum Pressure

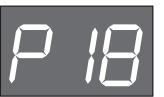
If there is a need for a pre-set Minimum pressure, use parameter 18. (Note: preset pressure is affected by % P19.)

Parameter Number 18 – Set Minimum Preset Pressure

Step	1	2	3	4	5	
Press 	 3-6 seconds					
Until Display Reads			 Flashing Decimal	 Flashing Decimal (value between 0 and 200)	 Flashing	
Description	Accesses changeable parameters.	Accesses parameter no. 18.	Displays current parameter value. Incremental value is: 2 bar unit: $x 2 \text{ mbar} \times \% P19$ 10 bar unit: $x 10 \text{ mbar} \times \% P19$	Edits parameter.	Accepts and saves new parameter setting.	Sequences to next parameter.

Set Pressure Correction











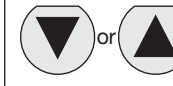

Pressure correction allows the user to set a Maximum pressure as a percentage of secondary pressure F.S.

Example: If F.S. is 10 bar, set parameter 19 to 50 for Maximum preset pressure of 5 bar.

Pressure correction also affects the Minimum preset pressure in parameter 18.

Example: If F.S. is 10 bar and parameter 18 is set to a value of 100 (1 bar), and parameter 19 is set to 50%, then the actual Minimum preset pressure seen is 0.5 bar.

Parameter Number 19 – Set Maximum Preset Pressure











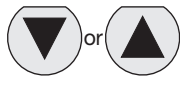

Step	1	2	3	4	5	
Press 	 3-6 seconds					
Until Display Reads			 Flashing Decimal	 Flashing Decimal (value between 0 and 100)	 Flashing	
Description	Accesses changeable parameters.	Accesses parameter no. 19.	Displays current parameter value. Incremental value is: % of F.S.	Edits parameter.	Accepts and saves new parameter setting.	Sequences to next parameter.

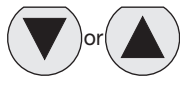
Behavior Control

The regulation speed of the pressure regulator can be modified by means of one parameter. (P 20)

The value in this parameter has a range from 0-5. A higher value indicates slower regulation speed, but will be more stable.

Parameter Number 20 – Set Behavior Control











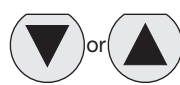

Step	1	2	3	4	5	
Press 	 3-6 seconds					
Until Display Reads			 Flashing Decimal	 Flashing Decimal (value between 0 and 5)	 Flashing	
Description	Accesses changeable parameters.	Accesses parameter no. 20.	Displays current parameter value.	Edits parameter 0 = custom set* 1 = fastest (narrow proportional band) 2 = fast 3 = normal 4 = slow 5 = slowest (proportional band is broad)	Accepts and saves new parameter setting.	Sequences to next parameter.

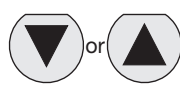
* When the value 0 is entered, you are able to create your own custom settings true parameters 12, 13 and 21.

Fine Settings Set Proportional Band











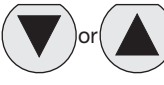

Proportional band is used for setting the reaction sensitivity of the regulator. The displayed value is X 10 mbar and has a range between 50 (0.5 bar) and 250 (2.5 bar).

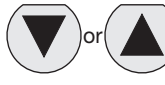
Parameter Number 12 – Set Proportional Band (P20 Must be Set to 0)











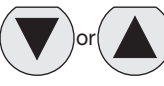

Step	1	2	3	4	5	
Press 	 3-6 seconds					
Until Display Reads			 Flashing Decimal	 Flashing Decimal (value between 50 and 250)	 Flashing	
Description	Accesses changeable parameters.	Accesses parameter no. 12.	Displays current parameter value. Incremental value is: x 10 mbar	Edits parameter.	Accepts and saves new parameter setting.	Sequences to next parameter.

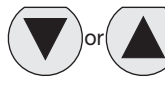





Set Deadband

Deadband is the Minimum limit of accuracy at which the regulator is set for normal operation. The displayed value is X 10 mbar and has a range between 4 (40 mbar) and 40 (400 mbar).

Parameter Number 13 – Set Deadband (P20 Must be Set to 0)						
Step	1	2	3	4	5	
Press 	 3-6 seconds					
Until Display Reads			 Flashing Decimal	 Flashing Decimal (value between 4 and 40)	 Flashing	
Description	Accesses changeable parameters.	Accesses parameter no. 13.	Displays current parameter value. Incremental value is x 10 mbar	Edits parameter.	Accepts and saves new parameter setting.	Sequences to next parameter.

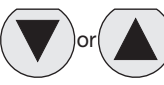
Proportional Effect

Parameter Number 21 – Set Proportional Effect (P20 Must be Set to 0)						
Step	1	2	3	4	5	
Press 	 3-6 seconds					
Until Display Reads			 Flashing Decimal	 Flashing Decimal (value between 5 and 100)	 Flashing	
Description	Accesses changeable parameters.	Accesses parameter no. 21.	Displays current parameter value.	Edits parameter. 5 = fastest regulation 100 = slowest regulation.	Accepts and saves new parameter setting.	Sequences to next parameter.

Parameter Number 39 – Displays Current Software Version			
Step	1	2	3
Press 	 3-6 seconds		
Until Display Reads			 Flashing Decimal
Description	Accesses changeable parameters.	Accesses parameter no. 39.	Displays current parameter value. XXX = current software version

Problem	Possible Reason	Solution
Display will not light up	No 24 volts power supply	Check if the wiring is connected according to the schematic wiring diagram
Unit will not, or not correctly respond to given setpoint	Wrong current applied (I.e. Volt instead of mA or mA instead of Volt) Setpoint signal is not stable enough	Change setpoint current or re configure the setpoint current through the software by changing parameter 4 Check wiring if the setpoint signal lead is connected to the right pin within the male M12 connector (should be pin 2) Stabilize setpoint signal input
Display shows NoP.	Unit detects that required output pressure is higher than the supplied pressure No inlet pressure at all	Adjust the inlet pressure to a higher value, preferably 0,5 bar higher than requested output pressure Give lower setpoint value which corresponds to a output pressure lower than the inlet pressure Connect port 1 to the supply pressure
Unit behavior is not considered normal	Faulty settings made in the parameters	Reset the unit to factory settings by using the green key function under parameter 0
Desired pressure can not be reached	Setpoint value to low Pre-set pressure limit has been changed to a lower max. outlet pressure Supply pressure is to low	Increase setpoint value Change max. outlet pressure back to required pressure by changing parameter 19 Increase supply pressure
Secondary side stays pressurized	Setpoint value is higher than 0,1 Volt Pre-set pressure has been enabled to a certain pressure	Lower your setpoint value, preferably to 0 Volts Reset parameter 18 to 0
Display shows unrealistic value	Display maybe configured in the wrong value (bar instead of psi)	Check through parameter 14, if the display value is set on either psi or bar, if necessary change it to the required setting
Unit response time too slow or too quick	Volume behind the unit is either too big or too small	Adjust the regulating speed of the unit through parameter 20
Unit gives too much overshoot	Relation between volume and response me is out of balance	Adjust response time to a higher value through parameter 20, to achieve more accurate behavior
Unit is adjusting / regulating constantly	Air leakage in the system behind the unit Constant changing volume behind the unit "Deadband "area is set too small	Resolve leakage Unit needs to regulate to keep required pressure at the same level Try to minimize the volume changes Enlarge deadband setting through parameter 13 in the software (parameter 20 has to be set to 0 before changing parameter 13)
Can not enter software through touchpad	Unit is currently working/processing Activating time is too short	Make sure that the unit is in steady state while activating the software Hold the accept button for at least 3 seconds
Display indicates 'OL'	Wiring not according to diagram (24 volt connected on the setpoint connection pin) Wrong setpoint value given in relation to programmed setpoint value acceptance	Rewire so that on the setpoint connection pin will be either 0-10v or 4-20mA Change over setpoint value to either V or mA or Reprogram the unit to the correct setpoint value via parameter 4
Any other problem	Please consult factory	

Glossary

Hysteresis – The mechanical limits of accuracy of the unit. The regulator cannot be adjusted within the inherent mechanical limits of the design.

Dead Band – The minimum limit of accuracy at which the regulator is set for normal operation. This band must be equal to, or exceed, the inherent design limits of the regulator or the hysteresis band.

Proportional Band – The band used for setting reaction sensitivity of the regulator. The regulator senses the excursion from the set pressure and adjusts response in relation to the degree of excursion beyond the dead band. This band must exceed the dead band of the unit.

Proportional Effect – The speed at which the unit approaches P2 (secondary pressure).

Sensitivity – The smallest change in the control signal, or feedback signal, to cause a change in regulated output pressure.

Repeatability – a measurement of how consistently the unit can reproduce an output pressure in relation to a specific set pressure.

Linearity – A measure of how closely the relationship of output pressure vs. the control signal deviates from a straight line function.

Dump Valves Q09 / Q19

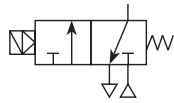

 = "Most Popular"

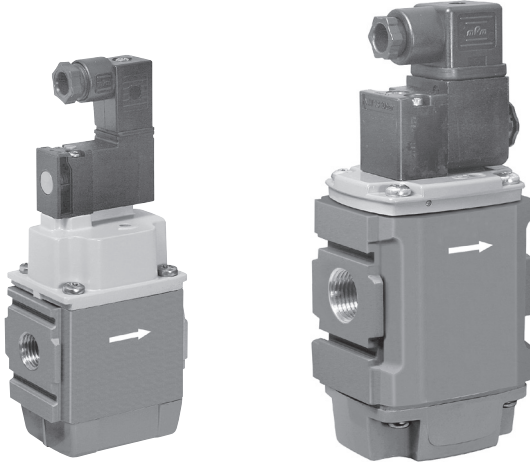

Q09

Q19

Features

- Modular Design with 1/4" or 1/2" Integral Ports (NPT, BSPP & BSPT)
- Provides for the Safe Introduction of Pressure
- The 3-way, 2-position Function Automatically Dumps Downstream Pressure on the Loss of Pilot Signal
- Solenoid or Air Pilot Options
- High Flow & Exhaust Capability
- Silencer Included

Specifications

Flow Capacity*	Q09 1/4 Q19 1/2	36 SCFM (17 dm ³ /s) 108 SCFM (51 dm ³ /s)
Max. Pressure Solenoid operated	150 PSIG (10 bar)	
Max. Pressure Air Pilot operated	250 PSIG (17 bar)	
Min. Operating Pressure	44 PSIG (3 bar)	
Temperature Max.† Solenoid Operated	14°F to 122°F (-10°C to 50°C)	
Temperature Max.† Air Pilot Operated	-4°F to 176°F (-20°C to 80°C)	
Air Pilot Port	1/8"	
Exhaust Port	Q09 - 1/4" / Q19 - 1/2"	
Weight	1/4" 120VAC	0.8 lbs (0.37 kg)
	1/4" 24VDC	0.9 lbs (0.41 kg)
	1/4" Air Pilot	0.8 lbs (0.37 kg)
	1/2" 120VAC	1.5 lbs (0.69 kg)
	1/2" 24VDC	2.0 lbs (0.91 kg)
	1/2" Air Pilot	1.9 lbs (0.87 kg)

* Inlet pressure 91 PSIG (6.3 bar). Pressure drop 15 PSID (1 bar).

† Air supply must be dry enough to avoid ice formation at temperatures below +2 C

Snap pressure: Full flow when downstream pressure reaches 50% of the inlet pressure

Materials of Construction

Body	Aluminum
Body Cover	Polyester
Seals	Nitrile NBR

Mounting Brackets

Description	Order code Q09	Order code Q19
L-Bracket mounting kit	P3HKA00ML	P3KKA00ML
Foot bracket mounting kit	P3HKA00MC	P3KKA00MC

Ordering Information

Model Type	Port Size	Description	Order Code
Q09	1/4"	120VAC Solenoid & cable plug	Q09-02-ED00
	1/4"	24VDC Solenoid & cable plug	Q09-02-EC00
	1/4"	External air pilot operated	Q09-02-A000
Q19	1/2"	120VAC 30mm coil & cable plug incl.	Q19-04-ED00
	1/2"	24VDC 30mm coil & cable plug incl.	Q19-04-EC00
	1/2"	External air pilot operated	Q19-04-A000

1/4 Remote Dump Valve

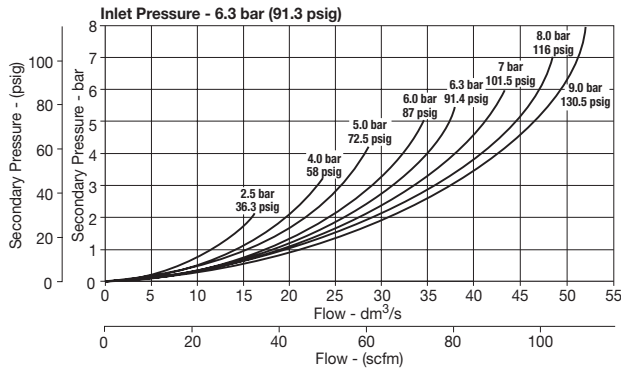

1/2 Remote Dump Valve

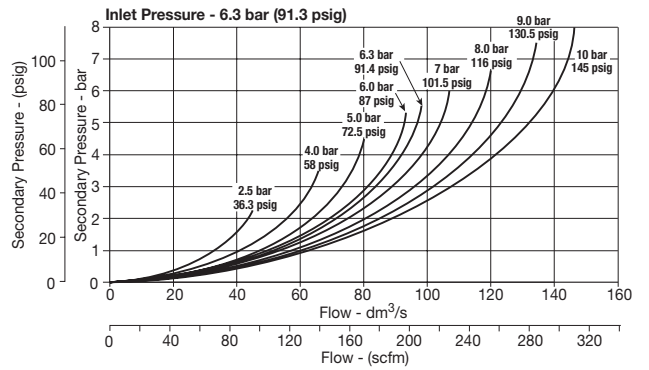

Remotely operated dump valves automatically shut off upstream pressure and exhaust the downstream pressure when the pilot pressure is released. To maintain these units in the open position a pilot supply to the air pilot operated version or an electrical signal to the solenoid operated version must be maintained. The valve will automatically dump when the holding signal is removed.

Dimensions

inches (mm)

Q09

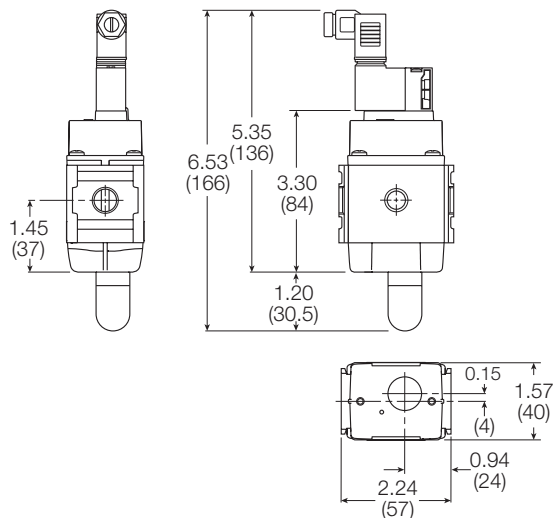

Q19

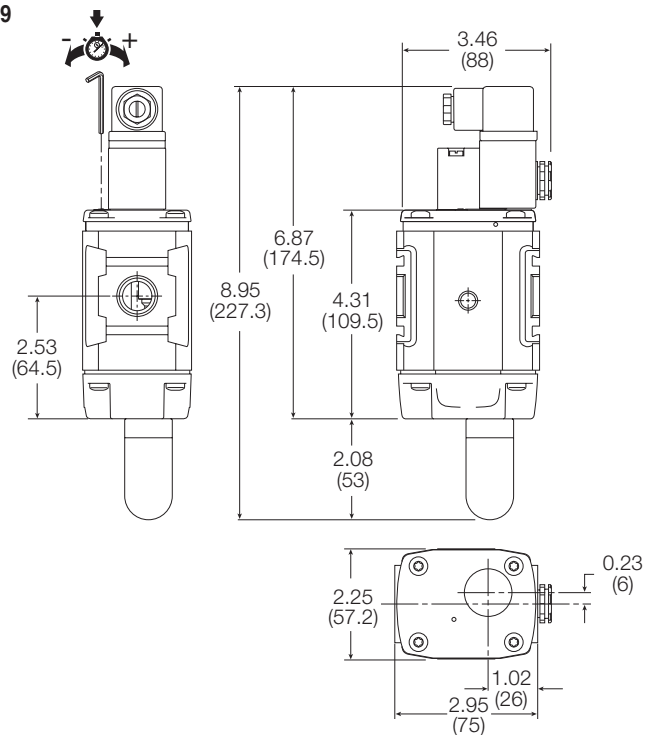

Modular Ball Valve V40, V60, V73

 = "Most Popular"

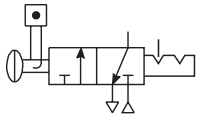

Specifications

Operating Temperature	-40°C to 80°C (40°F to 176°F)		
Max. Supply Pressure	17 bar (246 psi)		
Port Size	NPT / BSPP / BSPT	1/4, 3/8, 1/2, 3/4	
Weight	V40:	0.15 kg (0.33 lbs)	
	V60:	0.36 kg (0.79 lbs)	
	V73:	0.55 kg (1.21 lbs)	

Materials of Construction

Body	Aluminum		
Seals	PTFE		
Ball	V40	Brass	
	V60 / V73	Chrome plated brass	

Features

The Modular Ball Valves provide shut off line pressure with a non-sticking 90° turn handle to prevent unauthorized adjustment. When the inlet pressure is turned off the downstream air pressure vents through the exhaust port. The padlock slide may be assembled on either side. It is recommended that this is assembled after mounting.

The Safety Lockout valves conform to OSHA #29 CFR part 1910 — control of hazardous energy source (lockout / tagout).

Note: This padlock slide is a permanent assembly and may not be removed later

Ordering Information

Model Type	Port Size	Thread Type	Flow SCFM
V40-02-B000B	1/4	NPT	42
V60-03-B000B	3/8	NPT	190
V60-04-B000B	1/2	NPT	258
V73-04-B000B	1/2	NPT	561
V73-06-B000B	3/4	NPT	678

V40

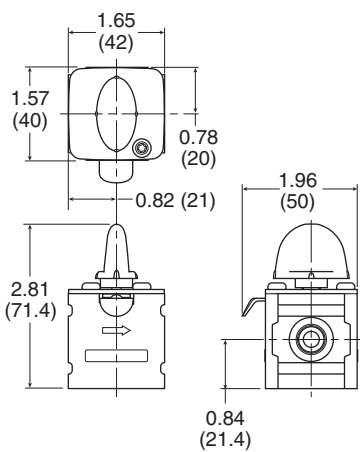

V60

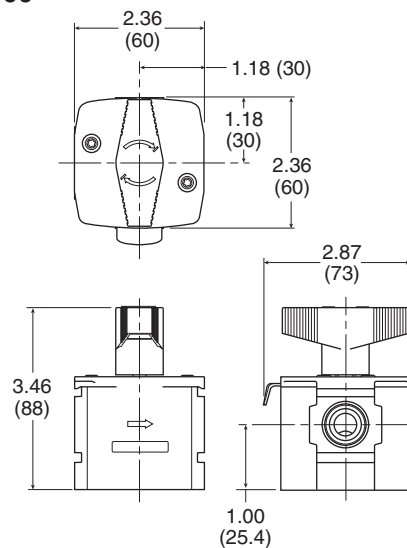

V73

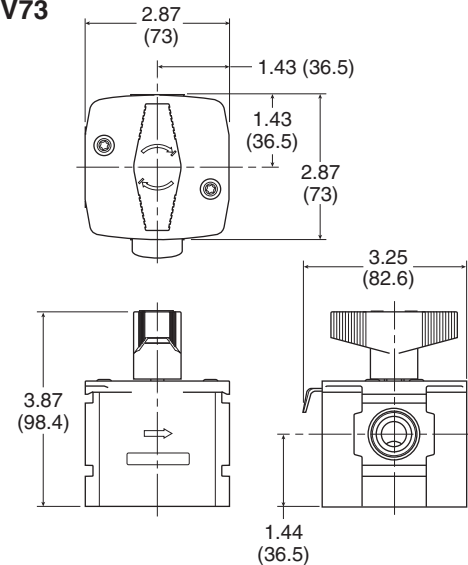

Modular Ball Valve V90

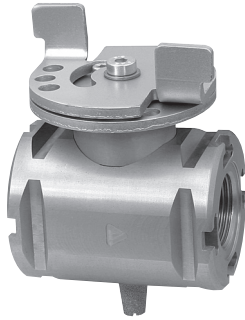

Symbol

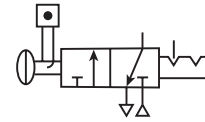

- Positive bubble tight shut-off
- 90° turn handle to prevent unauthorized adjustment
- Padlockable (up to 6 times)
- When the inlet pressure is turned off the downstream vents through the exhaust port

Ball / Lockout Valve shuts off downstream line pressure in the closed position with a 90° turn of the handle. In the closed position, inlet air pressure is blocked and downstream / system air is exhausted through a threaded port. To prevent unauthorized adjustment, the padlock slide may be assembled on either side. It is recommended that this slide is installed after final system assembly.

The Safety Lockout valves conform to OSHA #29 CFR part 1910 – control of hazardous energy source (lockout / tagout).

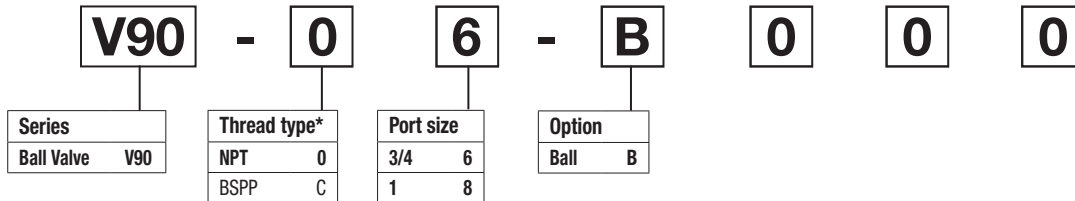

*Note: For 1-1/2" ported unit, please order P3YKA*BCP port block kit separately.
Bold items are most common.

Specifications

Flow capacity	3/4"	333 dm ³ /s (705.6 scfm)
	1"	333 dm ³ /s (705.6 scfm)
Max. pressure air pilot operated	17.5 bar (254 psig)	
Operating temperature	-10°C to 60°C (14°F to 140°F)	
Weight	3/4"	1.1 kg (2.4 lb)
	1"	1.1 kg (2.4 lb)

Material Specifications

Body	Aluminum
Valve ball	Brass / Nickle plated
Handle	Aluminum
Seals	Nitrile NBR
Exhaust silencer	Sintered bronze

Dimensions mm (inches)

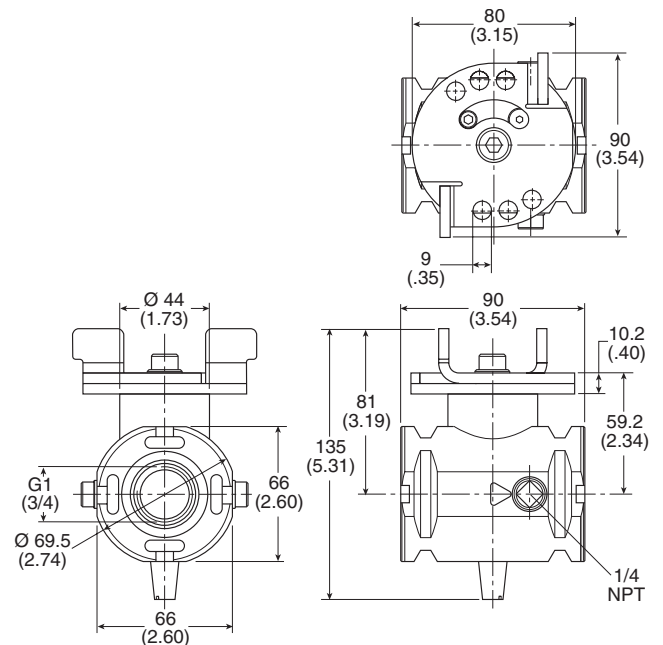

Numbering System

 = "Most Popular"

08 Series Diverter Block

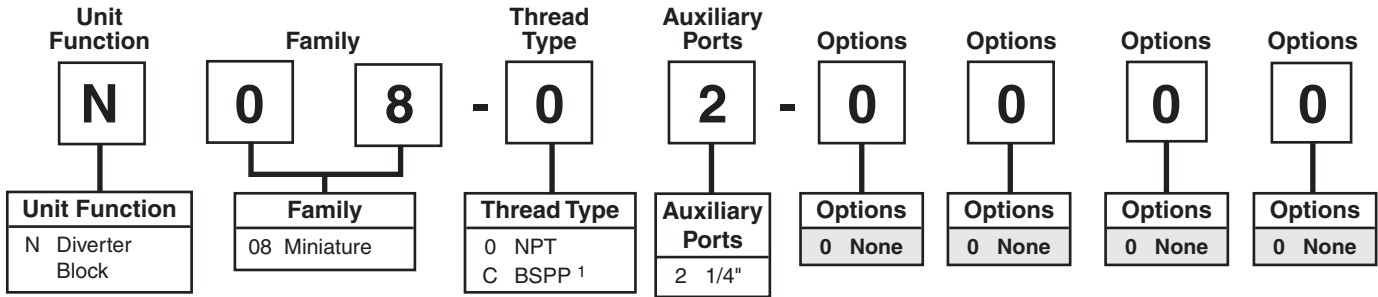

¹ ISO, R228 (G Series)

18 / 28 Series Diverter Block

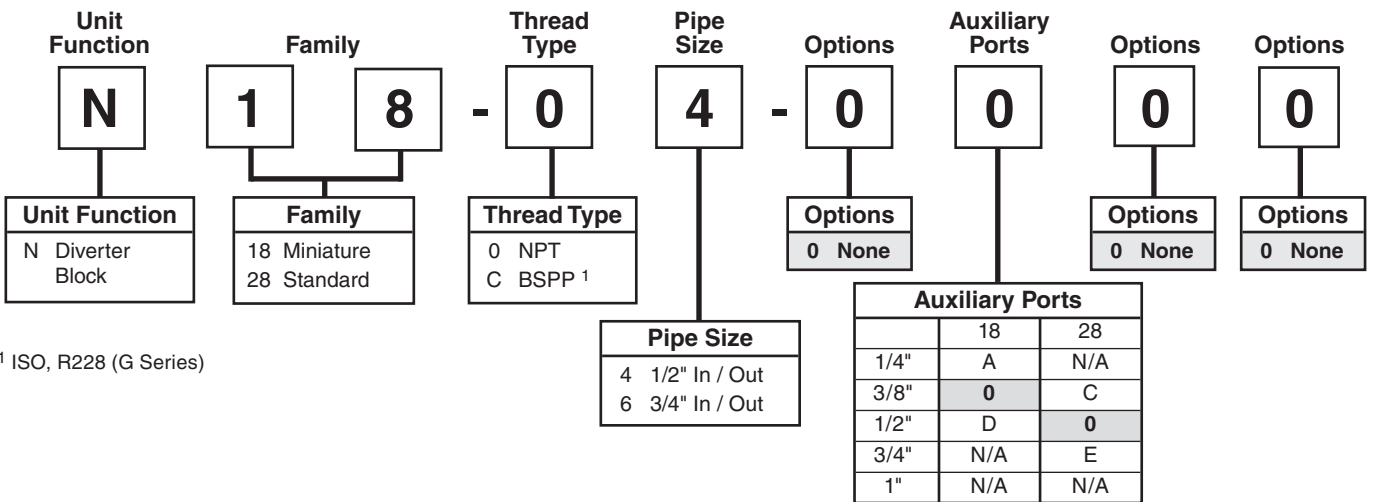

¹ ISO, R228 (G Series)

NJ8 Diverter Block

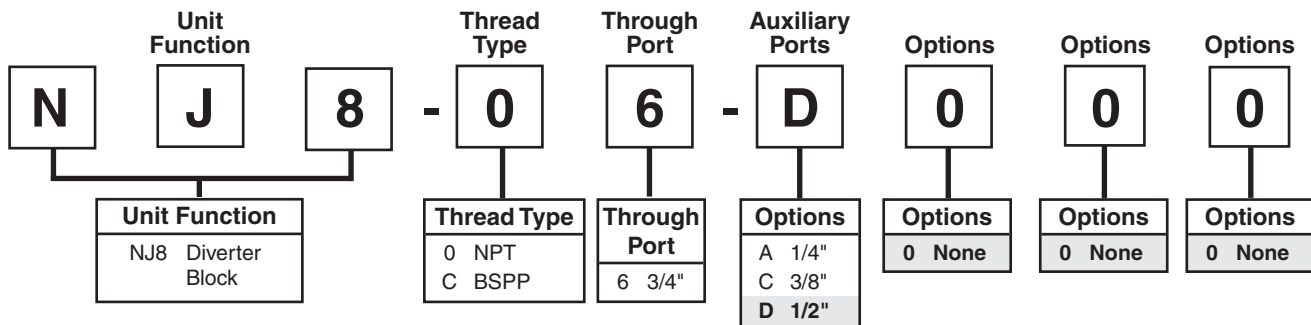

Auxiliary Ports
 2 Each (one top,
 one bottom)

Diverter Block N08

 = "Most Popular"

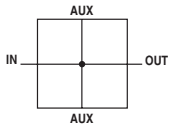

Specifications

Flow Capacity*	1/4	140 SCFM (66.1 dm ³ /s)
Auxiliary Port (2)	NPT / BSPP-G	1/4
Maximum Supply Pressure	300 PSIG (20.7 bar)	
Operating Temperature	32° to 150°F (0° to 65.5°C)	
Port Size (In / Out)	NPT / BSPP-G	1/4
Weight	0.42 lb. (0.19 kg)	

* Inlet pressure 150 PSIG (10.3 bar). Pressure drop 5 PSID (0.3 bar).

Materials of Construction

Body	Zinc
------	------

Features

- Available in 1/4 Threaded Ports
- Modern Design and Appearance
- Light Weight
- Two 1/4 Threaded Auxiliary Ports Standard
- Two Additional Auxiliary Ports Optional
- Can be Mounted Anywhere in the FRL System
- Includes One Pipe Plug

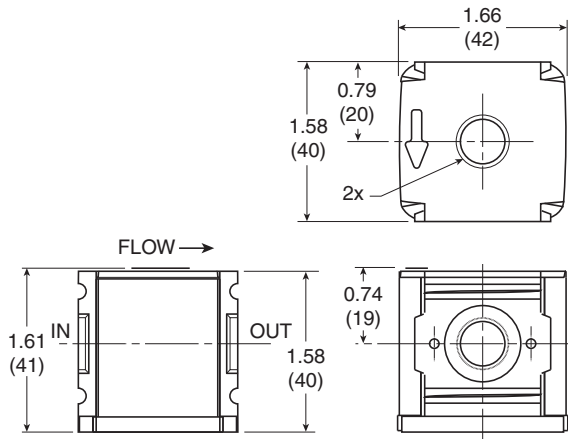
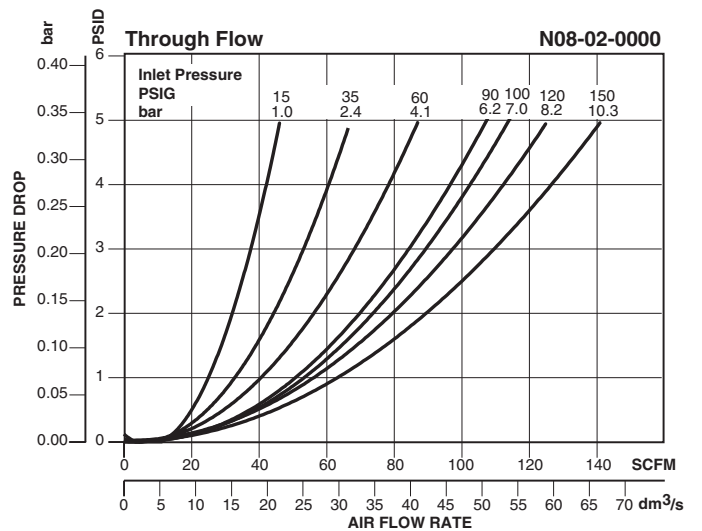

Ordering Information

Model Type	In / Out Port Size	Auxiliary Port Size	Model
N08	1/4	1/4	N08-02-0000

Options - To order an option supplied with the unit model, add the appropriate coded suffix letter in the designated position of the model number.

Diverter Block N18 / N28

 = "Most Popular"

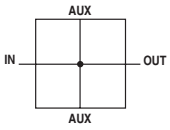

Specifications

Flow Capacity*	N18	1/2	400 SCFM (189 dm ³ /s)
	N28	3/4	647 SCFM (305 dm ³ /s)
Auxiliary Port (2)	NPT / BSPP-G	N18	3/8
		N28	1/2
Maximum Supply Pressure	300 PSIG (20.7 bar)		
Operating Temperature	32° to 150°F (0° to 65.5°C)		
Port Size (In / Out)	NPT / BSPP-G	N18	1/2
		N28	3/4
Weight	N18	0.261 lb. (0.346 kg)	
	N28	0.94 lb. (1.08 kg)	

* Inlet pressure 150 PSIG (10.3 bar). Pressure drop 5 PSID (0.3 bar).

Features

- Available in 1/2 (N18) or 3/4 (N28) Threaded Ports
- Two Auxiliary Ports Standard
- Can be Mounted Anywhere in the FRL System

Ordering Information

Model Type	In / Out Port Size	Auxiliary Port Size	Model
N18	1/2	1/4	N18-04-0A00
		3/8	N18-04-0000
		1/2	N18-04-0D00
N28	3/4	3/8	N28-06-0C00
		1/2	N28-06-0000
		3/4	N28-06-0E00

Options - To order an option supplied with the unit model, add the appropriate coded suffix letter in the designated position of the model number.

Materials of Construction

Body Aluminum

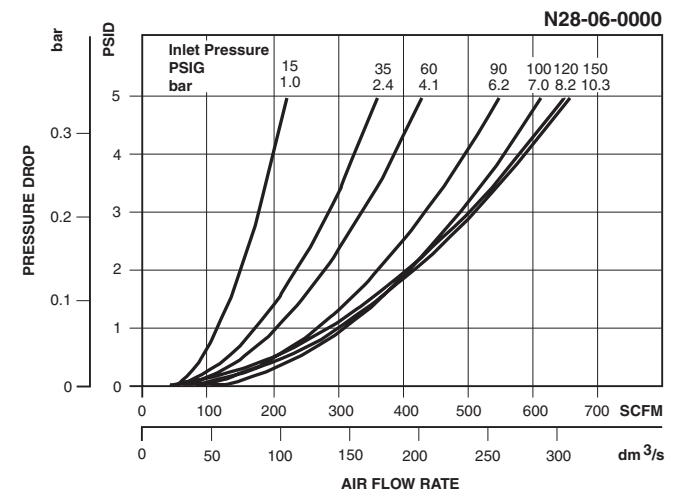
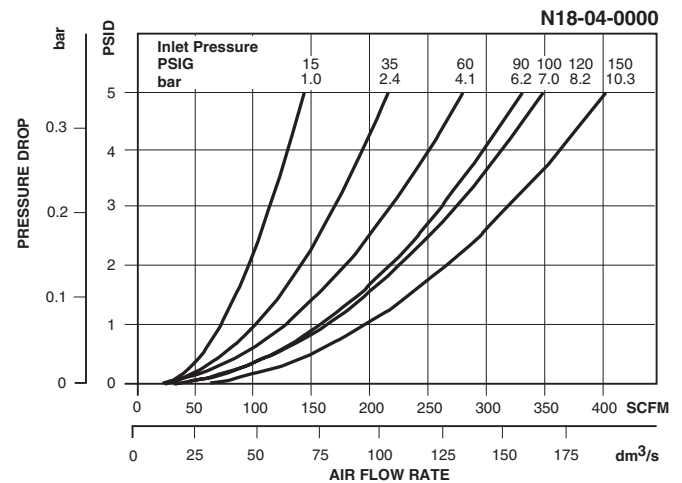
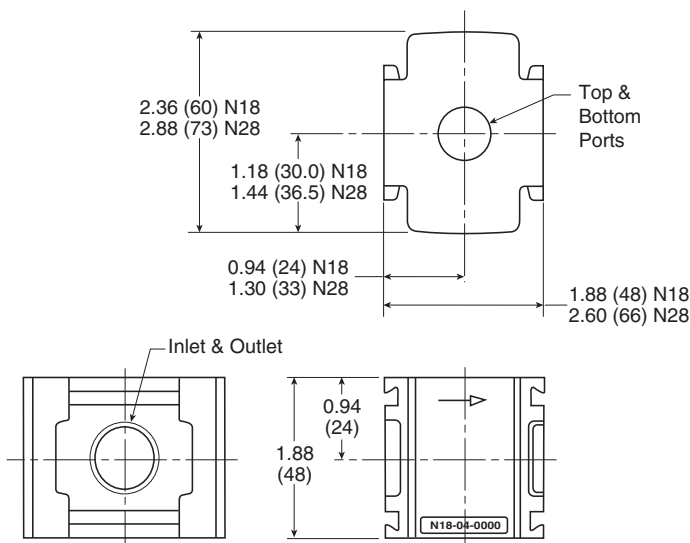

Filter Replacement Element Kits



Model	Type A 5 Micron	Type B 0.5 Micron	Type C 0.01 Micron	Type D Oil Vapor Removing
Particulate Filters				
F08	FRP-96-729	—	—	—
F18	FRP-96-639	—	—	—
F28	FRP-96-653	—	—	—
Coalescing Filters				
M08	—	MSP-96-732	MTP-96-649	MXP-96-222
M18	—	MSP-96-647	MTP-96-646	MXP-96-650
M28	—	MSP-96-649	MTP-96-648	MXP-96-651

Filter Replacement Bowl Kits



Model	Plastic Bowl / Bowl Guard / No Drain	Plastic Bowl / Bowl Guard / Manual Drain	Metal Bowl / Manual Drain	Metal Bowl / Sight Gauge / Manual Drain	Plastic Bowl / Bowl Guard / Automatic Drain	Metal Bowl / Sight Gauge / Automatic Drain
Particulate Filter / Coalescing Filter						
F08 / M08	—	GRP-96-712	GRP-96-714*	—	—	—
F18 / M18	GRP-96-638	GRP-96-634	—	GRP-96-636	GRP-96-635	GRP-96-637
F28 / M28	GRP-96-652	GRP-96-642	—	GRP-96-644	GRP-96-643	GRP-96-645

* Metal bowl does not have sight gauge.

Model	Bowl O-ring (Nitrile)	Bowl O-ring (Fluorocarbon)	Filter Retainer Element Baffle	Manual Drain
Particulate Filter				
F08	GRP-96-710	GRP-96-711	—	—
F18	GRP-96-640	GRP-96-754	FRP-96-641	GRP-96-685
F28	GRP-96-654	GRP-96-755	FRP-96-283	GRP-96-685
Coalescing Filter				
M08	GRP-96-710	GRP-96-711	—	—
M18	GRP-96-640	GRP-96-754	—	GRP-96-685
M28	GRP-96-654	GRP-96-755	—	GRP-96-685

Modular Manifold P3YMA

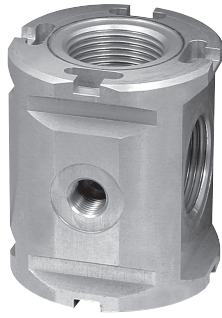

90 Series Manifolds provide up to 4 extra outlet ports. They may be assembled at any position in a combination e.g. before the lubricator to provide oil free take off or at the end of a combination to provide extra outlet ports.

Thread type	Part number
NPT	P3YMA9V0N
BSPP	P3YMA1V0N

Port sizes

Inlet port	Top	Bottom	Front and Back
3/4"	1/8"	1"	1/4"
1"	1/8"	1"	1/4"

Material specifications

Body	Aluminum
Weight	0.7 kg (1.5 lb)

Dimensions mm (inches)

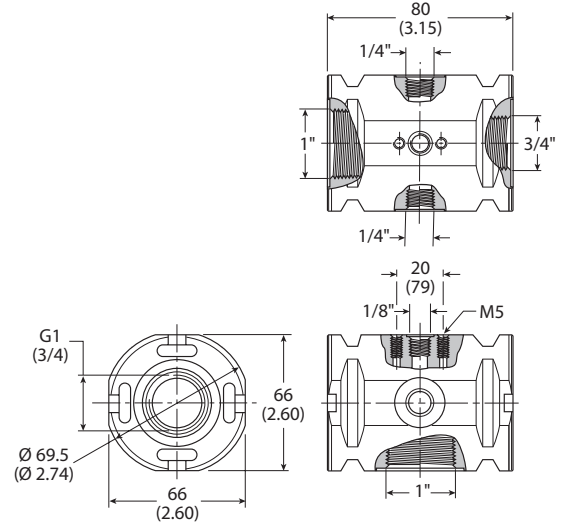

Optional Port Block Kits P3YKA

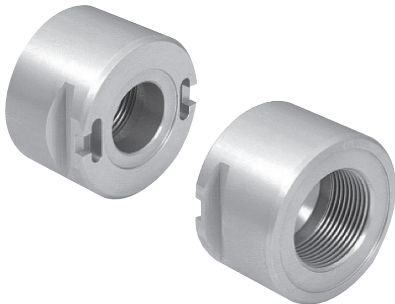

- To change port sizes Port Block Kits are available, they are attached to any unit utilizing the connecting kit.
- Allows assemblies to be removed from a hard piped system.

Material specifications

Body	Aluminum
Weight	0.65 kg (1.43 lb)

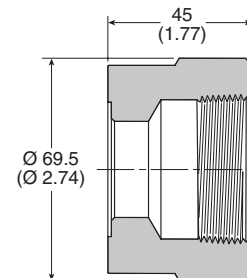

P3YKA **9** **B** **CP**

Basic series	Thread type	Port size
Port Blocks P3YKA	BSPP 1	1-1/2 B
	NPT 9	

Accessories – Filters

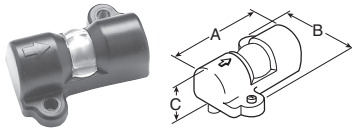

Differential Pressure Indicator
DP8-01-000

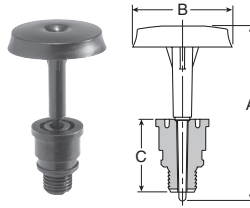

Piston Drain
GRP-96-716



(Use with GRP-95-981 shown above. Order separately)

Manual Override for Auto Float Drains
GRP-96-001

Dimensions Inches (mm)

Accessories	Part Number	Used On	A	B	C
Differential Pressure Indicator	DP8-01-000	F18, F28, M18, M28	2.12 (54)	1.85 (47)	.84 (21)
Automatic Drains, Nitrile	GRP-95-973	F18, M18, B18, F28, M28, B28	2.93 (74.4)	1.47 (37.3)	1.17 (29.7)
Automatic Drains, Fluorocarbon	GRP-95-981				
Manual Override for Auto Float Drains	GRP-96-001	GRP-95-981	—	—	—
Piston Drain	GRP-96-716	F08, M08, B08	1.70 (43)	.94 (24)	.68 (17)

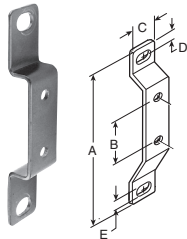

T-Bracket
GPA-96-602

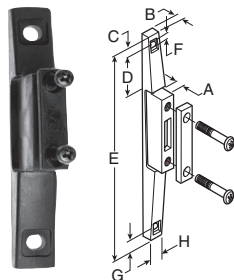

T-Bracket
GPA-96-737
w/ Joinder

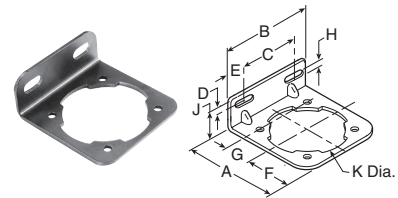

L-Bracket
GPA-96-604, GPA-96-605

Dimensions Inches (mm)

Accessories	Part Number	Used On	A	B	C	D	E	F	G	H	J	K
L-Bracket	GPA-96-604	F18, M18, B18	2.84 (72)	2.74 (69.5)	1.66 (42)	.38 (9.6)	.54 (14)	1.26 (32)	.88 (22)	.28 (7.1)	1.10 (28)	2.25 (57)
	GPA-96-605	F28, M28, B28	3.44 (87)	3.00 (76)	1.88 (48)	.38 (9.6)	.56 (14)	1.49 (38)	1.10 (28)	.28 (7.1)	1.10 (28)	2.66 (67.5)
T-Bracket	GPA-96-602	F18, F28, M18, M28	3.75 (95)	1.25 (32)	.76 (19.3)	.25 (6.3)	.28 (7.1)	—	—	—	—	—
T-Bracket w/ Joinder	GPA-96-737	F08, M08	.45 (11)	.28 (7.1)	.40 (10)	.67 (17)	3.97 (100.8)	.22 (5.6)	.40 (10)	.64 (16)	—	—

Accessories – Regulators

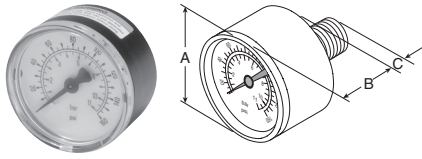

Gauges



Digital Gauge

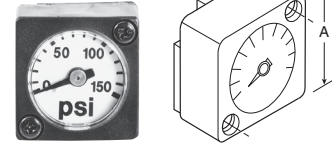

Flush Mount Gauge
08 Series

Dimensions Inches (mm)

Accessories		Used On	A	B	C
Gauges, 5mm 2" Round 1/4" Center Back Mount	K4520N14030 (0 to 30 PSIG)	R18, R28	1.97 (50)	0.94 (24)	0.71 (18)
	K4520N14060 (0 to 60 PSIG)				
	K4520N14160 (0 to 160 PSIG)				
	K4520N14300 (0 to 300 PSIG)				
Gauges, 1/8 Port, CBM	K4515N18060 (0 to 60 PSIG)	R08	1.64 (41.6)	1.09 (27.6)	.80 (20)
	K4515N18160 (0 to 160 PSIG)				
Flush Mount Series Gauges	K4511SCR060 (0 to 60 PSIG)	R08	1.06 (26.9)	.63 (16)	—
	K4511SCR160 (0 to 160 PSIG)	R08			
	K4511SCR11B (0 to 11 bar)	R08			
Round Digital Gauge, 1/4 Port	K4517N14160D (0 to 160 PSIG)	R18, R28	1-3/4" Diameter		

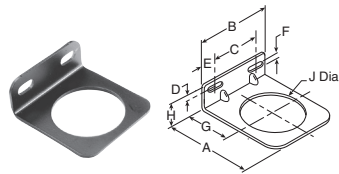

L-Bracket
GPA-96-606, GPA-96-607

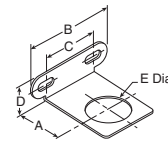

L-Bracket
GRP-96-739

Dimensions Inches (mm)

Accessories		Used On	A	B	C	D	E	F	G	H	J
L-Bracket	GRP-96-739	R08, R09	1.57 (40)	2.68 (68)	1.74 (44)	.97 (25)	1.19 (30)	—	—	—	—
	GPA-96-606	R18, R19	2.74 (69.5)	2.74 (69.5)	1.66 (42)	.43 (11)	.54 (14)	.28 (7.1)	1.57 (40)	1.00 (25)	2.0 (51)
	GPA-96-607	R28	3.33 (84.5)	3.00 (76)	1.88 (48)	.43 (11)	.56 (14)	2.40 (61)	1.94 (49)	1.00 (25)	2.40 (61)

Regulator Replacement Kits

Model	Self-relieving Diaphragm (Nitrile)	Non-relieving Diaphragm (Nitrile)	Plastic Panel Nut	Aluminum Panel Nut
R08, R09	GRP-96-725B	GRP-96-726B	RPA-96-734	RPA-96-733
R18, R19	RRP-96-656B	RRP-96-657B	RRP-96-675B	RRP-96-673
R28	RRP-96-986	RRP-96-987	RRP-96-676	RRP-96-674
Model	Main Regulating Spring 0-30 PSIG	Main Regulating Spring 0-60 PSIG	Main Regulating Spring 0-125 PSIG	Main Regulating Spring 0-250 PSIG
R08, R09	GRP-95-111	GRP-96-718	GRP-96-717	N/A
R18, R19	RRP-96-659	RRP-96-660	RRP-96-661	RRP-96-662
R28	RRP-96-163	RRP-96-164	RRP-96-165	RRP-96-166

Lubricator Replacement Bowl Kits



Model	Manual Drain Kit	Plastic Bowl / Bowl Guard Manual Drain	Metal Bowl / Sight Gauge Manual Drain
L08	—	LRP-96-736	GRP-96-714*
L18	GRP-96-685	LRP-96-701	GRP-96-636
L28	GRP-96-685	LRP-96-702	GRP-96-644

*Metal bowl does not have sight gauge. ** No Drain.

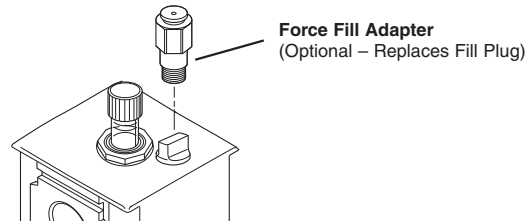

Lubricator Replacement Kits

Model	Siphon Tube Assembly	Bowl O-ring (Nitrile)	Bowl O-ring (Fluorocarbon)	Force Fill Adapter	Fill Plug Kit (Fill Plug & O-ring)	Sight Dome Assembly
L08	LRP-96-731	GRP-96-710	GRP-96-711	N/A	LRP-96-730	LRP-96-301
L18	LRP-96-677	GRP-96-640	GRP-96-754	LRP-96-704	LRP-96-679	LRP-96-720
L28	LRP-96-781	GRP-96-654	GRP-96-755	LRP-96-704	LRP-96-679	LRP-96-720

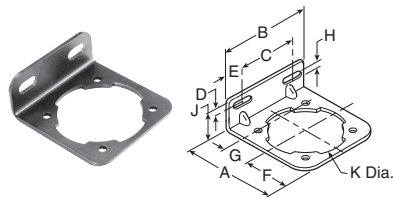

L-Bracket
GPA-96-604, GPA-96-605

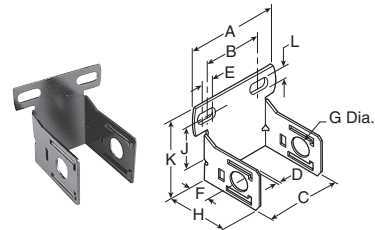

C-Bracket
GPA-97-010

Accessories – Lubricators

Dimensions Inches (mm)

Accessories	Part Number	Used On	A	B	C	D	E	F	G	H	J	K	L
C-Bracket	GPA-97-010	L08	2.67 (68)	1.73 (44)	1.57 (40)	.07 (1.8)	.39 (9.9)	1.57 (40)	.78 (20)	2.32 (59)	1.37 (35)	2.41 (61)	.26 (6.6)
L-Bracket	GPA-96-604	L18	2.84 (72)	2.74 (69.5)	1.66 (42)	.38 (9.6)	.54 (14)	1.26 (32)	.88 (22)	.28 (7.1)	1.10 (28)	2.25 (57)	—
	GPA-96-605	L28	3.44 (87)	3.00 (76)	1.88 (48)	.38 (9.6)	.56 (14)	1.49 (38)	1.10 (28)	.28 (7.1)	1.10 (28)	2.66 (67.5)	—

F442 Oil

- F442001 - 1 Quart Bottle
- F442002 - 1 Gallon
- F442005 - 4 Gallon Case



Filter / Regulators Replacement Repair Kits



Model	Plastic Bowl / Bowl Guard Manual Drain	Metal Bowl / Sight Gauge Manual Drain	Plastic Bowl / Bowl Guard Automatic Drain	Metal Bowl / Sight Gauge Automatic Drain	Plastic Bowl / Bowl Guard Closed Bottom
B08	GRP-96-712	GRP-96-714*	N/A	N/A	N/A
B18	GRP-96-634	GRP-96-636	GRP-96-635	GRP-96-637	GRP-96-638
B28	GRP-96-642	GRP-96-644	GRP-96-643	GRP-96-645	GRP-96-652

* Metal bowl does not have sight gauge.

Model	Filter Element 5 Micron	Bowl O-ring (Nitrile)	Bowl O-ring (Fluorocarbon)	Filter Retainer Element Baffle	Manual Drain
B08	FRP-96-729	GRP-96-710	GRP-96-711	N/A	N/A
B18	FRP-96-639	GRP-96-640	GRP-96-754	FRP-96-641	GRP-96-685
B28	FRP-96-653	GRP-96-654	GRP-96-755	FRP-96-283	GRP-96-685

Model	Self-relieving Diaphragm (Nitrile)	Non-relieving Diaphragm (Nitrile)
B08	GRP-96-725B	GRP-96-726B
B18	RRP-96-656B	RRP-96-657B
B28	RRP-96-986	RRP-96-987

Model	Main Regulating Spring 0-30 PSIG	Main Regulating Spring 0-60 PSIG	Main Regulating Spring 0-125 PSIG	Main Regulating Spring 0-250 PSIG
B08	GRP-95-111B	GRP-96-718B	GRP-96-717B	N/A
B18	RRP-96-659B	RRP-96-660B	RRP-96-661B	RRP-96-662B
B28	RRP-96-163	RRP-96-164	RRP-96-165	RRP-96-166

Tamper Resistant Model	Aluminum Resistant Ring	Plastic Panel Nut	Metal Panel Nut
B08	RPA-95-735	RPA-96-733	RPA-96-734
B18	RRP-96-671	RRP-96-673B	RRP-96-675
B28	RRP-96-672	RRP-96-674	RRP-96-676

Accessories Filter / Regulators

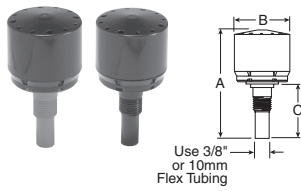

Automatic Drain
GRP-95-973, GRP-95-981

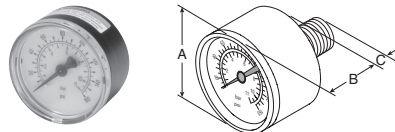

Gauges

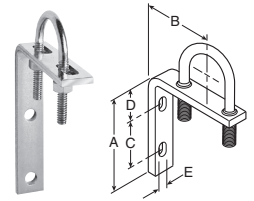

**Wall Mounting Bracket
U-Bolt Pipe Clamp**
GRP-95-734

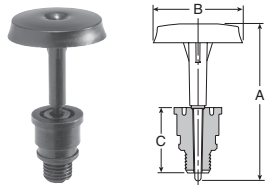

Piston Drain
GRP-96-716



Digital Gauge



Flush Mount Gauge
08 Series

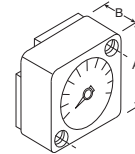

Dimensions Inches (mm)

Accessories	Part Number	Used On	A	B	C	D	E
Automatic Drains, Nitrile	GRP-95-973	B18, B28	2.93 (74.4)	1.47 (37.3)	1.17 (29.7)	—	—
Automatic Drains, Fluorocarbon	GRP-95-981	B18, B28					
Piston Drain	GRP-96-716	B08	1.70 (43)	.94 (24)	.68 (17)	—	—
Gauges, 5mm 2" Round 1/4" Center Back Mount	K4520N14030 (0 to 30 PSIG)	B18, B28	1.97 (50)	0.94 (24)	0.71 (18)	—	—
	K4520N14060 (0 to 60 PSIG)						
	K4520N14160 (0 to 160 PSIG)						
	K4520N14300 (0 to 300 PSIG)						
Flush Mount Series Gauges	K4511SCR150 (0 to 150 PSIG)	B08	1.06 (26.9)	.63 (16)	—	—	—
	K4511SCR060 (0 to 60 PSIG)						
	K4511SCR11B (0 to 11 bar)						
Round Digital Gauge, 1/4 Port	K4517N14160D (0 to 160 PSIG)	B18, B28	1-3/4" Diameter				
Wall Mtg. Bracket U-Bolt Pipe Clamp	GRP-95-734	For All Non-Modular Units Up to 1" NPT	3.34 (85)	2.76 (70)	1.62 (41)	1.10 (28)	0.30 (7.6)

Accessories – Filter / Regulators

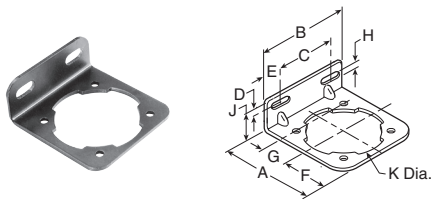

Body L-Bracket
GPA-96-604

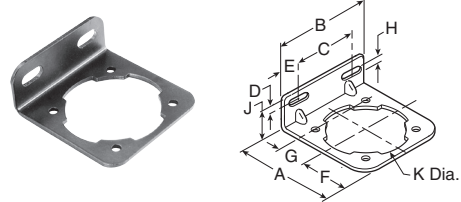

Body L-Bracket
GPA-96-605

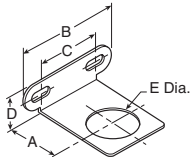

L-Bracket
GRP-96-739

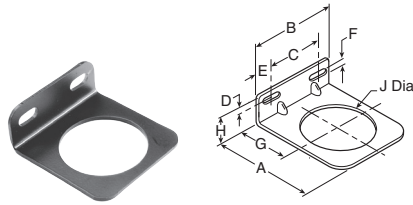

Bonnet L-Bracket
GPA-96-606

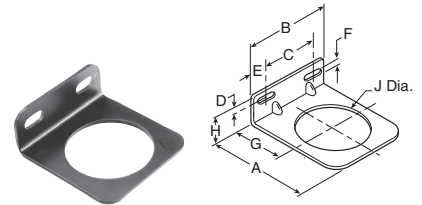

Bonnet L-Bracket
GPA-96-607

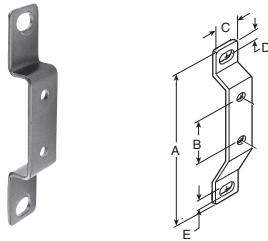

T-Bracket
GPA-96-602

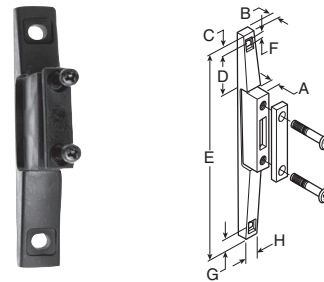

T-Bracket
GPA-96-737
w/ Joiner

Dimensions Inches (mm)

Accessories	Part Number	Used On	A	B	C	D	E	F	G	H	J	K	L
L-Bracket (Bonnet)	GPA-96-606	B18	2.74 (69.5)	2.74 (69.5)	1.66 (42)	.43 (11)	.54 (14)	.28 (7.1)	1.57 (40)	1.00 (25)	2.0 (51)	—	—
	GPA-96-607	B28	3.33 (84.5)	3.00 (76)	1.88 (48)	.43 (11)	.56 (14)	2.40 (61)	1.94 (49)	1.00 (25)	2.40 (61)	—	—
	GRP-96-739	B08	1.57 (40)	2.68 (68)	1.74 (44)	.97 (25)	1.19 (30)	—	—	—	—	—	—
L-Bracket (Body)	GPA-96-604	B18	2.84 (72)	2.74 (69.5)	1.66 (42)	.38 (9.6)	.54 (14)	1.26 (32)	.88 (22)	.28 (7.1)	1.10 (28)	2.25 (57)	—
	GPA-96-605	B28	3.44 (87)	3.00 (76)	1.88 (48)	.38 (9.6)	.56 (14)	1.49 (38)	1.10 (28)	.28 (7.1)	1.10 (28)	2.66 (67.5)	—
	GPA-97-010	B08	2.67 (68)	1.73 (44)	1.57 (40)	.07 (1.8)	.39 (9.9)	1.57 (40)	.78 (20)	2.32 (59)	1.37 (35)	2.41 (61)	.26 (6.6)
T-Bracket	GPA-96-602	B18, B28	3.75 (95)	1.00 (25.4)	.76 (19.3)	.25 (6.3)	.28 (7.1)	—	—	—	—	—	—
T-Bracket w/ Joiner	GPA-96-737	B08	.45 (11)	.28 (7.1)	.40 (10)	.67 (17)	3.97 (100.8)	.22 (5.6)	.40 (10)	.64 (16)	—	—	—

Modular Accessories – 08 Series

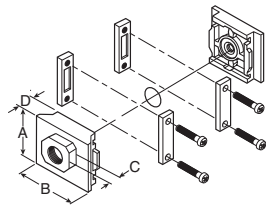

End Block Set



End Block Set w/ T-Bracket

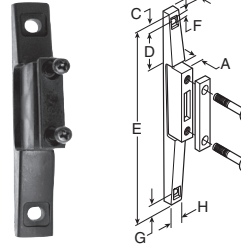

T-Bracket GPA-96-737 w/ Joiner

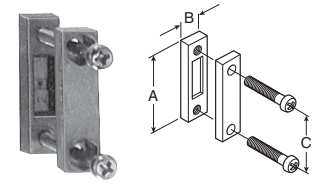

Joiner Set GPA-96-738 (O-ring not shown)

Dimensions Inches (mm)

Accessories	Part Number	Pipe Size	A	B	C	D	E	F	G	H
T-Bracket Joiner Set	GPA-96-737	—	.45 (11)	.28 (7.1)	.40 (10)	.67 (17)	3.97 (100.8)	.22 (5.6)	.40 (10)	.64 (16)
Joiner Set	GPA-96-738	—	1.42 (36)	.39 (9.9)	.98 (26)	—	—	—	—	—
End Block Set	GPA-97-018	1/8 NPT	1.42 (36)	1.57 (40)	.53 (13.5)	.31 (8)	—	—	—	—
	GPA-97-019	1/4 NPT								
	GPA-97-020	3/8 NPT								
	GPA-97-066	G 1/8								
	GPA-97-067	G 1/4								
End Block Set With T-Brackets	GPA-97-025	1/8 NPT	1.42 (36)	1.57 (40)	.53 (13.5)	.31 (8)	—	—	—	—
	GPA-97-026	1/4 NPT								
	GPA-97-027	3/8 NPT								
	GPA-97-068	G 1/8								
	GPA-97-069	G 1/4								
GPA-97-070	G 3/8									

Modular Accessories – 18 / 28 Series

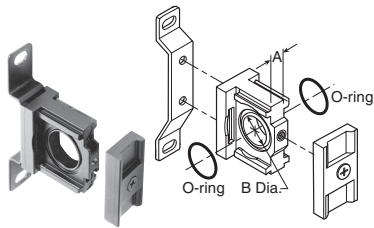

T-Bracket w/ Joiner Set GPA-96-603

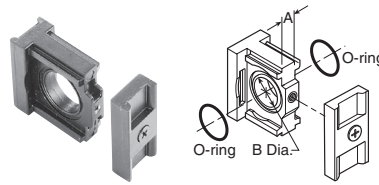

Joiner Set GPA-96-601

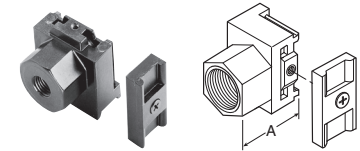

End Block

Dimensions Inches (mm)

Accessories	Part Number	Pipe Size	A	B
T-Bracket w/ Joiner Set	GPA-96-603	—	.35 (8.9)	.87 (22.1)
Joiner Set	GPA-96-601	—	.35 (8.9)	.87 (22.1)
End Block	GPA-96-610	1/4 NPT	1.59 (40)	—
	GPA-96-611	3/8 NPT		
	GPA-96-612	1/2 NPT		
	GPA-96-613	3/4 NPT		
	GPA-96-620	G 1/4		
	GPA-96-621	G 3/8		
	GPA-96-622	G 1/2		
GPA-96-623	G 3/4			

Safety Guide For Selecting And Using Pneumatic Division Products And Related Accessories



WARNING:

FAILURE OR IMPROPER SELECTION OR IMPROPER USE OF PNEUMATIC DIVISION PRODUCTS, ASSEMBLIES OR RELATED ITEMS (“PRODUCTS”) CAN CAUSE DEATH, PERSONAL INJURY, AND PROPERTY DAMAGE. POSSIBLE CONSEQUENCES OF FAILURE OR IMPROPER SELECTION OR IMPROPER USE OF THESE PRODUCTS INCLUDE BUT ARE NOT LIMITED TO:

- Unintended or mistimed cycling or motion of machine members or failure to cycle
- Work pieces or component parts being thrown off at high speeds.
- Failure of a device to function properly for example, failure to clamp or unclamp an associated item or device.
- Explosion
- Suddenly moving or falling objects.
- Release of toxic or otherwise injurious liquids or gasses.

Before selecting or using any of these Products, it is important that you read and follow the instructions below.

1. GENERAL INSTRUCTIONS

- 1.1. Scope:** This safety guide is designed to cover general guidelines on the installation, use, and maintenance of Pneumatic Division Valves, FRLs (Filters pressure Regulators and Lubricators), Vacuum products and related accessory components.
- 1.2. Fail-Safe:** Valves, FRLs, Vacuum products and their related components can and do fail without warning for many reasons. Design all systems and equipment in a fail-safe mode, so that failure of associated valves, FRLs or Vacuum products will not endanger persons or property.
- 1.3 Relevant International Standards:** For a good guide to the application of a broad spectrum of pneumatic fluid power devices see: ISO 4414:1998, Pneumatic Fluid Power – General Rules Relating to Systems. See www.iso.org for ordering information.
- 1.4. Distribution:** Provide a copy of this safety guide to each person that is responsible for selection, installation, or use of Valves, FRLs or Vacuum products. Do not select, or use Wilkerson valves, FRLs or vacuum products without thoroughly reading and understanding this safety guide as well as the specific Wilkerson publications for the products considered or selected.
- 1.5. User Responsibility:** Due to the wide variety of operating conditions and applications for valves, FRLs, and vacuum products Wilkerson and its distributors do not represent or warrant that any particular valve, FRL or vacuum product is suitable for any specific end use system. This safety guide does not analyze all technical parameters that must be considered in selecting a product. The user, through its own analysis and testing, is solely responsible for:
 - Making the final selection of the appropriate valve, FRL, Vacuum component, or accessory.
 - Assuring that all user's performance, endurance, maintenance, safety, and warning requirements are met and that the application presents no health or safety hazards.
 - Complying with all existing warning labels and / or providing all appropriate health and safety warnings on the equipment on which the valves, FRLs or Vacuum products are used; and,
 - Assuring compliance with all applicable government and industry standards.
- 1.6. Safety Devices:** Safety devices should not be removed, or defeated.
- 1.7. Warning Labels:** Warning labels should not be removed, painted over or otherwise obscured.
- 1.8. Additional Questions:** Call the appropriate Wilkerson technical service department if you have any questions or require any additional information. See the Wilkerson publication for the product being considered or used, or call 269-629-2550, or go to www.wilkersoncorp.com, for telephone numbers of the appropriate technical service department.

2. PRODUCT SELECTION INSTRUCTIONS

- 2.1. Flow Rate:** The flow rate requirements of a system are frequently the primary consideration when designing any pneumatic system. System components need to be able to provide adequate flow and pressure for the desired application.
- 2.2. Pressure Rating:** Never exceed the rated pressure of a product. Consult product labeling, Pneumatic Division catalogs or the instruction sheets supplied for maximum pressure ratings.
- 2.3. Temperature Rating:** Never exceed the temperature rating of a product. Excessive heat can shorten the life expectancy of a product and result in complete product failure.
- 2.4. Environment:** Many environmental conditions can affect the integrity and suitability of a product for a given application. Pneumatic Division products are designed for use in general purpose industrial applications. If these products are to be used in unusual circumstances such as direct sunlight and/or corrosive or caustic environments, such use can shorten the useful life and lead to premature failure of a product.
- 2.5. Lubrication and Compressor Carryover:** Some modern synthetic oils can and will attack nitrile seals. If there is any possibility of synthetic oils or greases migrating into the pneumatic components check for compatibility with the seal materials used. Consult the factory or product literature for materials of construction.
- 2.6. Polycarbonate Bowls and Sight Glasses:** To avoid potential polycarbonate bowl failures:
 - Do not locate polycarbonate bowls or sight glasses in areas where they could be subject to direct sunlight, impact blow, or temperatures outside of the rated range.
 - Do not expose or clean polycarbonate bowls with detergents, chlorinated hydro-carbons, ketones, esters or certain alcohols.
 - Do not use polycarbonate bowls or sight glasses in air systems where compressors are lubricated with fire resistant fluids such as phosphate ester and di-ester lubricants.

2.7. Chemical Compatibility: For more information on plastic component chemical compatibility see Pneumatic Division technical bulletins Tec-3, Tec-4, and Tec-5

- 2.8. Product Rupture:** Product rupture can cause death, serious personal injury, and property damage.
- Do not connect pressure regulators or other Pneumatic Division products to bottled gas cylinders.
 - Do not exceed the maximum primary pressure rating of any pressure regulator or any system component.
 - Consult product labeling or product literature for pressure rating limitations.

3. PRODUCT ASSEMBLY AND INSTALLATION INSTRUCTIONS

3.1. Component Inspection: Prior to assembly or installation a careful examination of the valves, FRLs or vacuum products must be performed. All components must be checked for correct style, size, and catalog number. DO NOT use any component that displays any signs of nonconformance.

3.2. Installation Instructions: Wilkerson published Installation Instructions must be followed for installation of Wilkerson valves, FRLs and vacuum components. These instructions are provided with every Wilkerson valve or FRL sold, or by calling 269-629-2550, or at www.wilkersoncorp.com.

3.3. Air Supply: The air supply or control medium supplied to Valves, FRLs and Vacuum components must be moisture-free if ambient temperature can drop below freezing

4. VALVE AND FRL MAINTENANCE AND REPLACEMENT INSTRUCTIONS

4.1. Maintenance: Even with proper selection and installation, valve, FRL and vacuum products service life may be significantly reduced without a continuing maintenance program. The severity of the application, risk potential from a component failure, and experience with any known failures in the application or in similar applications should determine the frequency of inspections and the servicing or replacement of Pneumatic Division products so that products are replaced before any failure occurs. A maintenance program must be established and followed by the user and, at minimum, must include instructions 4.2 through 4.9.

4.2. Installation and Service Instructions: Before attempting to service or replace any worn or damaged parts consult the appropriate Service Bulletin for the valve or FRL in question for the appropriate practices to service the unit in question. These Service and Installation Instructions are provided with every Wilkerson valve and FRL sold, or are available by calling 269-629-2550, or by accessing the Wilkerson web site at www.wilkersoncorp.com.

4.3. Lockout / Tagout Procedures: Be sure to follow all required lockout and tagout procedures when servicing equipment. For more information see: OSHA Standard – 29 CFR, Part 1910.147, Appendix A, The Control of Hazardous Energy – (Lockout / Tagout)

4.4. Visual Inspection: Any of the following conditions requires immediate system shut down and replacement of worn or damaged components:

- Air leakage: Look and listen to see if there are any signs of visual damage to any of the components in the system. Leakage is an indication of worn or damaged components.
- Damaged or degraded components: Look to see if there are any visible signs of wear or component degradation.
- Kinked, crushed, or damaged hoses. Kinked hoses can result in restricted air flow and lead to unpredictable system behavior.
- Any observed improper system or component function: Immediately shut down the system and correct malfunction.
- Excessive dirt build-up: Dirt and clutter can mask potentially hazardous situations.

Caution: Leak detection solutions should be rinsed off after use.

4.5. Routine Maintenance Issues:

- Remove excessive dirt, grime and clutter from work areas.
- Make sure all required guards and shields are in place.

4.6. Functional Test: Before initiating automatic operation, operate the system manually to make sure all required functions operate properly and safely.

4.7. Service or Replacement Intervals: It is the user's responsibility to establish appropriate service intervals. Valves, FRLs and vacuum products contain components that age, harden, wear, and otherwise deteriorate over time. Environmental conditions can significantly accelerate this process. Valves, FRLs and vacuum components need to be serviced or replaced on routine intervals. Service intervals need to be established based on:

- Previous performance experiences.
- Government and / or industrial standards.
- When failures could result in unacceptable down time, equipment damage or personal injury risk.

4.8. Servicing or Replacing of any Worn or Damaged Parts: To avoid unpredictable system behavior that can cause death, personal injury and property damage:

- Follow all government, state and local safety and servicing practices prior to service including but not limited to all OSHA Lockout Tagout procedures (OSHA Standard – 29 CFR, Part 1910.147, Appendix A, The Control of Hazardous Energy – Lockout / Tagout).
- Disconnect electrical supply (when necessary) before installation, servicing, or conversion.
- Disconnect air supply and depressurize all air lines connected to system and Pneumatic Division products before installation, service, or conversion.
- Installation, servicing, and / or conversion of these products must be performed by knowledgeable personnel who understand how pneumatic products are to be applied.
- After installation, servicing, or conversions air and electrical supplies (when necessary) should be connected and the product tested for proper function and leakage. If audible leakage is present, or if the product does not operate properly, do not put product or system into use.
- Warnings and specifications on the product should not be covered or painted over. If masking is not possible, contact your local representative for replacement labels.

4.9. Putting Serviced System Back into Operation: Follow the guidelines above and all relevant Installation and Maintenance Instructions supplied with the valve FRL or vacuum component to insure proper function of the system.

Warning: Use Limitations

Wilkerson's warranties are void, and Wilkerson assumes no responsibility for any resulting cost, loss, injury or any other damages whatsoever, with respect to any plastic bowl unit for which a bowl guard is standard equipment if the unit is placed in service without the bowl guard and, except as otherwise specified in writing by Wilkerson, with respect to any Wilkerson products which are used in other than compressed air service. Specific warnings with respect to these and other use limitations appear elsewhere in this catalog.

Wilkerson maintains a policy of ongoing product development and improvement. We therefore reserve the right to change dimensions specification and design without notice.

Do not place plastic bowl unit in service without bowl guard installed.

Plastic bowl units are sold only with bowl guards with the exception to miniature units (C04). To minimize the danger of flying fragments in the event of plastic bowl failure, the bowl guards should not be removed. If the unit is in service without the bowl guard installed, manufacturer's warranties are void, and the manufacturer assumes no responsibility for any resulting loss.

If the unit has been in service and does not have a bowl guard, order one and install before placing back in service.

Caution

Certain compressor oils, chemicals, household cleaners, solvents, paints and fumes will attack plastic bowls and can cause bowl failure. Do not use near these materials. When bowl becomes dirty replace bowl or wipe only with a clean, dry cloth. Reinstall bowl guard or buy and install a bowl guard. Immediately replace any crazed, cracked, damaged or deteriorated plastic bowl with a bowl or a new plastic bowl and bowl guard.

Caution

Except as otherwise specified by the manufacturer, this product is specifically designed for compressed air service, and use with any other fluid (liquid or gas) is a misapplication. For example, use with or injection of certain hazardous liquids or gases in the system (such as alcohol or liquid petroleum gas) could be harmful to the unit or result in a combustible condition or hazardous external leakage. Before using with fluids other than air, or for non-industrial applications, or for life support systems, consult Wilkerson Operations for written approval.

Some of the Materials that will Attack Polycarbonate Plastic Bowls

Acetaldehyde	Chloroform	Milk of Lime (CaOH)
Acetic acid (conc.)	Cresol	Nitric Acid (conc.)
Acetone	Cyclohexanol	Nitrobenzene
Acrylonitrile	Cyclohexanone	Nitrocellulose Lacquer
Ammonia	Cyclohexene	Phenol
Ammonium Fluoride	Dimethyl Formamide	Phosphorous Hydroxy Chloride
Ammonium Hydroxide	Diozane	Perchloroethylene
Ammonium Sulfide	Ethgane tetrachloride	Phosphorous
Anaerobic adhesives	Ethyl Acetate	Propionic Acid
Trichloride and Sealants	Ethyl Ether	Pyridine
Antifreeze	Ethylamine	Sodium Hydroxide
Benzene	Ethylene Chlorohydrin	Sodium Sulfide
Benzoic Acid	Ethylene Dichloride	Styrene
Benzyl Alcohol	Ethylene Glycol	Sulfuric Acid (conc.)
Brake Fluids	Formic Acid (conc.)	Sulphural Chloride
Bromobenzene	Freon (Refrig. & Propell.)	Tetrahydronaphthalene
Butyric Acid	Gasoline (High Aromatic)	Tiophene
Carbolic Acid	Hydrazine	Toluene
Carbon Disulfide	Hydrochloric Acid (conc.)	Turpentine
Carbon Tetrachloride	Lacquer Thinner	Xylene & Others
Caustic Potash Solution	Methyl Alcohol	
Caustic Soda Solution	Methylene Chloride	
Chlorobenzene	Methylene Salicylate	

Trade Names of some Compressor Oils, Rubber Compounds and other Materials that will Attack Polycarbonate Plastic Bowls.

Atlas "Perma-Guard"	National Compound #N11
Buna N	"Nylock" VC-3
Cellulube #150 and #220	Parco #1306 Neoprene
Crylex #5 cement	*Permabond 910
*Eastman 910	Petron PD287
Garlock #98403 (polyurethane)	Prestone
Haskel #568-023	Pydraul AC
Hilgard Co.'s hil phene	Sears Regular Motor Oil
Houghton & Co. oil #1120, #1130 & #1055	Sinclair oil "Lily White"
Houtosafe 1000	Stauffer Chemical FYRQUEL #150
Kano Kroil	Stillman #SR 269-75 (polyurethane)
Keystone penetrating oil #2	Stillman #SR 513-70 (neoprene)
*Loctite 271	Tannergas
*Locite 290	Telar
*Loctite 601	Tenneco anderol #495 & #500 oils
*Loctite Teflon-Sealant	Titon
Marvel Mystery Oil	*Vibra-tite
Minn. Rubber 366Y	Zerex
*When in raw liquid form.	

We cannot possibly list all harmful substances, so check with Mobay or the General Electric office for further information on polycarbonate plastic.

The trade names "EconOmist" and "Flow-Guide" are registered at the United States Patent Office.

"Auto-Fill", "Dial-Air", "Flex-Drain", "Mainliner" and "Whirl-Flo" are tradenames of Wilkerson.

Claims and Shortages: Risk of loss passes to buyer when goods are delivered to the carrier. Inspect all shipments for damage at time of receipt. Claims should be filed by the consignee against the carrier.

Changes: Wilkerson maintains a policy of ongoing product development and improvement. We therefore reserve the right to change dimensions, specifications and design without notice.

PARKER-HANNIFIN CORPORATION
OFFER OF SALE

1. **Definitions.** As used herein, the following terms have the meanings indicated.

Buyer:	means any customer receiving a Quote for Products from Seller.
Goods:	means any tangible part, system or component to be supplied by the Seller.
Products:	means the Goods, Services and/or Software as described in a Quote provided by the Seller.
Quote:	means the offer or proposal made by Seller to Buyer for the supply of Products.
Seller:	means Parker-Hannifin Corporation, including all divisions and businesses thereof.
Services:	means any services to be supplied by the Seller.
Software:	means any software related to the Products, whether embedded or separately downloaded.
Terms:	means the terms and conditions of this Offer of Sale or any newer version of the same as published by Seller electronically at www.parker.com/saleterms .

2. **Terms.** All sales of Products by Seller are contingent upon, and will be governed by, these Terms and, these Terms are incorporated into any Quote provided by Seller to any Buyer. Buyer's order for any Products whether communicated to Seller verbally, in writing, by electronic data interface or other electronic commerce, shall constitute acceptance of these Terms. Seller objects to any contrary or additional terms or conditions of Buyer. Reference in Seller's order acknowledgement to Buyer's purchase order or purchase order number shall in no way constitute an acceptance of any of Buyer's terms of purchase. No modification to these Terms will be binding on Seller unless agreed to in writing and signed by an authorized representative of Seller.

3. **Price; Payment.** The Products set forth in Seller's Quote are offered for sale at the prices indicated in Seller's Quote. Unless otherwise specifically stated in Seller's Quote, prices are valid for thirty (30) days and do not include any sales, use, or other taxes or duties. Seller reserves the right to modify prices at any time to adjust for any raw material price fluctuations. Unless otherwise specified by Seller, all prices are F.C.A. Seller's facility (INCOTERMS 2010). All sales are contingent upon credit approval and payment for all purchases is due thirty (30) days from the date of invoice (or such date as may be specified in the Quote). Unpaid invoices beyond the specified payment date incur interest at the rate of 1.5% per month or the maximum allowable rate under applicable law.

4. **Shipment; Delivery; Title and Risk of Loss.** All delivery dates are approximate. Seller is not responsible for damages resulting from any delay. Regardless of the manner of shipment, delivery occurs and title and risk of loss or damage pass to Buyer, upon placement of the Products with the shipment carrier at Seller's facility. Unless otherwise agreed, Seller may exercise its judgment in choosing the carrier and means of delivery. No deferment of shipment at Buyer's request beyond the respective indicated shipping date will be made except on terms that will indemnify, defend and hold Seller harmless against all loss and additional expense. Buyer shall be responsible for any additional shipping charges incurred by Seller due to Buyer's acts or omissions.

5. **Warranty.** The warranty related to the Products is as follows: (i) Goods are warranted against defects in material or workmanship for a period of twelve (12) months from the date of delivery or 2,000 hours of use, whichever occurs first; (ii) Services shall be performed in accordance with generally accepted practices and using the degree of care and skill that is ordinarily exercised and customary in the field to which the Services pertain and are warranted for a period of six (6) months from the completion of the Services by Seller; and (iii) Software is only warranted to perform in accordance with applicable specifications provided by Seller to Buyer for ninety (90) days from the date of delivery or, when downloaded by a Buyer or end-user, from the date of the initial download. All prices are based upon the exclusive limited warranty stated above, and upon the following disclaimer:

DISCLAIMER OF WARRANTY: THIS WARRANTY IS THE SOLE AND ENTIRE WARRANTY PERTAINING TO PRODUCTS. SELLER DISCLAIMS ALL OTHER WARRANTIES, EXPRESS AND IMPLIED, INCLUDING DESIGN, NONINFRINGEMENT, MERCHANTABILITY, AND FITNESS FOR A PARTICULAR PURPOSE. SELLER DOES NOT WARRANT THAT THE SOFTWARE IS ERROR-FREE OR FAULT-TOLERANT, OR THAT BUYER'S USE THEREOF WILL BE SECURE OR UNINTERRUPTED. BUYER AGREES AND ACKNOWLEDGES THAT UNLESS OTHERWISE AUTHORIZED IN WRITING BY SELLER THE SOFTWARE SHALL NOT BE USED IN CONNECTION WITH HAZARDOUS OR HIGH RISK ACTIVITIES OR ENVIRONMENTS. EXCEPT AS EXPRESSLY STATED HEREIN, ALL PRODUCTS ARE PROVIDED "AS IS".

6. **Claims; Commencement of Actions.** Buyer shall promptly inspect all Products upon receipt. No claims for shortages will be allowed unless reported to the Seller within ten (10) days of delivery. Buyer shall notify Seller of any alleged breach of warranty within thirty (30) days after the date the non-conformance is or should have been discovered by Buyer. Any claim or action against Seller based upon breach of contract or any other theory, including tort, negligence, or otherwise must be commenced within twelve (12) months from the date of the alleged breach or other alleged event, without regard to the date of discovery.

7. **LIMITATION OF LIABILITY.** IN THE EVENT OF A BREACH OF WARRANTY, SELLER WILL, AT ITS OPTION, REPAIR OR REPLACE THE NON-CONFORMING PRODUCT, RE-PERFORM THE SERVICES, OR REFUND THE PURCHASE PRICE PAID WITHIN A REASONABLE PERIOD OF TIME. IN NO EVENT IS SELLER LIABLE FOR ANY SPECIAL, INDIRECT, INCIDENTAL OR CONSEQUENTIAL DAMAGES ARISING OUT OF, OR AS THE RESULT OF, THE SALE, DELIVERY, NON-DELIVERY, SERVICING, NON-COMPLETION OF SERVICES, USE, LOSS OF USE OF, OR INABILITY TO USE THE PRODUCTS OR ANY PART THEREOF, LOSS OF DATA, IDENTITY, PRIVACY, OR CONFIDENTIALITY, OR FOR ANY CHARGES OR EXPENSES OF ANY NATURE INCURRED WITHOUT SELLER'S WRITTEN CONSENT, WHETHER BASED IN CONTRACT, TORT OR OTHER LEGAL THEORY. IN NO EVENT SHALL SELLER'S LIABILITY UNDER ANY CLAIM MADE BY BUYER EXCEED THE PURCHASE PRICE PAID FOR THE PRODUCTS.

8. **Loss to Buyer's Property.** Any designs, tools, patterns, materials, drawings, confidential information or equipment furnished by Buyer or any other items which are or become Buyer's property, will be considered obsolete and may be destroyed by Seller after two (2) consecutive years have elapsed without Buyer ordering the Products manufactured using such property. Seller shall not be responsible for any loss or damage to such property while it is in Seller's possession or control.

9. **Special Tooling.** Special Tooling includes but is not limited to tooling, jigs, fixtures and associated manufacturing equipment acquired or necessary to manufacture Products. A tooling charge may be imposed for any Special Tooling. Such Special Tooling shall be and remain Seller's property notwithstanding payment of any charges by Buyer. In no event will Buyer acquire any interest in Special Tooling belonging to Seller that is utilized in the manufacture of the Products, even if such Special Tooling has been specially converted or adapted for such manufacture and notwithstanding any charges paid by Buyer. Unless otherwise agreed, Seller has the right to alter, discard or otherwise dispose of any Special Tooling or other property in its sole discretion at any time.

10. **Security Interest.** To secure payment of all sums due, Seller retains a security interest in all Products delivered to Buyer and, Buyer's acceptance of these Terms is deemed to be a Security Agreement under the Uniform Commercial Code. Buyer authorizes Seller as its attorney to execute and file on Buyer's behalf all documents Seller deems necessary to perfect its security interest.

11. **User Responsibility.** The Buyer through its own analysis and testing, is solely responsible for making the final selection of the Products and assuring that all performance, endurance, maintenance, safety and warning requirements of the application of the Products are met. The Buyer must analyze all aspects of the application and follow applicable industry standards, specifications, and other technical information provided with the Product. If Seller provides Product options based upon data or specifications provided by the Buyer, the Buyer is responsible for determining that such data and specifications are suitable and sufficient for all applications and reasonably foreseeable uses of the Products. In the event the Buyer is not the end-user, Buyer will ensure such end-user complies with this paragraph.

12. **Use of Products, Indemnity by Buyer.** Buyer shall comply with all instructions, guides and specifications provided by Seller with the Products. **Unauthorized Uses.** If Buyer uses or resells the Products for any uses prohibited in Seller's instructions, guides or specifications, or Buyer otherwise fails to comply with Seller's instructions, guides and specifications, Buyer acknowledges that any such use, resale, or non-compliance is at Buyer's sole risk. Buyer shall indemnify, defend, and hold Seller harmless from any losses, claims, liabilities, damages, lawsuits, judgments and costs (including attorney fees and defense costs), whether for personal injury, property damage, intellectual property infringement or any other claim, brought by or incurred by Buyer, Buyer's employees, or any other person, arising out of: (a) improper selection, application, design, specification or other misuse of Products provided by Seller; (b) any act or omission, negligent or otherwise, of Buyer; (c) Seller's use of patterns, tooling, equipment, plans, drawings, designs or specifications or other information or things furnished by Buyer; (d) damage to the Products from an external cause, repair or attempted repair by anyone other than Seller, failure to follow instructions, guides and specifications provided by Seller, use with goods not provided by Seller, or opening, modifying, deconstructing or tampering with the Products for any reason; or (e) Buyer's failure to comply with these Terms. Seller shall not indemnify Buyer under any circumstance except as otherwise provided in these Terms.

13. **Cancellations and Changes.** Buyer may not cancel or modify any order for any reason, except with Seller's written consent and upon terms that will indemnify, defend and hold Seller harmless against all direct, incidental and consequential loss or damage. Seller, at any time, may change Product features, specifications, designs and availability.

14. **Limitation on Assignment.** Buyer may not assign its rights or obligations without the prior written consent of Seller.

15. **Force Majeure.** Seller does not assume the risk and is not liable for delay or failure to perform any of Seller's obligations by reason of events or circumstances beyond its reasonable control ("Events of Force Majeure"). Events of Force Majeure shall include without limitation: accidents, strikes or labor disputes, acts of any government or government agency, acts of nature, delays or failures in delivery from carriers or suppliers, shortages of materials, or any other cause beyond Seller's reasonable control.

16. **Waiver and Severability.** Failure to enforce any provision of these Terms will not invalidate that provision; nor will any such failure prejudice Seller's right to enforce that provision in the future. Invalidation of any provision of these Terms by legislation or other rule of law shall not invalidate any other provision herein and, the remaining provisions will remain in full force and effect.

17. **Termination.** Seller may terminate any agreement governed by or arising from these Terms for any reason and at any time by giving Buyer thirty (30) days prior written notice. Seller may immediately terminate, in writing, if Buyer: (a) breaches any provision of these Terms (b) appoints a trustee, receiver or custodian for all or any part of Buyer's property (c) files a petition for relief in bankruptcy on its own behalf, or one if filed by a third party (d) makes an assignment for the benefit of creditors; or (e) dissolves its business or liquidates all or a majority of its assets.

18. **Ownership of Software.** Seller retains ownership of all Software supplied to Buyer hereunder. In no event shall Buyer obtain any greater right in and to the Software than a right in the nature of a license limited to the use thereof and subject to compliance with any other terms provided with the Software.

19. **Indemnity for Infringement of Intellectual Property Rights.** Seller is not liable for infringement of any patents, trademarks, copyrights, trade dress, trade secrets or similar rights ("Intellectual Property Rights") except as provided in this Section. Seller will defend at its expense and will pay the cost of any settlement or damages awarded in an action brought against Buyer based on a third party claim that one or more of the Products sold hereunder infringes the Intellectual Property Rights of a third party in the country of delivery of the Products by the Seller to the Buyer. Seller's obligation to defend and indemnify Buyer is contingent on Buyer notifying Seller within ten (10) days after Buyer becomes aware of any such claim, and Seller having sole control over the defense of the claim including all negotiations for settlement or compromise. If one or more Products sold hereunder is subject to such a claim, Seller may, at its sole expense and option, procure for Buyer the right to continue using the Products, replace or modify the Products so as to render them non-infringing, or offer to accept return of the Products and refund the purchase price less a reasonable allowance for depreciation. Seller has no obligation or liability for any claim of infringement: (i) arising from information provided by Buyer; or (ii) directed to any Products provided hereunder for which the designs are specified in whole or part by Buyer; or (iii) resulting from the modification, combination or use in a system of any Products provided hereunder. The foregoing provisions of this Section constitute Seller's sole and exclusive liability and Buyer's sole and exclusive remedy for such claims of infringement of Intellectual Property Rights.

20. **Governing Law.** These Terms and the sale and delivery of all Products are deemed to have taken place in, and shall be governed and construed in accordance with, the laws of the State of Ohio, as applicable to contracts executed and wholly performed therein and without regard to conflicts of laws principles. Buyer irrevocably agrees and consents to the exclusive jurisdiction and venue of the courts of Cuyahoga County, Ohio with respect to any dispute, controversy or claim arising out of or relating to the sale and delivery of the Products.

21. **Entire Agreement.** These Terms, along with the terms set forth in the main body of any Quote, forms the entire agreement between the Buyer and Seller and constitutes the final, complete and exclusive expression of the terms of sale. In the event of a conflict between any term set forth in the main body of a Quote and these Terms, the terms set forth in the main body of the Quote shall prevail. All prior or contemporaneous written or oral agreements or negotiations with respect to the subject matter shall have no effect. These Terms may not be modified unless in writing and signed by an authorized representative of Seller.

22. **Compliance with Laws.** Buyer agrees to comply with all applicable laws, regulations, and industry and professional standards, including those of the United States of America, and the country or countries in which Buyer may operate, including without limitation the U.S. Foreign Corrupt Practices Act ("FCPA"), the U.S. Anti-Kickback Act ("Anti-Kickback Act"), U.S. and E.U. export control and sanctions laws ("Export Laws"), the U.S. Food Drug and Cosmetic Act ("FDCA"), and the rules and regulations promulgated by the U.S. Food and Drug Administration ("FDA"), each as currently amended. Buyer agrees to indemnify, defend, and hold harmless Seller from the consequences of any violation of such laws, regulations and standards by Buyer, its employees or agents. Buyer acknowledges that it is familiar with all applicable provisions of the FCPA, the Anti-Kickback Act, Export Laws, the FDCA and the FDA and certifies that Buyer will adhere to the requirements thereof and not take any action that would make Seller violate such requirements. Buyer represents and agrees that Buyer will not make any payment or give anything of value, directly or indirectly, to any governmental official, foreign political party or official thereof, candidate for foreign political office, or commercial entity or person, for any improper purpose, including the purpose of influencing such person to purchase Products or otherwise benefit the business of Seller. Buyer further represents and agrees that it will not receive, use, service, transfer or ship any Product from Seller in a manner or for a purpose that violates Export Laws or would cause Seller to be in violation of Export Laws.

WILKERSON®

Pneumatic Division
8676 E. M89
P.O. Box 901
Richland, MI 49083 USA

Applications Engineering

Phone: 877-321-4736 Option #2
E-mail: pdnapps@parker.com

Customer Support

Phone: 877-321-4736 Option #1
E-mail: wilkerson_sales@parker.com