

Pneumatic Division

Richland, Michigan USA

www.parker.com/pneumatics**B VALVE SERIES**

Bulletin Number	Bulletin Description
<input type="checkbox"/> V339P	B2 Manifold Isolator Plug, Installation Instructions
<input type="checkbox"/> V355P	B4...A 3 & 4-Way Inline Valve, Installation & Operation Instructions
<input type="checkbox"/> V356P	B4 Installation & Service Instructions
<input type="checkbox"/> V357P	B4 Modular Manifold, Assembly Procedure
<input type="checkbox"/> V360FP Rev. J	B5 "C" Inline & Subbase, Installation & Service Instructions
<input type="checkbox"/> V363B	B5 Series Valve, Solenoid & Pilot Body, Service Instructions
<input type="checkbox"/> V364CP	B5 Modular Manifold, Assembly Procedure
<input type="checkbox"/> V367EP Rev. 8	B5 Low Watt & Remote Pilot Series, Installation & Service Instructions
<input type="checkbox"/> V374EP Rev. 8	B3 Modular Manifold, Installation & Service Instructions
<input type="checkbox"/> V375BP	B3 Sandwich Regulator, Installation & Service Instructions
<input type="checkbox"/> V376BP Rev. 6	B3 Extruded Manifold, Installation & Service Instructions
<input type="checkbox"/> V377P	B3 to Slideair Valve Manifold Transition Plate, Installation & Service Instructions
<input type="checkbox"/> V378BP Rev. C	B5 Extruded Manifold, Assembly Procedure
<input type="checkbox"/> V381BP Rev. 3	B2 Valve, Installation & Service Instructions
<input type="checkbox"/> V390P	B3 "B" Inline & Subbase, Installation & Service Instructions
<input type="checkbox"/> V391P	B3 "B" 2-Position Inline & Subbase, Installation & Service Instructions
<input type="checkbox"/> V392P	B3 "B" 3-Position Inline & Subbase, Installation & Service Instructions
<input type="checkbox"/> V393BP	B3 "B" Replace Solenoid Assembly, Installation & Service Instructions
<input type="checkbox"/> V400BP Rev. 5	B3 "C" 3-Way Inline, 4-Way Inline & Subbase, Installation & Service Instructions
<input type="checkbox"/> V401CP Rev. 5	B3 "C" 2 & 3-Position Body & Operators, Inline & Subbase, Service Instructions
<input type="checkbox"/> V402EP Rev. J	Solenoid Replacement Kits, Service Instructions
<input type="checkbox"/> V420P	B2 "C" Inline & Subbase, Installation & Operation Instructions
<input type="checkbox"/> V421P	B2 "C" 2 & 3-Position Body & Operators, Service Instructions
<input type="checkbox"/> V423BP Rev. 3	B2 "C" Extruded Manifolds, Assembly Procedure
<input type="checkbox"/> V425P	B2 Sandwich Regulator, Installation Service Instructions
<input type="checkbox"/> V510FP Rev. 6	B6, B7, B8 Valves, Installation & Service Instructions
<input type="checkbox"/> V513CP Rev. 3	B6, B7, B8 Valves, Extruded Manifold, Assembly Procedure
<input type="checkbox"/> Safety Guide	PDN Safety Guide



Visit www.pdnplu.com for additional instruction sheets.



Pneumatic Division North America
 Richland, Michigan 49083

Installation Instructions:
V-339P
Isolator Plug For
A05 / A12 / B2 Manifold
ISSUED: October, 2000
Supersedes: None
NPR# R06920

! WARNING

To avoid unpredictable valve behavior that can cause personal injury and property damage:

- Disconnect electrical supply before installation, servicing, or conversion.
- Disconnect air supply and depressurize all air lines connected to this product before installation, servicing, or conversion.
- Operate within the manufacturer's specified pressure, temperature, voltage and other ratings listed on these instructions.
- Medium should be moisture-free if ambient temperature is below freezing.
- Service according to procedures listed on service sheets.
- Installation, service, and conversion of these products must be performed by knowledgeable personnel who understand how pneumatic valves are to be applied.
- After installation, servicing, or conversion, air and electrical supplies should be connected and the valve tested for proper function and leakage. If leakage is present or valve does not function properly, do not put into use.
- Warnings and specifications on the product should not be covered by paint, etc. If masking is not possible, contact your local representative for replacement labels.

Introduction

Follow these instructions, the unit's application limits, wiring instructions, and instructions for the proper installation of the valves and manifold that was included with the original valve and manifold. The following instructions are applicable. V-331CP (A05/A12 Subbase Valve & Manifold), V-330CP (A05/A12 Body Ported Valve & Manifold), V-421P (B2 Series Air Control Valves), V-423P (B2 Series Valve Extruded Manifolds). Copies of instruction forms are available from your local representative.

! CAUTION: It is recommended that the installation of isolation plugs be made before assembling valves. Before beginning, check galleries for any foreign debris. Bore to be grease free. Obstructions can prohibit proper installation, either by making it difficult for installation or having the isolation plug function improperly.

Assembly Procedure

Installing Isolation Plugs

1. Before inserting the isolation plug into the manifold (Figure 1), determine the best location and orientation for the isolator plug. The location and orientation of the plug may be affected by the length of the manifold and the length of available tools. Figure 2 and Figure 3 both show isolation between station 1 and 2. Note that there is a choice of orientation for the isolation plug.
2. Install the dowel pin in the station to be isolated. The dowel pin is used to locate the isolator plug for proper function.
3. Adjust tension on the socket head cap screw to allow o-rings to slide into the port without dragging on the inside diameter of the port. Gently install the isolator plug into the port. The isolator plug must be orientated such that the brass slotted end is facing the dowel pin.

4. Gently slide the isolator plug down the port until the brass slotted end is touching the dowel pin. If the isolator plug is snug, loosen the socket head cap screw.
5. Tighten the socket head cap screw per chart below. Pushing the isolator plug against the dowel pin will prevent the body from rotating while torque is applied to the socket head cap screw. If necessary, remove the dowel pin and use a screw driver to prevent the body from rotating. Use the screw driver for back up use only. Do not apply torque by turning the screwdriver. Always apply torque by turning the socket head cap screw.

Valve Series	Hex Wrench Size	Torque
A05 Isolator Plug	2.0mm	0.7 To 0.9 Nm (6 To 8 In-lb)
A12 Isolator Plug	2.5 mm	0.9 To 1.1 Nm (8 To 10 In-lb)
B2 Isolator Plug	2.5 mm	0.9 To 1.1 Nm (8 To 10 In-lb)

6. Remove dowel pin. Place each valve onto its corresponding base and assemble using instructions provided with valve. Make plumbing and electrical connections
7. When assembly is complete, turn on air pressure and check for external leakage. If leakage is audible (indicating improper installation), do not operate - conduct assembly again.

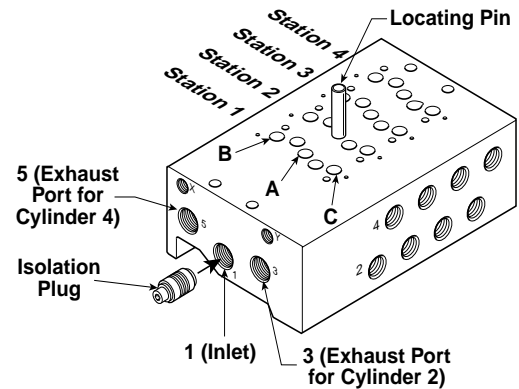

Figure 1

! WARNING

FAILURE OR IMPROPER SELECTION OR IMPROPER USE OF THE PRODUCTS AND/OR SYSTEMS DESCRIBED HEREIN OR RELATED ITEMS CAN CAUSE DEATH, PERSONAL INJURY AND PROPERTY DAMAGE.

This document and other information from Parker Hannifin Corporation, its subsidiaries and authorized distributors provide product and/or system options for further investigation by users having technical expertise. It is important that you analyze all aspects of your application, including consequences of any failure and review the information concerning the product or systems in the current product catalog. Due to the variety of operating conditions and applications for these products or systems, the user, through its own analysis and testing, is solely responsible for making the final selection of the products and systems and assuring that all performance, safety and warning requirements of the application are met.

The products described herein, including without limitation, product features, specifications, designs, availability and pricing, are subject to change by Parker Hannifin Corporation and its subsidiaries at any time without notice.

EXTRA COPIES OF THESE INSTRUCTIONS ARE AVAILABLE FOR INCLUSION IN EQUIPMENT / MAINTENANCE MANUALS THAT UTILIZE THESE PRODUCTS. CONTACT YOUR LOCAL REPRESENTATIVE.

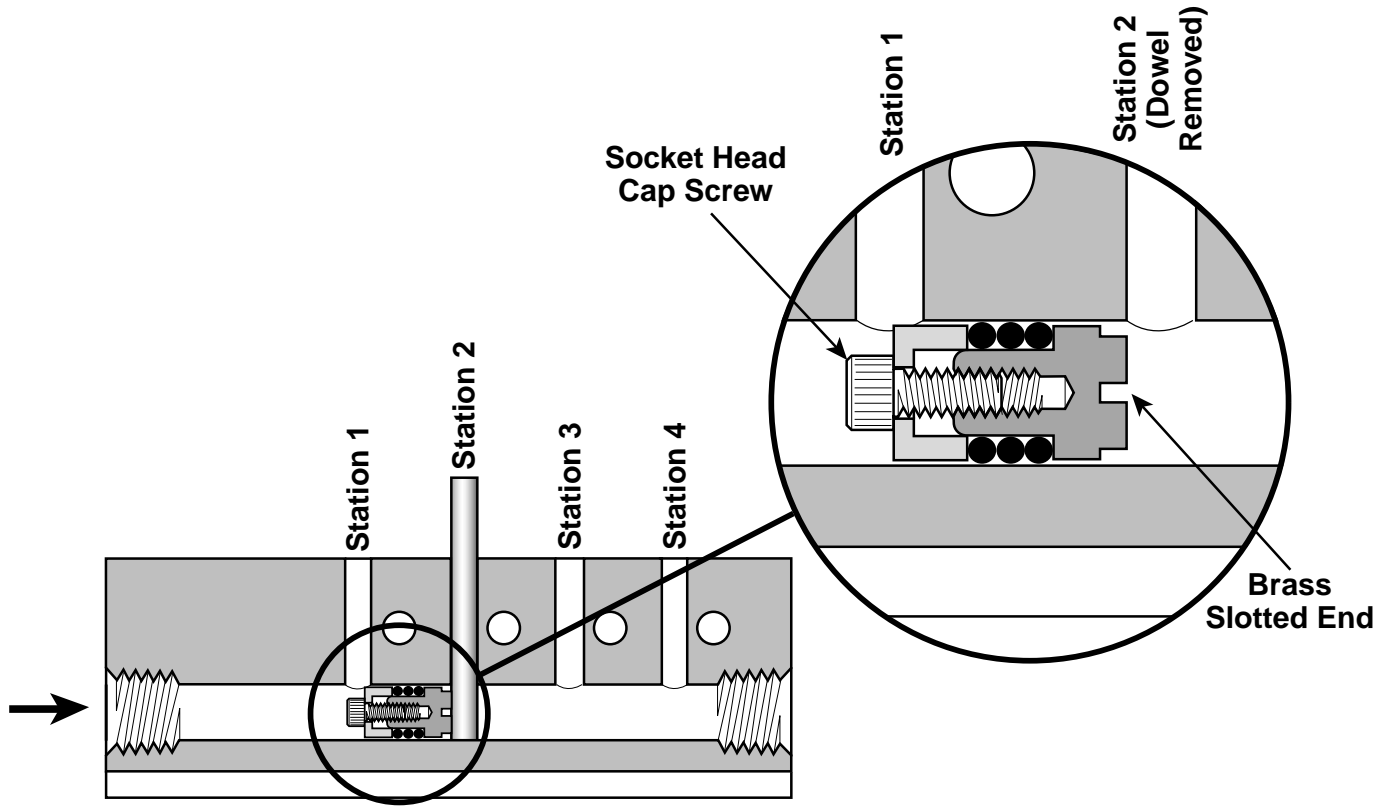

Figure 2

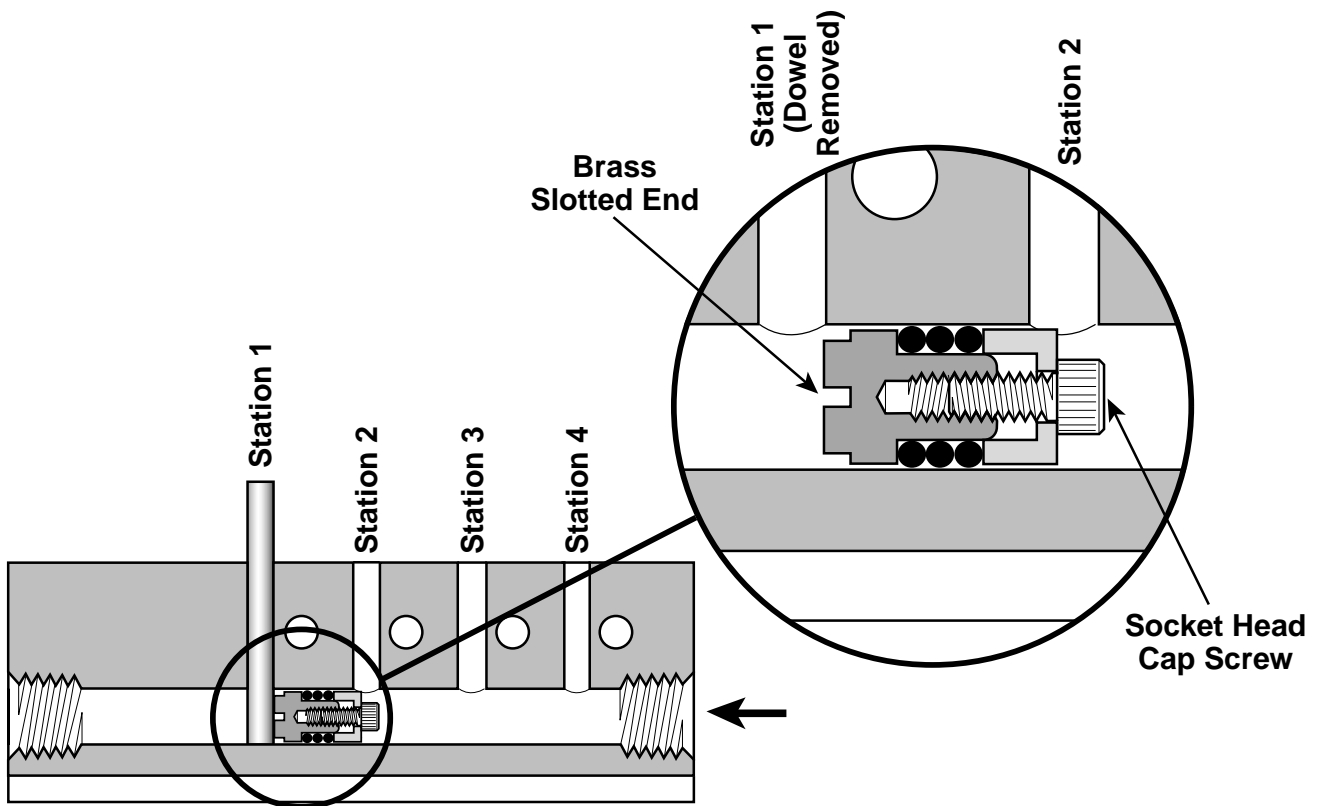

Figure 3



Pneumatic Division North America
 Richland, Michigan 49083

**Installation and Operation
 Instructions: V-355P**

“B4...A” Series Air Control Valves
 3-Way: Inline
 4-Way: Inline

ISSUED: March, 2001
Supersedes: None
NPR# 2009

⚠ WARNING

To avoid unpredictable system behavior that can cause personal injury and property damage:

- Disconnect electrical supply (when necessary) before installation, servicing, or conversion.
- Disconnect air supply and depressurize all air lines connected to this product before installation, servicing, or conversion.
- Operate within the manufacturer’s specified pressure, temperature, and other conditions listed in these instructions.
- Medium must be moisture-free if ambient temperature is below freezing.
- Service according to procedures listed in these instructions.
- Installation, service, and conversion of these products must be performed by knowledgeable personnel who understand how pneumatic products are to be applied.
- After installation, servicing, or conversion, air and electrical supplies (when necessary) should be connected and the product tested for proper function and leakage. If audible leakage is present, or the product does not operate properly, do not put into use.
- Warnings and specifications on the product should not be covered by paint, etc. If masking is not possible, contact your local representative for replacement labels.

Introduction

Follow these instructions when installing, operating, or servicing the product.

Application Limits

These products are intended for use in general purpose compressed air systems only.

Operating Inlet Pressure:

	kPa	psig	bar
Min. (2-Position)	140	20	1.4
Min. (2-Position w/Spring and Air Return)	240	35	2.4
Min. (3-Position)	210	30	2.1
Max. (2 & 3-Position)	1000	145	10.0

NOTE: Solenoid operated valves, when specified with external pilot, may have operating pressures down to vacuum in the main valve. External pilot pressure and air pilot signals must be greater than or equal to that in the main valve, but not outside the ratings above.

Ambient Temperature Range: -15°C to 50°C (5°F to 120°F)

Voltage Range: Rated Voltage +10%, -15%

Installation Instructions

Valve should be installed with reasonable accessibility for service. Exercise care in keeping pipe/tube lengths to a minimum. Plumbing should be free of dirt, chips, & scale. Pipe joint compound should be applied sparingly, and only to the male threads, never to the female threads. Protect the valve from exposure to extreme temperatures, dirt, and moisture to maximize life.

Series “B4...A” valves with integral PRESTOLOK ports must use Parker PARFLEX tubing, which has the required O.D. tolerances for use with PRESTOLOK ports. Be sure to use the tubing support (Part No. 63 PTU) when using the series ‘U’ polyurethane tubing. All applications should be carefully tested through the full range of conditions which may be encountered prior to use.

Air applied to the valve must be filtered to realize maximum component life.

⚠ CAUTION: It is recommended that double operated 2-Position valves be mounted so that the axis of the main valve spool is in the horizontal plane. The valve may be rotated to any angle around the axis for mounting convenience.

Factory Pre-Lubrication – All valves are pre-lubricated at the factory. In-service lubrication is recommended. Valves will operate without added lubrication but with reduced service life.

Manual Override:

A manual override (if supplied) is located on the body of the solenoid pilot, either on the same side or on the opposite side as the electrical terminals. A non-locking override is blue and must be twisted approx. 45° in either direction (and held at that position) in order to actuate the solenoid pilot. When released, the solenoid pilot will de-actuate. A flush type override requires use of a small screwdriver engaged in a slot on the end of the override button; a lever style override can be turned by finger. Locking overrides are yellow and must be twisted approx. 90° in either direction in order to actuate the solenoid pilot. They must be returned with a reverse twist to de-actuate. These are also either flush or extended types and operate as described above.

⚠ WARNING

FAILURE OR IMPROPER SELECTION OR IMPROPER USE OF THE PRODUCTS AND/OR SYSTEMS DESCRIBED HEREIN OR RELATED ITEMS CAN CAUSE DEATH, PERSONAL INJURY AND PROPERTY DAMAGE.

This document and other information from Parker Hannifin Corporation, its subsidiaries and authorized distributors provide product and/or system options for further investigation by users having technical expertise. It is important that you analyze all aspects of your application, including consequences of any failure and review the information concerning the product or systems in the current product catalog. Due to the variety of operating conditions and applications for these products or systems, the user, through its own analysis and testing, is solely responsible for making the final selection of the products and systems and assuring that all performance, safety and warning requirements of the application are met.

The products described herein, including without limitation, product features, specifications, designs, availability and pricing, are subject to change by Parker Hannifin Corporation and its subsidiaries at any time without notice.

EXTRA COPIES OF THESE INSTRUCTIONS ARE AVAILABLE FOR INCLUSION IN EQUIPMENT / MAINTENANCE MANUALS THAT UTILIZE THESE PRODUCTS. CONTACT YOUR LOCAL REPRESENTATIVE.

In-Service Lubrication:

Parker F442P oil is recommended. This is specially formulated to provide peak performance and maximum service life from all air operated equipment. Alternate compatible lubricants should be a paraffin based mineral oil having 150 to 200 SSU viscosity @ 100°F and an aniline point greater than 200°F. (Mobil DTE24 and Sun Company Sunvis 932 are good examples.)

CAUTION: Do not use synthetic, reconstituted, or oils with an alcohol content or detergent additives.

Symbols

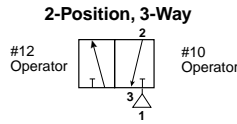

Note: For single solenoid or single air pilot operated valves, that operator is located on the 12 end for normally closed (NC) operation, and on the 10 end for normally open (NO) operation.

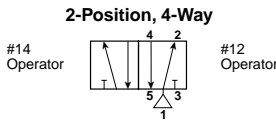

Single & Double Solenoid

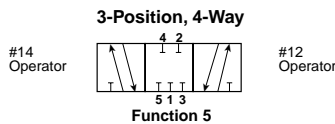

Function 5

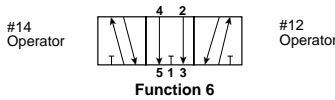

Function 6

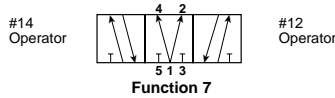

Function 7

Port Identification

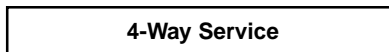

Port No.	Single Pressure	Dual Pressure
1	Inlet	Exhaust
2	Cylinder	Cylinder
3	Exhaust	Inlet
4	Cylinder	Cylinder
5	Exhaust	Inlet

NOTE: For valves specified for dual pressure, the highest pressure is to be at port #3.

4-Way valves may be used for 3-Way function by plugging an outlet port.

NOTE: The operator identification describes the ports that are connected when the operator is energized: operator 12 connects port 1 to port 2; operator 14 connects port 1 to port 4; port 1 is isolated when operator 10 is energized. Other ports may also be connected, or blocked – see symbols.

Wiring

Attach an electrical cable with connector (that conforms to the DIN 43650, Form C pattern) to the terminals of the solenoid. For locations in a cabinet or other protected environment, the Snap-On connector with loose wires may be attached. In both cases, do not attach or remove the connectors until power is off.

Follow all requirements for local and national electrical codes.

Electrical Connection:

Valves with 3-pin male terminals should have power connected to the parallel terminals. Ground should be connected to the perpendicular terminal. Use only connectors that comply with DIN 43650, Form C (8mm blade spacing).

Accessories:

Kit No.	Description
PS298305P	Snap on Connector Kit with 0.5 meter wires
PS298320P	Snap on Connector Kit with 2 meter wires
PS4515P	Manifold End Plate Kit (4-Way valve)
PS4517P	Manifold <u>without</u> Flow Control Kit (4-Way valve)
PS4518P	Manifold with Flow Control Kit (4-Way valve)
PS4519P	Isolation Plug Kit
PS4520P	Inlet Block/Blanking Plate Kit (4-Way valve)
PS2932P	3-Pin Connector Kit - Unlighted
PS294675P	3-Pin Connector Kit - Lighted, 12VAC & DC
PS294679P	3-Pin Connector Kit - Lighted, 24VAC & DC
PS294683P	3-Pin Connector Kit - Lighted, 120VAC
PS2932JP	3-Pin Connector Kit - Unlighted with 2 meter cord
PS2946J75P	3-Pin Connector Kit - Lighted, 12VAC & DC with 2 meter cord
PS2946J79P	3-Pin Connector Kit - Lighted, 24VAC & DC with 2 meter cord
PS2946J83P	3-Pin Connector Kit - Lighted, 120VAC with 2 meter cord
PS4550P	IEM Manifold End Plate Kit (3-Way valve)
PS4552P	IEM Manifold End Plate Kit - External Pilot Supply (3-Way valve)
PS4548P	IEM Manifold <u>without</u> Flow Control Kit (3-Way valve)
PS4549P	IEM Manifold <u>with</u> Flow Control Kit (3-Way valve)
PS4568P	IEM Manifold Blanking Kit (3-Way valve)
PS4566P	IEM Manifold Intermediate Supply Kit (3-Way valve)

Service Kits Available

The following service kits contain the appropriate seals and parts necessary for ordinary field service.

Kit No.	Description
PS4501P	2-Position body service kit (4-Way valve)
PS4502P	3-Position all ports blocked body service kit (4-Way valve)
PS4503P	3-Position cylinder to exhaust body service kit (4-Way valve)
PS4504P	3-Position pressure center body service kit (4-Way valve)
PS4571P	Body Service Kit (3-Way valve)
PS2982AXX*P	Solenoid Kit - No Override
PS2982BXX*P	Solenoid Kit - Non-Locking Flush Override
PS2982CXX*P	Solenoid Kit - Locking Flush Override
PS2982DXX*P	Solenoid Kit - Non-Locking Extended Override
PS2982EXX*P	Solenoid Kit - Locking Extended Override

When ordering solenoid service kits specify two digit solenoid voltage code (XX) and if needed, interface relationship (*) to complete model number. Code keys are as given below:

XX - Voltage code key

Code	Voltage
40	12 Volt 60Hz, 12 Volt 50Hz
42	24 Volt 60Hz, 22 Volt 50Hz
45	12 Volt DC
49	24 Volt DC
53	120 Volt 60Hz, 115 Volt 50Hz

* Solenoid electrical pin and base interface relationship codes:

Blank	Solenoid pins up, opposite valve interface (standard location)
2	Solenoid pins down, on same side as valve interface



Pneumatic Division
 Richland, Michigan 49083

Installation & Service Instructions
V-356P

“B4” Series Valves

ISSUED: June, 2001
Supersedes: None
ECN# P28319

WARNING

To avoid unpredictable system behavior that can cause personal injury and property damage:

- Disconnect electrical supply (when necessary) before installation, servicing, or conversion.
- Disconnect air supply and depressurize all air lines connected to this product before installation, servicing, or conversion.
- Operate within the manufacturer’s specified pressure, temperature, and other conditions listed in these instructions.
- Medium must be moisture-free if ambient temperature is below freezing.
- Service according to procedures listed in these instructions.
- Installation, service, and conversion of these products must be performed by knowledgeable personnel who understand how pneumatic products are to be applied.
- After installation, servicing, or conversion, air and electrical supplies (when necessary) should be connected and the product tested for proper function and leakage. If audible leakage is present, or the product does not operate properly, do not put into use.
- Warnings and specifications on the product should not be covered by paint, etc. If masking is not possible, contact your local representative for replacement labels.

General Installation & Operating Instructions

Keep pipe or tubing clean and free of dirt and chips. Pipe joint compound should be used sparingly and applied only to the male pipe - never into the female port. Do not use PTFE tape to seal pipe joints - pieces have a tendency to break off and lodge inside the unit, possibly causing malfunction.

Application Limits (2-Position)

Operating Pressure:

	kPa	PSIG	bar
Minimum	138	20	1.4
Maximum	1030	145	10.0

Application Limits (3-Position)

Operating Pressure:

	kPa	PSIG	bar
Minimum	207	30	2.1
Maximum	1030	145	10.0

NOTE: Solenoid operated valves specified for external pilot or double air pilot operated valves may have pressures down to vacuum in the main valve. External pilot pressure must be greater than or equal to that in the main valve, but not exceed the ranges above.

Ambient Temperature Range: -15°C to 49°C (5°F to 120°F)

Voltage Range: Rated Voltage +10, -15%

CAUTION: An interruption of 10 milliseconds or greater to the power supplied to the solenoid of a solenoid operated valve may cause the valve to shift. Provision must be made to prevent power interruption of this duration to avoid unintended, potentially hazardous, consequences.

Lubrication

Filtered and lubricated air is necessary for maximum valve life and minimum maintenance. In-service lubrication is used, lubricate with a straight paraffin based mineral oil having an ISO viscosity grade of 32 (e.g. Sunvis 932).

NOTE: Once in-service lubrication is initiated, the practice should be continued in order to maximize valve life.

Maintenance & Trouble Shooting Hints

Valve Not Shifting Completely When Energized:

1. Check to insure that the proper voltage is supplied to the solenoids.
2. Check to insure that supply pressure is 138 kPa (20 PSIG) or greater at the valve’s inlet when shifting valve.
3. Check for possible restrictions in air supply, such as undersized hoses, fittings, or quick disconnects.
4. Check to insure that the spool moves smoothly.
5. Check spool seals for proper installation, dirt, or damage.

Air Leakage Through Exhaust Ports:

1. Check for internal leakage in the cylinder being operated by the valve.
2. Check condition of the spool seals for proper alignment, damaged (nicked or broken) seals and dirt contamination.
3. Check for missing, damaged, or incorrectly assembled o-rings and gaskets.

If installing new spool: Remove old spool assembly, taking care not to scratch bore. Install new spool assembly into clean bore, taking care to install squarely and push slowly to avoid damaging seals or the valve bore.

If installing new piston: Refer to drawing for proper orientation. Install piston/seal assembly into the operator bore, taking care to assure the lips of the seal pass smoothly into the bore.

- Lightly grease with provided lubricant.
 - Inspect for nicks, scratches, and surface imperfections. If present, reduced service life is probable and future replacement should be planned.
 - Clean with lint-free cloth.
- * If more aggressive cleaning is required, use mineral spirits or equivalent solvent and dry thoroughly.

WARNING

FAILURE OR IMPROPER SELECTION OR IMPROPER USE OF THE PRODUCTS AND/OR SYSTEMS DESCRIBED HEREIN OR RELATED ITEMS CAN CAUSE DEATH, PERSONAL INJURY AND PROPERTY DAMAGE.

This document and other information from Parker Hannifin Corporation, its subsidiaries and authorized distributors provide product and/or system options for further investigation by users having technical expertise. It is important that you analyze all aspects of your application, including consequences of any failure and review the information concerning the product or systems in the current product catalog. Due to the variety of operating conditions and applications for these products or systems, the user, through its own analysis and testing, is solely responsible for making the final selection of the products and systems and assuring that all performance, safety and warning requirements of the application are met.

The products described herein, including without limitation, product features, specifications, designs, availability and pricing, are subject to change by Parker Hannifin Corporation and its subsidiaries at any time without notice.

EXTRA COPIES OF THESE INSTRUCTIONS ARE AVAILABLE FOR INCLUSION IN EQUIPMENT / MAINTENANCE MANUALS THAT UTILIZE THESE PRODUCTS. CONTACT YOUR LOCAL REPRESENTATIVE.



Pneumatic Division
 Richland, Michigan 49083

Assembly Procedure: V-357P

**“B4” Series Valve
 Modular Manifold**

**ISSUED: June, 2001
 Supersedes: None**

ECN# P28319

WARNING

To avoid unpredictable system behavior that can cause personal injury and property damage:

- Disconnect electrical supply (when necessary) before installation, servicing, or conversion.
- Disconnect air supply and depressurize all air lines connected to this product before installation, servicing, or conversion.
- Operate within the manufacturer’s specified pressure, temperature, and other conditions listed in these instructions.
- Medium must be moisture-free if ambient temperature is below freezing.
- Service according to procedures listed in these instructions.
- Installation, service, and conversion of these products must be performed by knowledgeable personnel who understand how pneumatic products are to be applied.
- After installation, servicing, or conversion, air and electrical supplies (when necessary) should be connected and the product tested for proper function and leakage. If audible leakage is present, or the product does not operate properly, do not put into use.
- Warnings and specifications on the product should not be covered by paint, etc. If masking is not possible, contact your local representative for replacement labels.

WARNING

Air exhausting from one valve into the exhaust gallery of the manifold may pressurize other valve circuits open to the same gallery. Design the circuit such that there is no hazard or damage consequence from this action.

Introduction

Follow these instructions when installing, operating, or servicing the product.

CAUTION: Solenoid versions of this valve contain solid state components that can be damaged by transient voltage spikes, over-voltage or high temperature. To protect against premature solenoid failure, please read and adhere to the following:

1. If this solenoid operated valve is used in a circuit with other inductive loads. The solenoid should be electrically protected with a voltage suppression device (e.g. transient voltage suppressor or varistor) that has a minimum rating of 1.6 times the rated voltage of the solenoid valve and sufficient capacity to dissipate the energy of other inductive loads.
2. Operating voltage is 90-110% of rated voltage. These limits should not be exceeded.

Application limits, wiring instructions, and instructions for the proper installation of the valves for this manifold are shown in instruction form V355P, which was shipped with the valve. Service kits and other service instruction sheets are also referenced on this form.

Manifold End Plate Kit (4-Way)	PS2815P
Manifold End Plate Kit (3-Way)	PS4550P
Manifold w/o Flow Control Kit (4-Way)	PS4517P
Manifold w/ Flow Control Kit (4-Way).....	PS4518P
Manifold w/o Flow Control Kit (3-Way)	PS4548P
Manifold w/ Flow Control Kit (3-Way).....	PS4549P

**Assembly Procedure:
 Modular Manifold and End Plates**

Notes:

1. Assemblies can be made with or without valves (or inlet block/blanking plates) installed.
2. Valves can be installed in one of two positions on manifolds for 4-Way. It is recommended valves be installed so outlet ports #4 are all in line. When valves are installed on a complete manifold assembly, the port on the end plate marked 5/3 or 3/5 nearest port #4 on the installed valves is port #5. The port on the end plate marked 3/5 or 5/3 nearest port #2 on the installed valve is port #3. For 3-Way valves, the port #1 on the valve must line up with port #1 on the manifold.
3. If isolator plugs are being used, they should be installed per the instructions on the reverse side while the manifold is being assembled.
4. Manifolds with flow controls should not be used for dual pressure applications.

Assembly:

1. Pre-assemble tie rods (Item #4) into 2 assemblies of equal length. For assemblies of 10 or more manifold bases, it may be necessary to back off one turn between tie rod shoulder-to-shoulder connection in order for tie rod screws to have initial engagement. Thread assemblies into end plate with o-ring grooves (Item #6).
2. Place end plate(s) with threaded assemblies on a flat surface with the o-ring grooves facing up and the tie rod assemblies vertical.
3. Install o-rings (Item #5) into grooves in end plate(s).
4. Slide the first base over the tie rods with its o-ring grooves facing up.
5. Install seal (Item #10) into the unit just assembled and repeat the above procedure until all valves are assembled.

WARNING

FAILURE OR IMPROPER SELECTION OR IMPROPER USE OF THE PRODUCTS AND/OR SYSTEMS DESCRIBED HEREIN OR RELATED ITEMS CAN CAUSE DEATH, PERSONAL INJURY AND PROPERTY DAMAGE.

This document and other information from Parker Hannifin Corporation, its subsidiaries and authorized distributors provide product and/or system options for further investigation by users having technical expertise. It is important that you analyze all aspects of your application, including consequences of any failure and review the information concerning the product or systems in the current product catalog. Due to the variety of operating conditions and applications for these products or systems, the user, through its own analysis and testing, is solely responsible for making the final selection of the products and systems and assuring that all performance, safety and warning requirements of the application are met.

The products described herein, including without limitation, product features, specifications, designs, availability and pricing, are subject to change by Parker Hannifin Corporation and its subsidiaries at any time without notice.

EXTRA COPIES OF THESE INSTRUCTIONS ARE AVAILABLE FOR INCLUSION IN EQUIPMENT / MAINTENANCE MANUALS THAT UTILIZE THESE PRODUCTS. CONTACT YOUR LOCAL REPRESENTATIVE.

6. Assemble the remaining end plate(s) with the flat washers (Item #3), lock washers (Item #2), and tie rod screws (Item #1). Tighten screws to 4.5 to 5.1 Nm (40 to 45 in. lb.) torque using 4mm hex wrench. (It may be beneficial to only snug tie rod screws, place the assembly horizontal, assure squareness, and then finally tighten tie rod screws.)
7. Place assembly horizontal with o-ring grooves facing up. Install seal into counterbore.
8. Place each valve onto its corresponding base and fasten with socket head cap screws (Item #7). Tighten screws to 2.3 to 3.4 Nm (20 to 30 in. lb.) torque using 3mm hex wrench.
9. Make plumbing and electrical connections.
10. Turn on air pressure and electrical power source. Test for proper functional operation and for internal and external air leakage. If leakage is audible (indicating improper assembly is likely), do not operate - conduct assembly again.

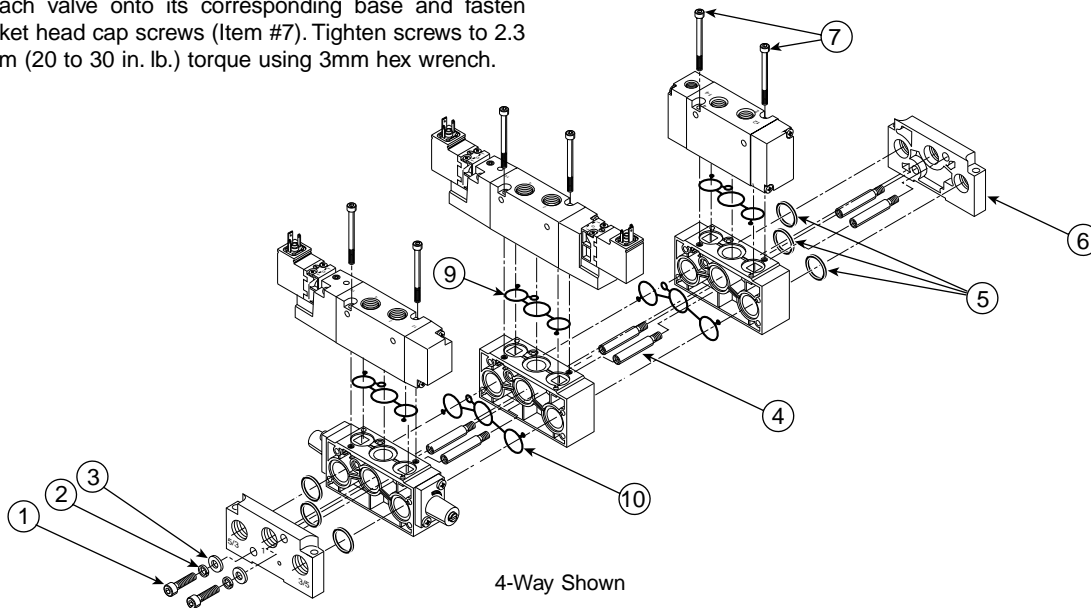

Isolator Plug Kit PS4519P

1. If isolator plugs are to be used in an assembly, they should be installed while the modular manifold is being assembled per the instructions on the reverse side.
2. Each kit contains three (3) plug and o-ring assemblies (Item #11). Plugs may be installed in any one, or all three of the common galleys in the assembly, or any combination thereof. Please consult your specific circuit diagram to determine the proper number and location of plugs to be used. Extra plugs may be discarded.
3. Lightly grease (provided) the plug o-rings and install one end into the proper bore in the manifold. When installing the next manifold base, care should be taken to assure the exposed end of the plug enters the manifold bore without cutting the o-ring.
4. When assembly is complete, turn on air pressure and check for external leakage, as well as leakage across the isolator plug by pressurizing one side and check for leakage at the other side. If leakage is audible (indicating improper assembly is possible), do not operate - perform assembly again.

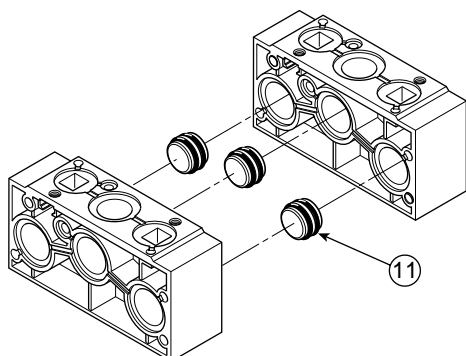

Inlet Block / Blanking Plate Kit - PS4520P

1. Install seal (Item #12), provided with base, into counterbore on top of manifold base.
2. Place flat surface of plate (Item #13) (opposite port countersinks) onto manifold and install two (2) hold down screws (Item #14). Tighten screws to 2.3 to 3.4 Nm (20 to 30 in. lb.) torque using 3mm hex wrench.
3. If being used as a blanking plate, install three (3) pipe plugs (Item #15) into ports.
4. If being used for single pressure intermediate supply, install one pipe plug (Item #15) into two outside ports. Supply connection to common galley #1 is made to center port.
5. If being used for dual pressure intermediate supply, install one (1) pipe plug (Item #15) into center port. Supply pressures are supplied to the two outside ports. The higher pressure is to be supplied to the port nearest port #2 on other valves in the assembly.
6. If being used for additional exhaust ports, install one (1) pipe plug (Item #15) into the center port for single pressure systems or two (2) pipe plugs (Item #15) into the two outside ports for dual pressure systems.
7. Turn on air pressure and check for leakage. If leakage is audible (indicating improper assembly is likely), do not operate - conduct assembly again.

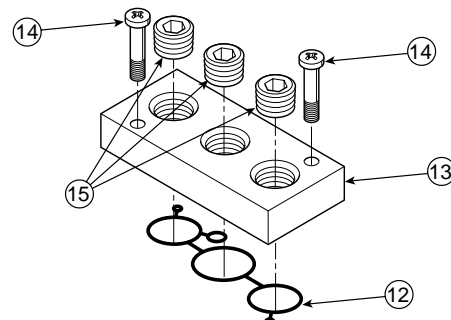



Pneumatic Division
Richland, Michigan 49083

Installation & Service Instructions
V360FP
"B5C" Series Air Control Valves
1/4" & 3/8" Inline & Subbase
ISSUED: January, 2017
Supersedes: September, 2008
Doc.# V360P, EN# 170160, Rev. J

⚠ WARNING

To avoid unpredictable system behavior that can cause personal injury and property damage:

- Disconnect electrical supply (when necessary) before installation, servicing, or conversion.
- Disconnect air supply and depressurize all air lines connected to this product before installation, servicing, or conversion.
- Operate within the manufacturer's specified pressure, temperature, and other conditions listed in these instructions.
- Medium must be moisture-free if ambient temperature is below freezing.
- Service according to procedures listed in these instructions.
- Installation, service, and conversion of these products must be performed by knowledgeable personnel who understand how pneumatic products are to be applied.
- After installation, servicing, or conversion, air and electrical supplies (when necessary) should be connected and the product tested for proper function and leakage. If audible leakage is present, or the product does not operate properly, do not put into use.
- Warnings and specifications on the product should not be covered by paint, etc. If masking is not possible, contact your local representative for replacement labels.

Safety Guide

For more complete information on recommended application guidelines, see the Safety Guide section of Pneumatic Division catalogs or you can download the **Pneumatic Division Safety Guide** at: www.parker.com/safety

Introduction

Follow these instructions when installing, operating, or servicing the product.

Application Limits

These products are intended for use in general purpose compressed air systems only.

Application Limits (2-Position)

Operating Pressure:	kPa	PSIG	bar
Minimum	138	20	1.4
Maximum	1030	145	10.0

Application Limits (3-Position)

Operating Pressure:	kPa	PSIG	bar
Minimum	207	30	2.1
Maximum	1030	145	10.0

NOTE: Solenoid operated valves specified for external pilot or double air pilot operated valves may have pressures down to vacuum in the main valve. External pilot pressure and air pilot signals must be greater than or equal to that in the main valve, but not exceed the ranges above.

Ambient Temperature Range: -15°C to 49°C (5°F to 120°F)

Voltage Range: Rated Voltage ±10%

⚠ CAUTION: An interruption of 10 milliseconds or greater to the power supplied to the solenoid of a solenoid operated valve may cause the valve to shift. Provision must be made to prevent power interruption of this duration to avoid unintended, potentially hazardous, consequences.

Maintenance & Trouble Shooting Hints

Valve Not Shifting Completely When Energized:

1. Check to insure that the proper voltage is supplied to the solenoids.
2. Check to insure that supply pressure is 138 kPa (20 PSIG) or greater at the valve's inlet when shifting valve.
3. Check for possible restrictions in air supply, such as undersized hoses, fittings, or quick disconnects.
4. Check to insure that the spool moves smoothly.
5. Check spool seals for proper installation, dirt, or damage.

Air Leakage Through Exhaust Ports:

1. Check for internal leakage in the cylinder being operated by the valve.
2. Check condition of the spool seals for proper alignment, damaged (nicked or broken) seals and dirt contamination.
3. Check for missing, damaged, or incorrectly assembled o-rings and gaskets.

Lubrication

Filtered and lubricated air is necessary for maximum valve life and minimum maintenance. If in-service lubrication is used, lubricate with a straight paraffin based mineral oil having an ISO viscosity grade of 32 (e.g. Sunvis 932).

NOTE: Once in-service lubrication is initiated, the practice should be continued in order to maximize valve life.

Wiring

Follow all requirements for local and national electrical codes.

Electrical Connection:

1. Valve with lead wires should have power connected to the black wires. Ground should be connected to the green wire if provided.
2. Valves with 3-Pin male terminals should have power connected to the parallel terminals. Ground should be connected to the perpendicular terminal.
3. Valves with Mini Automotive Connector:
 - A. 3-Pin; power should be connected to #2 and #3 terminals. Ground should be connected to #1 terminal.
 - B. 5-Pin; power should be connected to #1 and #5 terminals. Ground should be connected to #3 terminal.

⚠ WARNING

FAILURE OR IMPROPER SELECTION OR IMPROPER USE OF THE PRODUCTS AND/OR SYSTEMS DESCRIBED HEREIN OR RELATED ITEMS CAN CAUSE DEATH, PERSONAL INJURY AND PROPERTY DAMAGE.

This document and other information from Parker Hannifin Corporation, its subsidiaries and authorized distributors provide product and/or system options for further investigation by users having technical expertise. It is important that you analyze all aspects of your application, including consequences of any failure and review the information concerning the product or systems in the current product catalog. Due to the variety of operating conditions and applications for these products or systems, the user, through its own analysis and testing, is solely responsible for making the final selection of the products and systems and assuring that all performance, safety and warning requirements of the application are met.

The products described herein, including without limitation, product features, specifications, designs, availability and pricing, are subject to change by Parker Hannifin Corporation and its subsidiaries at any time without notice.

EXTRA COPIES OF THESE INSTRUCTIONS ARE AVAILABLE FOR INCLUSION IN EQUIPMENT / MAINTENANCE MANUALS THAT UTILIZE THESE PRODUCTS. CONTACT YOUR LOCAL REPRESENTATIVE.



Pneumatic Division North America
 Richland, Michigan 49083

Service Instructions: V-363BP

**"B5" Series Air Control Valves
 Solenoid and Pilot Body
 1/4" & 3/8" Inline & Subbase**

**ISSUED: October, 1997
 Supersedes: June, 1997
 ECN# P26343**

! WARNING

To avoid unpredictable valve behavior that can cause personal injury and property damage:

- Disconnect air supply and depressurize all air lines connected to this product before installation, servicing, or conversion.
- Disconnect electrical supply before installation, servicing, or conversion.
- Operate within the manufacturer's pressure, temperature, voltage and other ratings listed on these instructions.
- Medium should be moisture-free if ambient temperature is below freezing.
- Service according to procedures listed on service instruction sheets.
- Installation, service, and conversion of these products must be performed by knowledgeable personnel who understand how pneumatic valves are to be applied.
- After installation, servicing, or conversion, air and electrical supplies should be connected and the valve tested for proper function and leakage. If leakage is present or valve does not function properly, do not put into use.
- Warnings and specifications on the product should not be covered by paint, etc. If masking is not possible, contact your local representative for replacement labels.

Introduction

Follow these instructions when installing, operating, or servicing the product.

Application Limits (2-Position)

Operating Pressure	kPa	psig	bar
Minimum	138	20	1.4
Maximum	1030	150	10.3

Application Limits (3-Position)

Operating Pressure	kPa	psig	bar
Minimum	207	30	2.1
Maximum	1030	150	10.3

NOTE: Solenoid operated valves specified for external pilot or double air pilot operated valves may have pressures down to vacuum in the main valve. External pilot pressure and air pilot signals must be greater than or equal to that in the main valve, but not exceed the ranges above.

Ambient Temperature Range: -18°C to 49°C (0°F to 120°F)

Voltage Range: Rated Voltage +10%, -15%

Wiring instructions and instructions for proper installation are shown on instruction form V-360P which is shipped with the original product. Copies of instruction form V-360P are available from your local representative.

Installation



Caution: Solenoid versions of this valve contain solid state components that can be damaged by transient voltage spikes, over-voltage or high temperature. To protect against premature solenoid failure, please read and adhere to the following:

1. If this solenoid operated valve is used in a circuit with other inductive loads. The solenoid should be electrically protected with a voltage suppression device (e.g. transient voltage suppressor or varistor) that has a minimum rating of 1.6 times

the rated voltage of the solenoid valve and sufficient capacity to dissipate the energy of other inductive loads.

2. Operating voltage is 85-110% of rated voltage. These limits should not be exceeded.

Servicing Solenoid Pilot Body Section:

1. Remove solenoid cover by loosening two (2) cover/body screws (item #29).
2. Remove armature assembly (item #26) and spring (item #25) from coil assembly.
3. Remove existing gasket (item #28) by peeling the gasket from the pilot body.
4. Remove o-ring (item #37) from groove in pilot body. Remove pilot body from main valve body by removing two (2) pilot body/pilot body screws.
5. Remove piston (item #9), seal (item #10), poppet spring (item #23), poppet seal (item #22), and seal carrier (item #21) from piston bore of pilot body.
6. Remove gasket (item #6) from pilot body.
7. Clean piston bore, armature bore, and gasket surface with lint free cloth. (If more aggressive cleaning is required, use mineral spirits or equivalent solvent and dry thoroughly.) Inspect piston bore and poppet seats for nicks, scratches or material imperfections. If present, reduced service life is probable and future replacement should be planned. Apply a thin film of grease (provided) to piston bore.
8. Apply a light film of grease to large flat surface of new poppet seal (item #22) and lightly press into new seal carrier (item #21) with the larger flat surface of the seal going onto the pocket first - facing in the direction of the legs of the carrier.
9. Apply a thin film of grease to new gasket (item #6) and place onto gasket track on main body end of pilot body. The seal should be lightly pressed into the track, pushing knob projections into operator slot.
10. Place new spring (item #23) onto poppet seal with the end of the spring with more inactive coils against the poppet seal, assuring it is firmly seated and insert legs of carrier through 2 small holes of pilot body from piston bore end.

! WARNING

FAILURE OR IMPROPER SELECTION OR IMPROPER USE OF THE PRODUCTS AND/OR SYSTEMS DESCRIBED HEREIN OR RELATED ITEMS CAN CAUSE DEATH, PERSONAL INJURY AND PROPERTY DAMAGE.

This document and other information from Parker Hannifin Corporation, its subsidiaries and authorized distributors provide product and/or system options for further investigation by users having technical expertise. It is important that you analyze all aspects of your application, including consequences of any failure and review the information concerning the product or systems in the current product catalog. Due to the variety of operating conditions and applications for these products or systems, the user, through its own analysis and testing, is solely responsible for making the final selection of the products and systems and assuring that all performance, safety and warning requirements of the application are met.

The products described herein, including without limitation, product features, specifications, designs, availability and pricing, are subject to change by Parker Hannifin Corporation and its subsidiaries at any time without notice.

EXTRA COPIES OF THESE INSTRUCTIONS ARE AVAILABLE FOR INCLUSION IN EQUIPMENT / MAINTENANCE MANUALS THAT UTILIZE THESE PRODUCTS. CONTACT YOUR LOCAL REPRESENTATIVE.

"B5" Series Air Control Valves

V-363BP

11. Clean the existing piston. Apply a thin film of grease to all surfaces of the new piston seal and place onto the piston, with the lips of the seal facing away from the support flange. For 3-position valves, the lips face away from the piston end where the nose enters into the main valve body bore. Install the piston/seal assembly into the piston bore, taking care to assure the lips of the seal pass smoothly into the bore and the spring (item #23) enters the pocket of the molded shape in the mechanism. Refer to illustrations for proper part orientations.
12. Reassemble the pilot body to the main valve body using screws. Assure the side of the pilot body with the manual override hole and the port marked PILOT are on the same side of the main valve body as the ports marked #2 and #4. Tighten the two (2) pilot body/body screws to 1.7 N•m (15 in-lbs) torque.
13. Peel backing from new gasket (item #28) and lightly place on pilot body noting proper orientation.
14. Install new o-ring (item #37) into groove in the pilot body.
15. Apply a thin film of grease to the outside surface of the armature assembly and armature spring. Install the spring into the armature assembly and place this assembly into the coil bore with spring end first. Place solenoid cover assembly onto pilot body. Normal orientation of solenoid leads is to the side of the main valve body with ports marked #4 and #2. Please note proper orientation for the specific location in question. Tighten the two (2) cover/body screws to 2.3 N•m (20 in-lbs) torque.
16. Turn on air pressure and electrical power source. Test valve for functional operation and internal and external leakage. If leakage is audible (indicating improper repairs are likely), do not operate - conduct repairs again.

of the new armature assembly and the armature spring. Install the spring (item #25) into armature assembly (item #26) and place this assembly into the coil bore with spring end first.

5. Reassemble solenoid cover with previously assembled parts and tighten the two (2) cover/body screws (item #29) to 2.3 to 2.8 N•m (20 to 25 in-lbs) torque.
6. Turn on air pressure and electrical power source. Test valve for functional operation and internal and external leakage. If leakage is audible (indicating improper repairs are likely), do not operate - conduct repairs again.

Converting Solenoid Voltage:

1. Follow steps 1, 2, 4, 5 & 6 from above.
2. Place new label on solenoid cover.
3. Permanently alter coil suffix on valve body label.

Servicing Valve Body:

The following service kits are available.

PS2801P	2-Position body service kit, 4-way
PS2871P	Body service kit, 3-way
PS2802P	3-Position all ports blocked body service kit
PS2803P	3-Position cylinder to exhaust body service kit
PS2804P	3-Position pressure center body service kit

Instructions for the above are contained on service instruction sheets V-361P, and V-362P, which are included in the kits.

Other Service Instruction Sheets

V-364P Manifold & accessory instruction sheet

Servicing Solenoid Section:

1. Remove solenoid cover by loosening two (2) cover/body screws. Remove armature assembly (item #26) and armature spring (item #25).
2. Remove the coil/frame assembly (item #41) from solenoid cover by positioning the coil bore in a downward direction and lightly tapping the edge of the cover on a solid surface.
3. Remove existing gasket (item #28) by peeling the gasket from the pilot body. Clean the gasket surface. Peel the backing from the new gasket and lightly place on the pilot body, noting proper orientation. Remove existing o-ring (item #37) from groove in pilot body. Clean groove and install new o-ring.
4. Note the new coil/frame assembly is pre-assembled and should not be disassembled. Verify the voltage on the service kit matches that marked on the solenoid cover label. Place the new assembly carefully into the cover and engage the contact pins into the receptacle sockets. Apply a thin film of grease (provided) to the outside surface

Accessories:

Kit No.	Description
PS2815P	Manifold end plate kit
PS2817P	Manifold w/o flow control kit
PS2818P	Manifold w/flow control kit
PS2819P	Isolation plug kit
PS2820P	Inlet block/blanking plate kit
PS2822P	Common conduit end plate kit

Service Instructions:

Subbase Valves

If valves are removed from their bases during repair, reassemble valve to base noting proper gasket orientation. Reinstall the two (2) socket head cap screws and tighten to 3.9 N•m (35 in-lbs) torque using 3mm hex wrench. Test the assembly for proper function and leakage before putting into service.

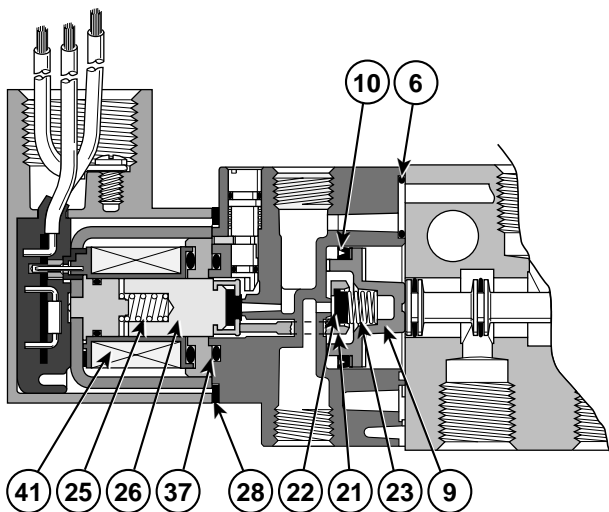

2-Position

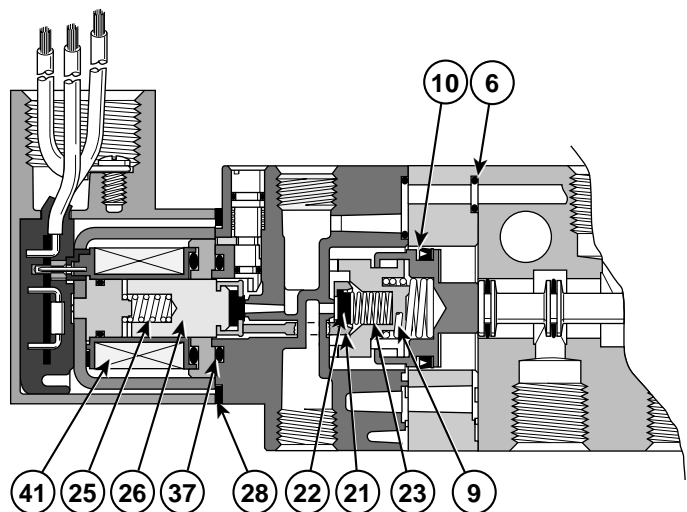

3-Position



Pneumatic Division North America
Richland, Michigan 49083

Assembly Procedure: V-364CP

“B5” Series Valve
Modular Manifold

ISSUED: September, 1998

Supersedes: July, 1998

ECN# P26720

! WARNING

Air exhausting from one valve into the exhaust gallery of the manifold may pressurize other valve circuits open to the same gallery. Design the circuit such that there is no hazard or damage consequence from this action.

Introduction

Follow these instructions when installing, operating, or servicing the product.

! CAUTION: Solenoid versions of this valve contain solid state components that can be damaged by transient voltage spikes, over-voltage or high temperature. To protect against premature solenoid failure, please read and adhere to the following:

1. If this solenoid operated valve is used in a circuit with other inductive loads. The solenoid should be electrically protected with a voltage suppression device (e.g. transient voltage suppressor or varistor) that has a minimum rating of 1.6 times the rated voltage of the solenoid valve and sufficient capacity to dissipate the energy of other inductive loads.
2. Operating voltage is 90-110% of rated voltage. These limits should not be exceeded.

Application limits, wiring instructions, and instructions for the proper installation of the valves for this manifold are shown in instruction form V360CP, which was shipped with the valve. Service kits and other service instruction sheets are also referenced on this form.

- Manifold End Plate Kit PS2815P
- Common Conduit End Plate Kit PS2822P
- Manifold w/o Flow Control Kit PS2817P
- Manifold w/Flow Control Kit PS2818P

**Assembly Procedure:
Modular Manifold and End Plates**

Notes:

1. Assemblies can be made with or without valves (or inlet block/blanking plates) installed.
2. Valves can be installed in one of two positions on manifolds. It is recommended valves be installed so outlet ports #4 are all in line. When valves are installed on a complete manifold assembly, the port on the end plate marked 5/3 or 3/5 nearest port #4 on the installed valves is port #5. The port on the end plate marked 3/5 or 5/3 nearest port #2 on the installed valve is port #3.
3. If isolator plugs are being used, they should be installed per the instructions on the reverse side while the manifold is being assembled.
4. Manifolds with flow controls should not be used for dual pressure applications.

Assembly:

1. Pre-assemble tie rods (Item #4) into 2 assemblies of equal length. For assemblies of 10 or more manifold bases, it may be necessary to back off one turn between tie rod shoulder-to-shoulder connection in order for tie rod screws to have initial engagement. Thread assemblies into end plate with o-ring grooves (Item #6).
2. Place end plate(s) with threaded assemblies on a flat surface with the o-ring grooves facing up and the tie rod assemblies vertical.
3. Install o-rings (Item #5) into grooves in end plate(s).
4. Slide the first base over the tie rods with its o-ring grooves facing up.
5. Install o-rings into the unit just assembled and repeat the above procedure until all valves are assembled.
6. Assemble the remaining end plate(s) with the flat washers (Item #3), lock washers (Item #2), and tie rod screws (Item #1). Tighten screws to 4.5 to 5.1 N•m (40 to 45 in-lbs) torque using 4mm hex wrench. (It may be beneficial to only snug tie rod screws, place the assembly horizontal, assure squareness, and then finally tighten tie rod screws.)
7. Place assembly horizontal with o-ring grooves facing up. Install larger outside diameter o-rings (Item #9) into center counterbore. Install smaller outside diameter o-rings (Item #8) into two outer counterbores.
8. Place each valve onto its corresponding base and fasten with socket head cap screws (Item #7). Tighten screws to 2.3 to 3.4 N•m (20 to 30 in-lbs) torque using 3mm hex wrench.
9. Make plumbing and electrical connections.
10. Turn on air pressure and electrical power source. Test for proper functional operation and for internal and external air leakage. If leakage is audible (indicating improper assembly is likely), do not operate - conduct assembly again.

! WARNING

FAILURE OR IMPROPER SELECTION OR IMPROPER USE OF THE PRODUCTS AND/OR SYSTEMS DESCRIBED HEREIN OR RELATED ITEMS CAN CAUSE DEATH, PERSONAL INJURY AND PROPERTY DAMAGE.

This document and other information from Parker Hannifin Corporation, its subsidiaries and authorized distributors provide product and/or system options for further investigation by users having technical expertise. It is important that you analyze all aspects of your application, including consequences of any failure and review the information concerning the product or systems in the current product catalog. Due to the variety of operating conditions and applications for these products or systems, the user, through its own analysis and testing, is solely responsible for making the final selection of the products and systems and assuring that all performance, safety and warning requirements of the application are met.

The products described herein, including without limitation, product features, specifications, designs, availability and pricing, are subject to change by Parker Hannifin Corporation and its subsidiaries at any time without notice.

EXTRA COPIES OF THESE INSTRUCTIONS ARE AVAILABLE FOR INCLUSION IN EQUIPMENT / MAINTENANCE MANUALS THAT UTILIZE THESE PRODUCTS. CONTACT YOUR LOCAL REPRESENTATIVE.

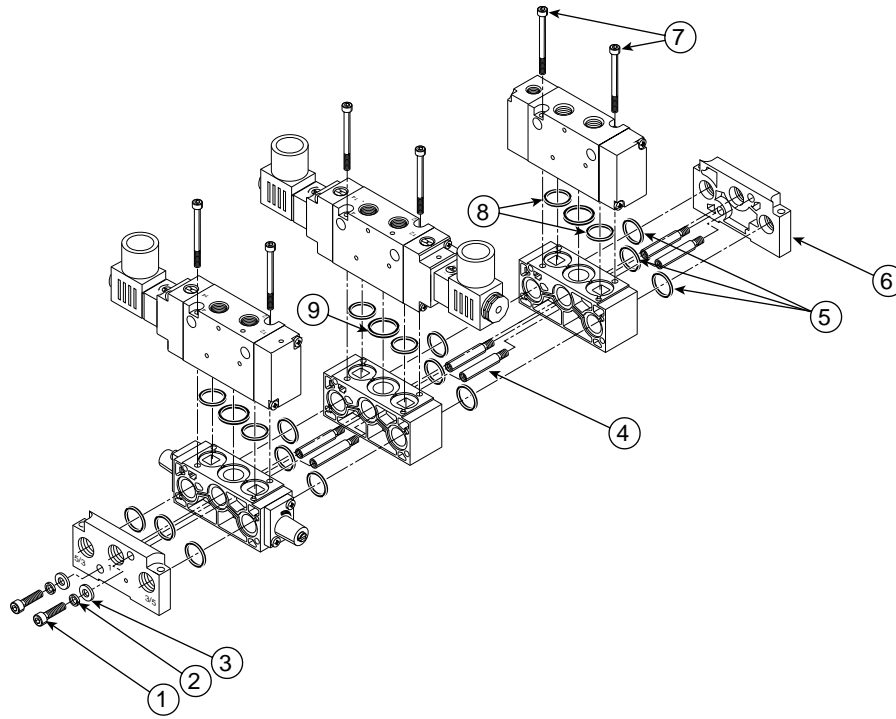

Isolator Plug Kit PS2819P

1. If isolator plugs are to be used in an assembly, they should be installed while the modular manifold is being assembled per the instructions on the reverse side.
2. Each kit contains three (3) plug and o-ring assemblies (Item #10). Plugs may be installed in any one, or all three of the common galleys in the assembly, or any combination thereof. Please consult your specific circuit diagram to determine the proper number and location of plugs to be used. Extra plugs may be discarded.
3. Lightly grease (provided) the plug o-rings and install one end into the proper bore in the manifold. When installing the next manifold base, care should be taken to assure the exposed end of the plug enters the manifold bore without cutting the o-ring.
4. When assembly is complete, turn on air pressure and check for external leakage, as well as leakage across the isolator plug by pressurizing one side and check for leakage at the other side. If leakage is audible (indicating improper assembly is possible), do not operate - perform assembly again.

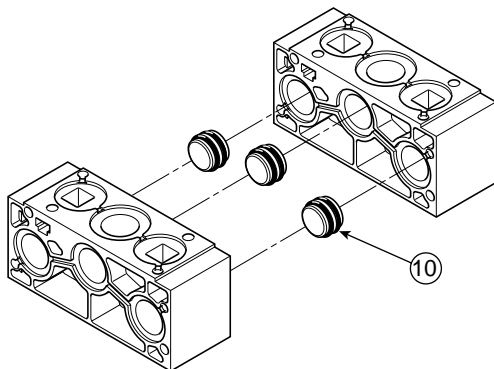

Inlet Block/Blanking Plate Kit- PS2820P

1. Install 3 o-rings (Items #11 & #12), provided with base, into counterbores on top of manifold base. The one larger outside diameter o-ring (Item #12) goes into the center counterbore. The two smaller outside diameter o-rings (Item #11) go into the two outside counterbores.
2. Place flat surface of plate (Item #13) (opposite port countersinks) onto manifold and install two (2) hold down screws (Item #14). Tighten screws to 2.3 to 3.4 N•m (20 to 30 in-lbs) torque using 3mm hex wrench.
3. If being used as a blanking plate, install three (3) pipe plugs (Item #15) into ports.
4. If being used for single pressure intermediate supply, install one pipe plug (Item #15) into two outside ports. Supply connection to common galley #1 is made to center port.
5. If being used for dual pressure intermediate supply, install one (1) pipe plug (item #15) into center port. Supply pressures are supplied to the two outside ports. The higher pressure is to be supplied to the port nearest port #2 on other valves in the assembly.
6. If being used for additional exhaust ports, install one (1) pipe plug (Item #15) into the center port for single pressure systems or two (2) pipe plugs (item #15) into the two outside ports for dual pressure systems.
7. Turn on air pressure and check for leakage. If leakage is audible (indicating improper assembly is likely), do not operate - conduct assembly again.

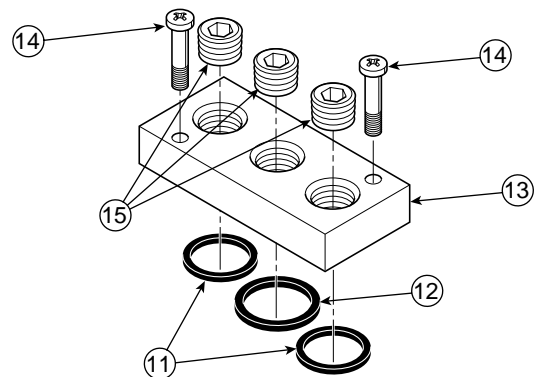



Pneumatic Division
Richland, Michigan 49083

Installation & Service Instructions
V367EP
"B5" Low Watt & Remote Pilot
Series Valves
ISSUED: April, 2011
Supersedes: September, 2006
Doc. # V367P, EN# 110323, Rev. 8

⚠ WARNING

To avoid unpredictable system behavior that can cause personal injury and property damage:

- Disconnect electrical supply (when necessary) before installation, servicing, or conversion.
- Disconnect air supply and depressurize all air lines connected to this product before installation, servicing, or conversion.
- Operate within the manufacturer's specified pressure, temperature, and other conditions listed in these instructions.
- Medium must be moisture-free if ambient temperature is below freezing.
- Service according to procedures listed in these instructions.
- Installation, service, and conversion of these products must be performed by knowledgeable personnel who understand how pneumatic products are to be applied.
- After installation, servicing, or conversion, air and electrical supplies (when necessary) should be connected and the product tested for proper function and leakage. If audible leakage is present, or the product does not operate properly, do not put into use.
- Warnings and specifications on the product should not be covered by paint, etc. If masking is not possible, contact your local representative for replacement labels.

Safety Guide

For more complete information on recommended application guidelines, see the Safety Guide section of Pneumatic Division catalogs or you can download the **Pneumatic Division Safety Guide** at: www.parker.com/safety

Introduction

Follow these instructions when installing, operating, or servicing the product.

Application Limits

These products are intended for use in general purpose compressed air systems only.

General Installation & Operating Instructions

Keep pipe or tubing clean and free of dirt and chips. Pipe joint compound should be used sparingly and applied only to the male pipe - never into the female port. Do not use PTFE tape to seal pipe joints - pieces have a tendency to break off and lodge inside the unit, possibly causing malfunction.

Application Limits (2-Position)

Operating Pressure:

	kPa	PSIG	bar
Minimum	138	20	1.4
Maximum	1030	145	10.0

Application Limits (3-Position)

Operating Pressure:

	kPa	PSIG	bar
Minimum	207	30	2.1
Maximum	1030	145	10.0

NOTE: Solenoid operated valves specified for external pilot or double air pilot operated valves may have pressures down to vacuum in the main valve. External pilot pressure must be greater than or equal to that in the main valve, but not exceed the ranges above.

Ambient Temperature Range: -15°C to 49°C (5°F to 120°F)

Voltage Range: Rated Voltage +10, -15%

⚠ CAUTION: An interruption of 10 milliseconds or greater to the power supplied to the solenoid of a solenoid operated valve may cause the valve to shift. Provision must be made to prevent power interruption of this duration to avoid unintended, potentially hazardous, consequences.

Lubrication

Filtered and lubricated air is necessary for maximum valve life and minimum maintenance. If in-service lubrication is used, lubricate with a straight paraffin based mineral oil having an ISO viscosity grade of 32 (e.g. Sunvis 932).

NOTE: Once in-service lubrication is initiated, the practice should be continued in order to maximize valve life.

Maintenance & Trouble Shooting Hints

Valve Not Shifting Completely When Energized:

1. Check to insure that the proper voltage is supplied to the solenoids.
2. Check to insure that supply pressure is 138 kPa (20 PSIG) or greater at the valve's inlet when shifting valve.
3. Check for possible restrictions in air supply, such as undersized hoses, fittings, or quick disconnects.
4. Check to insure that the spool moves smoothly.
5. Check spool seals for proper installation, dirt, or damage.

⚠ WARNING

FAILURE OR IMPROPER SELECTION OR IMPROPER USE OF THE PRODUCTS AND/OR SYSTEMS DESCRIBED HEREIN OR RELATED ITEMS CAN CAUSE DEATH, PERSONAL INJURY AND PROPERTY DAMAGE.

This document and other information from Parker Hannifin Corporation, its subsidiaries and authorized distributors provide product and/or system options for further investigation by users having technical expertise. It is important that you analyze all aspects of your application, including consequences of any failure and review the information concerning the product or systems in the current product catalog. Due to the variety of operating conditions and applications for these products or systems, the user, through its own analysis and testing, is solely responsible for making the final selection of the products and systems and assuring that all performance, safety and warning requirements of the application are met.

The products described herein, including without limitation, product features, specifications, designs, availability and pricing, are subject to change by Parker Hannifin Corporation and its subsidiaries at any time without notice.

EXTRA COPIES OF THESE INSTRUCTIONS ARE AVAILABLE FOR INCLUSION IN EQUIPMENT / MAINTENANCE MANUALS THAT UTILIZE THESE PRODUCTS. CONTACT YOUR LOCAL REPRESENTATIVE.

Air Leakage Through Exhaust Ports:

1. Check for internal leakage in the cylinder being operated by the valve.
2. Check condition of the spool seals for proper alignment, damaged (nicked or broken) seals and dirt contamination.
3. Check for missing, damaged, or incorrectly assembled o-rings and gaskets.

If installing new spool: Remove old spool assembly, taking care not to scratch bore. Install new spool assembly into clean bore, taking care to install squarely and push slowly to avoid damaging seals or the valve bore.

If installing new piston: Refer to drawing for proper orientation. Install piston/seal assembly into the operator bore, taking care to assure the lips of the seal pass smoothly into the bore.

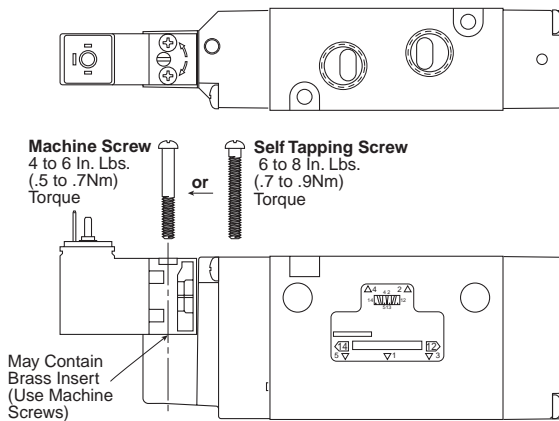

- ① Lightly grease with provided lubricant.
- ✓ Inspect for nicks, scratches, and surface imperfections. If present, reduced service life is probable and future replacement should be planned.
- Ⓒ Clean with lint-free cloth.
- * If more aggressive cleaning is required, use mineral spirits or equivalent solvent and dry thoroughly.

The Following Service Kits & Accessories are available:

- PS2801P** 2-Position Body Service Kit
Contains 1 of items D & J, and 2 of items F & C.
- PS2803P** 3 Position Cylinder to Exhaust Body Service Kit
Contains 1 of item J, 2 of item C, and 2 ea. of item F.
- PS2804P** 3 Position Pressure Center Body Service Kit
Contains 1 of item J, 2 of item C, and 2 ea. of item F.
- PS2982*XXP** Solenoid Service Kits
Contains 1 of item A

- *, Override = B (Non-locking, flush)
C (Locking, flush)
D (Non-locking, extended)
E (Locking, extended)

- XX, Voltage code = 42 (24 VAC)
45 (12 VDC)
49 (24 VDC)
53 (120 VAC)
57 (240 VAC)

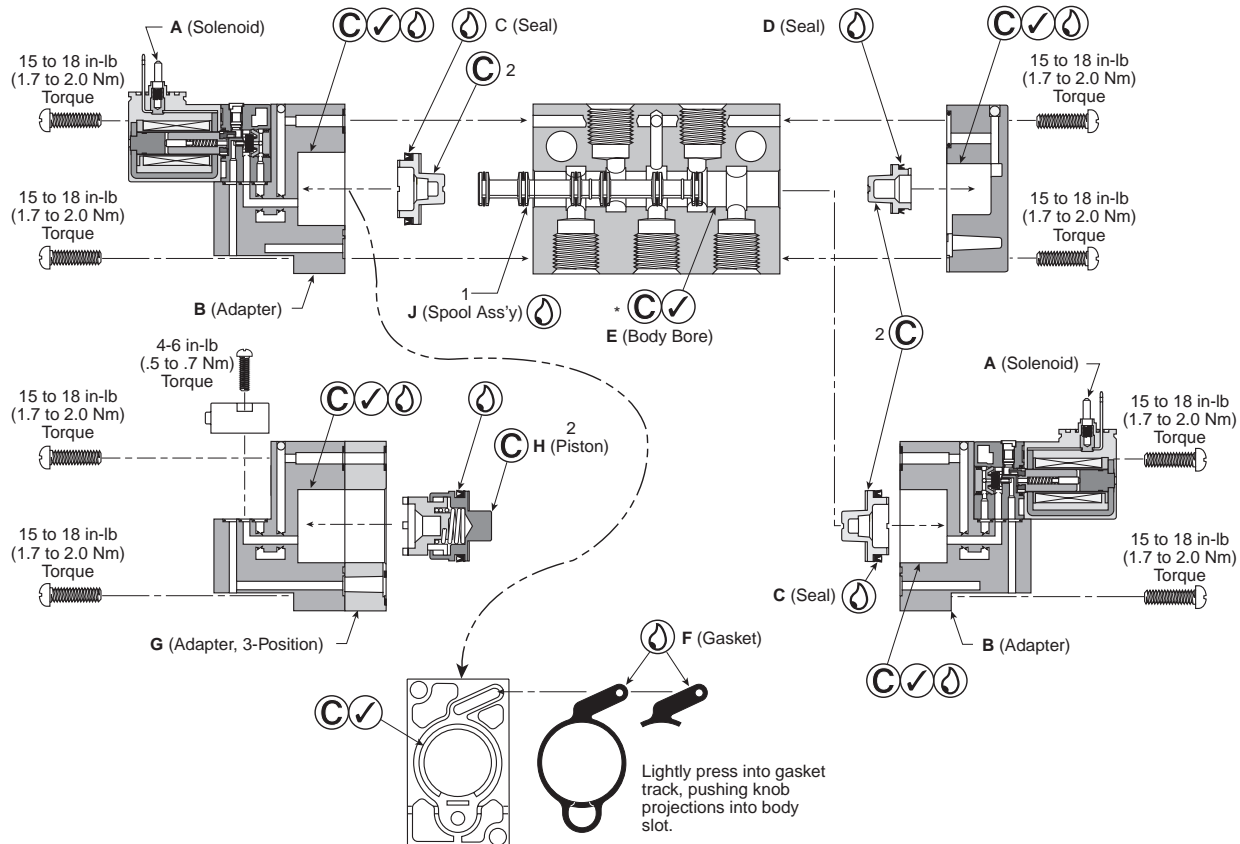



Pneumatic Division
Richland, Michigan 49083

Installation & Service Instructions:
V374EP
"B3" Series Valve, Modular Manifold,
4-Way & 3-Way
ISSUED: September, 2006
Supersedes: October, 2003
Doc# V-374P, ECN# 060870, Rev. 8

⚠ WARNING

To avoid unpredictable system behavior that can cause personal injury and property damage:

- Disconnect electrical supply (when necessary) before installation, servicing, or conversion.
- Disconnect air supply and depressurize all air lines connected to this product before installation, servicing, or conversion.
- Operate within the manufacturer's specified pressure, temperature, and other conditions listed in these instructions.
- Medium must be moisture-free if ambient temperature is below freezing.
- Service according to procedures listed in these instructions.
- Installation, service, and conversion of these products must be performed by knowledgeable personnel who understand how pneumatic products are to be applied.
- After installation, servicing, or conversion, air and electrical supplies (when necessary) should be connected and the product tested for proper function and leakage. If audible leakage is present, or the product does not operate properly, do not put into use.
- Warnings and specifications on the product should not be covered by paint, etc. If masking is not possible, contact your local representative for replacement labels.

Safety Guide

For more complete information on recommended application guidelines, see the Safety Guide section of Pneumatic Division catalogs or you can download the **Pneumatic Division Safety Guide** at: www.parker.com/safety

Introduction

Follow these instructions, the unit's application limits, wiring instructions, and instructions for the proper installation of the valves for this manifold as shown in instruction form V-400BP, which was shipped with the valve. Service kits and other service instruction sheets are also referenced on this form. Copies of instruction form V-400BP are available from your local representative.

- Manifold End Plate Kit: 4-Way valvesPS2915P
- Manifold w/o Flow Control Kit: 4-Way valvesPS2917P
- Manifold w/Flow Control Kit: 4-Way valvesPS2918P
- Manifold End Plate Kit: 3-Way valvesPS2950P
- Manifold w/o Flow Control Kit: 3-Way valvesPS2948P
- Manifold w/Flow Control Kit: 3-Way valvesPS2949P

Assembly Procedure:
Modular Manifold and End Plates

Notes:

1. Assemblies can be made with or without valves (or inlet block / blanking plates) installed. Assembly is easier if valves are installed after the manifold is assembled.
2. **4-Way Valves:** (See Figure 1)
Valves can be installed in one of two positions on manifolds. It is recommended that valves be installed so outlet ports #4 are all in line. When valves are installed on a complete manifold assembly, the port on the end plate marked 5/3 or 3/5 nearest port #4 on the installed valves is port #5. The port on the end plate marked 3/5 or 5/3 nearest port #2 on the installed valve is port #3.

3-Way Valves: (See Figure 2)

Install valves so that the port designated as #1 on the valve body is closest to the port designated as #1 on the manifold end plate.

3. If isolator plugs are being used, they should be installed per the isolator plug kit instructions while the manifold is being assembled.
4. Manifolds with flow controls should not be used for dual pressure applications.

Assembly:

1. Preassemble tie rods (Item #72) into assemblies of equal length. For assemblies of 10 or more manifold bases, it may be necessary to back off one turn between tie rod shoulder-to-shoulder connection in order for tie rod screws to have initial engagement. Thread assemblies into end plate with o-ring grooves (Item #77).
2. Place end plate(s) with threaded assemblies on a flat surface with the o-ring grooves facing up and the tie rod assemblies vertical.
3. Install o-rings (Item #88) into grooves in end plate and at each port between manifolds.
4. Slide the first base over the tie rods with its gasket track facing up.
5. Install molded gasket (Item #103) into the unit just assembled and repeat the above procedure until all bases are assembled.
6. Assemble the remaining end plate (Item #76) with the flat washers (Item #87), lock washers (Item #86), and tie rod screws (Item #85). Tighten screws from 1.7 to 2.3 Nm (15 to 20 in-lbs) torque using 2.5mm hex wrench. (It may be beneficial to only snug tie rod screws, place the assembly horizontal, assure squareness, and then finally tighten tie rod screws.)
7. Place assembly horizontal with gasket track facing up. Install molded gaskets (Item #102) into tracks.
8. Place each valve onto its corresponding base and fasten with socket head cap screws (Item #84). Tighten screws to 1.1 Nm (10 in-lbs) torque using 2.5mm hex wrench.

⚠ WARNING

FAILURE OR IMPROPER SELECTION OR IMPROPER USE OF THE PRODUCTS AND/OR SYSTEMS DESCRIBED HEREIN OR RELATED ITEMS CAN CAUSE DEATH, PERSONAL INJURY AND PROPERTY DAMAGE.

This document and other information from Parker Hannifin Corporation, its subsidiaries and authorized distributors provide product and/or system options for further investigation by users having technical expertise. It is important that you analyze all aspects of your application, including consequences of any failure and review the information concerning the product or systems in the current product catalog. Due to the variety of operating conditions and applications for these products or systems, the user, through its own analysis and testing, is solely responsible for making the final selection of the products and systems and assuring that all performance, safety and warning requirements of the application are met.

The products described herein, including without limitation, product features, specifications, designs, availability and pricing, are subject to change by Parker Hannifin Corporation and its subsidiaries at any time without notice.

EXTRA COPIES OF THESE INSTRUCTIONS ARE AVAILABLE FOR INCLUSION IN EQUIPMENT / MAINTENANCE MANUALS THAT UTILIZE THESE PRODUCTS. CONTACT YOUR LOCAL REPRESENTATIVE.

"B3" Series Valve, Modular Manifold, 4-Way & 3-Way

V-374EP

9. Make plumbing and electrical connections.
10. Turn on air pressure and electrical power source. Test for proper functional operation and for internal and external air leakage. If leakage is audible (indicating improper assembly is likely), do not operate - conduct assembly again.

Isolator Plug Kit - PS2919P - 4-Way Valves PS291901P - 3-Way Valves

(See Figure 3)

1. If isolator plugs are to be used in an assembly, they should be installed while the modular manifold is being assembled.
2. Each kit contains three plug and o-ring assemblies (Item #90). Plugs may be installed in any one, or all of the common galleries in the assembly, or any combination thereof. Please consult your specific circuit diagram to determine the proper number and location of plugs to be used. Extra plugs may be discarded.
3. Lightly grease (supplied with kit) the plug o-rings and install one end into the proper bore in the manifold. When installing the next manifold base, care should be taken to assure that the exposed end of the plug enters the manifold bore without cutting the o-ring.
4. When assembly is complete, turn on air pressure and check for external leakage, as well as leakage across the isolator plug by pressurizing one side and check for leakage at the other side. If leakage is audible (indicating improper assembly is possible), do not operate - perform assembly again.

Inlet Block / Blanking Plate Kit - PS2920P - 4-Way Valves PS2966P - 3-Way Valves

(See Figure 4)

1. Install molded seal (Item #102), provided with base, into track on top of manifold base.
2. Place flat surface of plate (Item #92) (opposite port countersinks) onto manifold and install two hold down screws (Item #93). Tighten screws to 1.1 Nm (10 in-lbs) torque using 2.5mm hex wrench.

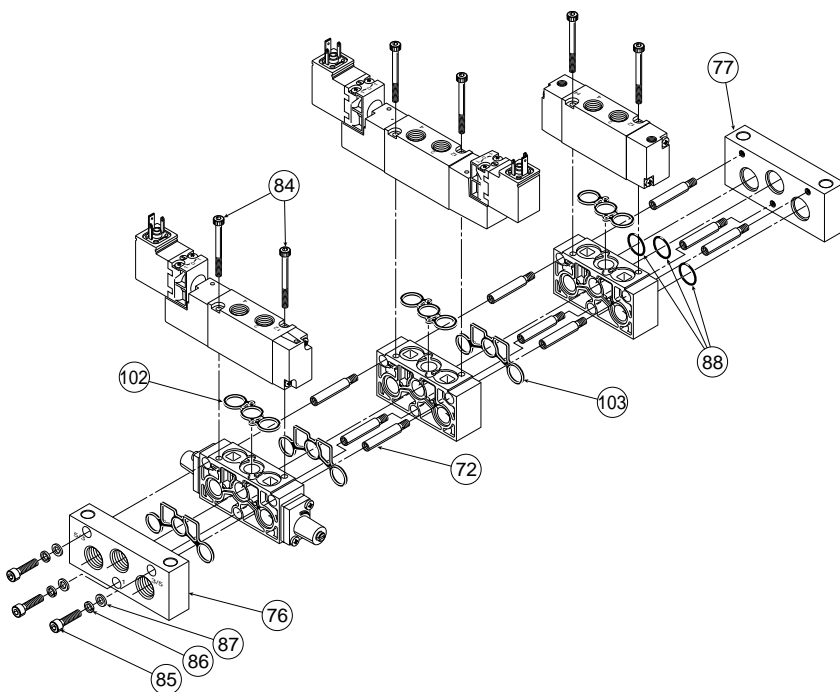

Figure 1:
4-Way Valve Manifolds

3. If being used as a blanking plate, install pipe plug (Item #94) into each port.

4. If being used for single pressure intermediate supply,

4-Way Valves:

Install two pipe plugs (Item #94) into two outside ports. Supply connection to common galley #1 is made to center port.

3-Way Valves:

Install pipe plug (Item #94) into port #3. Connect supply to port #1.

5. 4-Way Valves:

If being used for dual pressure intermediate supply, install one pipe plug (Item #94) into center port. Supply pressures are supplied to the two outside ports. The higher pressure is to be supplied to the port nearest port #2 on other valves in the assembly.

6. If being used for additional exhaust ports,

4-Way Valves:

Install one pipe plug (Item #94) into the center port for single pressure systems or two pipe plugs (Item #94) into the two outside ports for dual pressure systems.

3-Way Valves:

Install pipe plug (Item #94) into port #1

7. Turn on air pressure and check for leakage. If leakage is audible (indicating improper assembly is likely), do not operate - conduct assembly again.

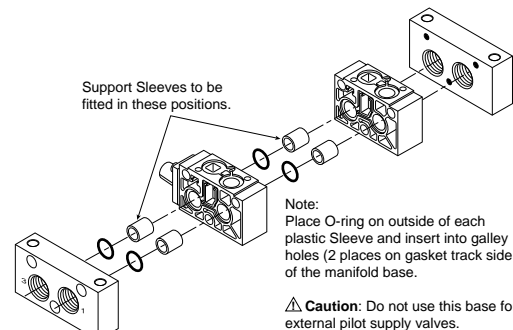

Figure 2:
3-Way Valve Manifolds

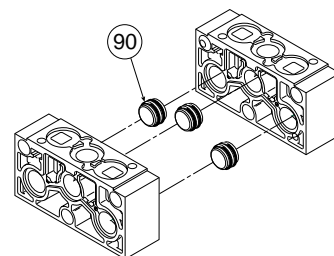

Figure 3:
4-Way Valve Manifold Is Shown

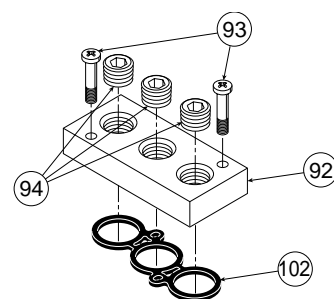

Figure 4:
4-Way Valve Plate Is Shown



Pneumatic Division North America
 Richland, Michigan 49083

Installation & Service Instructions
V-375BP

B3 Sandwich Regulator

ISSUED: February, 2003
Supersedes: August, 2000

ECN# 030108

⚠ WARNING

To avoid unpredictable system behavior that can cause personal injury and property damage:

- Disconnect electrical supply (when necessary) before installation, servicing, or conversion.
- Disconnect air supply and depressurize all air lines connected to this product before installation, servicing, or conversion.
- Operate within the manufacturer's specified pressure, temperature, and other conditions listed in these instructions.
- Medium must be moisture-free if ambient temperature is below freezing.
- Service according to procedures listed in these instructions.
- Installation, service, and conversion of these products must be performed by knowledgeable personnel who understand how pneumatic products are to be applied.
- After installation, servicing, or conversion, air and electrical supplies (when necessary) should be connected and the product tested for proper function and leakage. If audible leakage is present, or the product does not operate properly, do not put into use.
- Warnings and specifications on the product should not be covered by paint, etc. If masking is not possible, contact your local representative for replacement labels.

Introduction:

Follow these instructions when installing, operating, or servicing the product.

Application Limits:

These products are intended for use in general purpose compressed air systems only.

Operating Inlet Pressure:	kPa	psig	bar
Maximum	1034	150	10.34

Ambient Temperature Range: 0°C to 52°C (32°F to 125°F)

Voltage Range: +10 to -15% of rating
 (Applicable only for solenoid operated valves)

NOTE: Some of the above ratings are those of the associated valve.

Common Port Regulator with 4-Way, 2-Position Valve

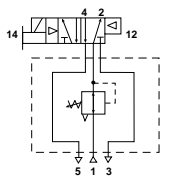

Independent Port Regulator with 4-Way, 3-Position All Ports Blocked Valve

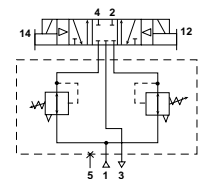

Independent Port Regulator with 4-Way, 3-Position, Inlet to Cylinder Function

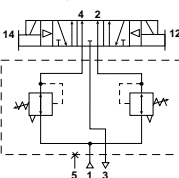

⚠ CAUTION: Requires 4-Way, 3-Position, Cylinder to Exhaust Valve

Independent Port Regulator with 4-Way, 3-Position, Cylinder to Exhaust Function

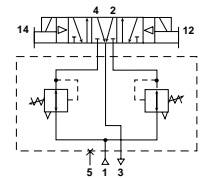

⚠ CAUTION: Requires 4-Way, 3-Position, Inlet to Cylinder Valve

* Marfak MP-2 is a registered trademark of Texaco.

Installation & Operating Instructions:

A sandwich regulator is used to provide regulated pressure to individual valves in a manifolded valve arrangement. Two basic modes of regulation are available as follows:

Common Port Regulation - Provides adjustable regulated air pressure to the valve inlet.

Independent Port Regulation - Provides (2) separately adjustable regulated air pressures, one to each of the valves exhaust passages. The valves exhaust (coming out of its inlet passage) is directed to manifold or subbase exhaust port "3"

⚠ **CAUTION:** The reverse valve porting utilized with Independent Port Regulation will reverse the function of 4-Way, 3-Position cylinder to exhaust and 4-Way, 3-Position inlet to cylinder valves. Utilize the opposite function valve for normal operation.

Sandwich regulator should be installed with reasonable accessibility for service whenever possible. Repair service kits are available. Keep pipe or tubing lengths to a minimum with inside clean and free of dirt and chips. Pipe joint compound should be used sparingly and applied only to the male pipe, never into the female port. Do not use PTFE tape to seal pipe joints. Pieces have a tendency to break off and lodge inside the unit, possibly causing malfunction.

Air applied to the sandwich regulator must be filtered to realize maximum component life.

Factory Pre-Lubrication - Sandwich regulators are pre-lubricated at assembly with Marfak MP-2* grease.

⚠ **CAUTION:** Do not use synthetic, reconstituted, or oils with an alcohol content or detergent additive.

⚠ WARNING

FAILURE OR IMPROPER SELECTION OR IMPROPER USE OF THE PRODUCTS AND/OR SYSTEMS DESCRIBED HEREIN OR RELATED ITEMS CAN CAUSE DEATH, PERSONAL INJURY AND PROPERTY DAMAGE.

This document and other information from Parker Hannifin Corporation, its subsidiaries and authorized distributors provide product and/or system options for further investigation by users having technical expertise. It is important that you analyze all aspects of your application, including consequences of any failure and review the information concerning the product or systems in the current product catalog. Due to the variety of operating conditions and applications for these products or systems, the user, through its own analysis and testing, is solely responsible for making the final selection of the products and systems and assuring that all performance, safety and warning requirements of the application are met.

The products described herein, including without limitation, product features, specifications, designs, availability and pricing, are subject to change by Parker Hannifin Corporation and its subsidiaries at any time without notice.

EXTRA COPIES OF THESE INSTRUCTIONS ARE AVAILABLE FOR INCLUSION IN EQUIPMENT / MAINTENANCE MANUALS THAT UTILIZE THESE PRODUCTS. CONTACT YOUR LOCAL REPRESENTATIVE.

Installation:

1. Place Sandwich Regulator on top of the subbase or manifold making sure that the tabs of the gasket are installed into the appropriate holes.
2. Place valve on top of Sandwich Regulator lining up tabs of the gasket to location holes in the Sandwich Regulator.
3. Assemble valve and sandwich regulator with (2) mounting screws. Tighten screws to 1.7 Nm (15 in-lb) torque using 2.5mm hex wrench.
4. Apply pressure to subbase or manifold and check for audible leakage at joints. If any are present, do not operate the valve. Repeat the assembly procedure until satisfied.
5. Adjust outlet pressure per *Outlet Pressure Adjustment* procedure to verify proper function.

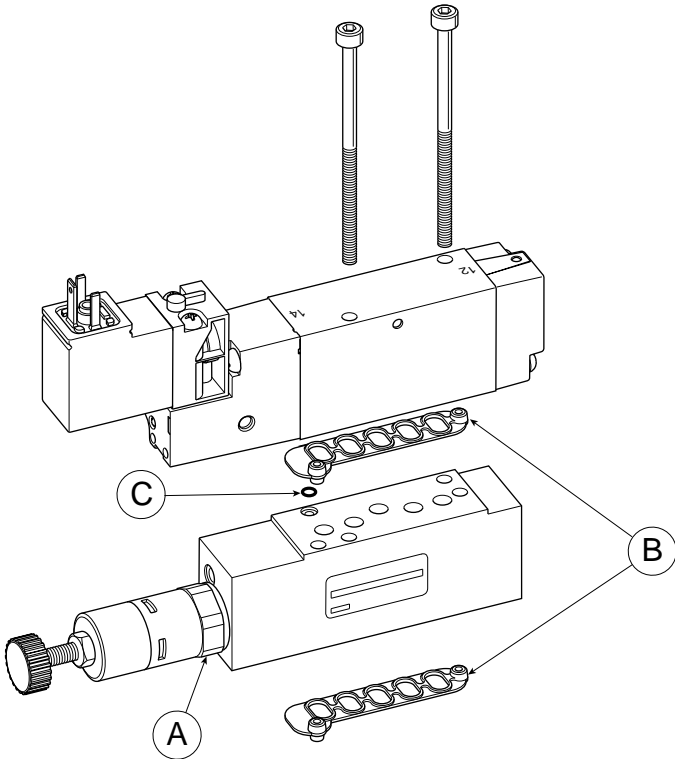

Outlet Pressure Adjustment:

1. Before turning on the air supply, turn the adjusting knob counterclockwise until compression is released from the pressure control spring then turn on air supply. Proceed to adjust the desired downstream pressure by turning adjusting knob clockwise. This permits pressure to build up slowly in the downstream line.
2. To decrease regulated pressure setting, always reset from a pressure lower than the final setting required. Example, lowering the secondary pressure from 550 kPa (80 PSIG) to 410 kPa (60 PSIG) is best accomplished by dropping the secondary pressure to 345 kPa (50 PSIG), then adjusting upward to 410 kPa (60 PSIG).

Service Instructions:

1. Disconnect air supply and depressurize the unit.
2. Loosen nut on adjusting screw. Turn adjusting screw counterclockwise until all downstream air is exhausted.
3. Remove regulator cartridge from block and replace with a new unit.
4. Reapply pressure to unit and check for audible leakage at joints or out bleed holes. If any are present, do not operate the valve. Repeat assembly procedure until satisfied.
5. Adjust outlet pressure per *Outlet Pressure Adjustment* procedure.

Replacement Parts:

Item No.	Part Number	Description
A	PS299922P PS299933P	Regular cartridge, 60 PSI Regular cartridge, 125 PSI
B	P02465	Gasket, body/base
C	K41RB75051	O-Ring, body/regulator

Replacement Gauge:

PSI	Standard
0 - 160	P53451160P

 **WARNING**

To avoid unpredictable system behavior that can cause personal injury and property damage:

- Disconnect electrical supply (when necessary) before installation, servicing, or conversion.
- Disconnect air supply and depressurize all air lines connected to this product before installation, servicing, or conversion.
- Operate within the manufacturer's specified pressure, temperature, and other conditions listed in these instructions.
- Medium must be moisture-free if ambient temperature is below freezing.
- Service according to procedures listed in these instructions.
- Installation, service, and conversion of these products must be performed by knowledgeable personnel who understand how pneumatic products are to be applied.
- After installation, servicing, or conversion, air and electrical supplies (when necessary) should be connected and the product tested for proper function and leakage. If audible leakage is present, or the product does not operate properly, do not put into use.
- Warnings and specifications on the product should not be covered by paint, etc. If masking is not possible, contact your local representative for replacement labels.

 **WARNING**

FAILURE OR IMPROPER SELECTION OR IMPROPER USE OF THE PRODUCTS AND/OR SYSTEMS DESCRIBED HEREIN OR RELATED ITEMS CAN CAUSE DEATH, PERSONAL INJURY AND PROPERTY DAMAGE.

This document and other information from Parker Hannifin Corporation, its subsidiaries and authorized distributors provide product and/or system options for further investigation by users having technical expertise. It is important that you analyze all aspects of your application, including consequences of any failure and review the information concerning the product or systems in the current product catalog. Due to the variety of operating conditions and applications for these products or systems, the user, through its own analysis and testing, is solely responsible for making the final selection of the products and systems and assuring that all performance, safety and warning requirements of the application are met.

The products described herein, including without limitation, product features, specifications, designs, availability and pricing, are subject to change by Parker Hannifin Corporation and its subsidiaries at any time without notice.

EXTRA COPIES OF THESE INSTRUCTIONS ARE AVAILABLE FOR INCLUSION IN EQUIPMENT / MAINTENANCE MANUALS THAT UTILIZE THESE PRODUCTS. CONTACT YOUR LOCAL REPRESENTATIVE.

 **WARNING**

Air exhausting from one valve into the exhaust gallery of the manifold assembly may momentarily pressurize other valve circuits open to the same gallery. Design the circuit such that there is no hazard or consequence of damage from this action.

Safety Guide

For more complete information on recommended application guidelines, see the Safety Guide section of Pneumatic Division catalogs or you can download the **Pneumatic Division Safety Guide** at: www.parker.com/safety

Application limits, wiring instructions, and instructions for the proper installation of the valves for this manifold are shown in instruction form V-360P for B5, which was shipped with the valve. Service kits and other service instruction sheets are also referenced on this form. Copies of instruction forms V-360P are available from your local representative.

Assembly Procedure:
Notes:

1. For 4-Way valves, it is recommended valves be installed so outlet ports #4 are all in line. When externally piloted 4-Way valves are installed on the manifold, the Port 4 on the valve must be nearest Port 5 on the manifold. For 3-Way valves, the Port 1 on the valve must line up with Port 1 on the manifold.
2. 4-Way manifolds with flow controls should not be used for dual pressure applications.

Assembly: (See Figure 1)

1. Place bar manifold horizontal with o-ring grooves facing up. For 4-Way manifolds, install larger outside diameter o-rings (Item #89) into center counterbore. Install smaller outside diameter o-rings (Item #88) into two outer counterbores. For 3-Way manifolds, install the two equal size o-rings into the two counterbores on top. For externally piloted valves through the manifold, install the small o-ring provided (Item #90) in the small counterbore on top of the manifold. Manifolds equipped with flow controls are shipped with the flow control assembly pre-assembled to the manifold.
2. Place each valve at its corresponding location and fasten with socket head cap screws (Item #84). Tighten screws to 1.7 to 2.3 Nm (15 to 20 in. lb.) torque using 3mm hex wrench.
3. Make plumbing and electrical connections.
4. Turn on air pressure and electrical power source. Test for proper functional operation and for internal and external air leakage. If leakage is audible (indicating improper assembly is likely), do not operate - conduct assembly again.

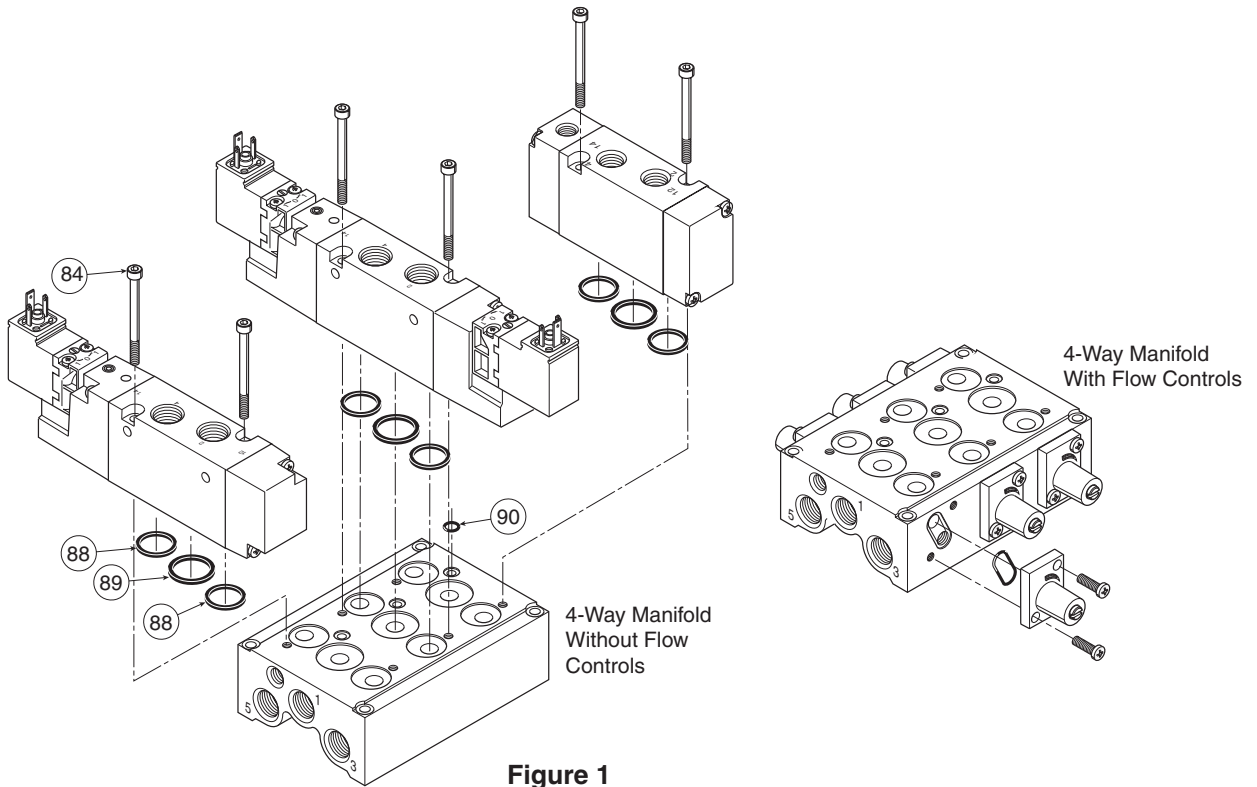

Figure 1

Inlet Block / Blanking Plate Kit

- B5 - 4-Way.....PS2820P**
- 3-Way.....PS2866P**

1. For 4-Way valves, install 3 o-rings provided in kits PS2820P (Items #88 & #89), provided with base, into counterbores on top of manifold base. The one larger outside diameter o-ring (Item #89) goes into the center counterbore. The two smaller outside diameter o-rings (Item #88) go into the two outside counterbores. For 3-Way valves, install the two o-rings provided in kits PS2866P.
2. Place flat surface of plate (Item #92) (opposite port countersinks) onto manifold and install two (2) hold down screws (Item #93). Tighten screws to 1.7 to 2.3 Nm (15 to 20 in-lb) torque using 3mm hex wrench.
3. If being used as a blanking plate, install three (3) pipe plugs (Item #94) into ports.

4. For 4-Way valves only: if being used for single pressure intermediate supply, install pipe plugs (Item #94) into two outside ports. Supply connection to common galley #1 is made to center port.
5. For 4-Way valves only: if being used for dual pressure intermediate supply, install one pipe plug (Item #94) into center port. Supply pressures are supplied to the two outside ports. The higher pressure is to be supplied to the port nearest port #2 on other valves in the assembly.
6. For 4-Way valves only: if being used for additional exhaust ports, install one (1) pipe plug (Item #94) into the center port for single pressure systems or two (2) pipe plugs (Item #94) into the two outside ports for dual pressure systems.
7. Turn on air pressure and check for leakage. If leakage is audible (indicating improper assembly is likely), do not operate - conduct assembly again.

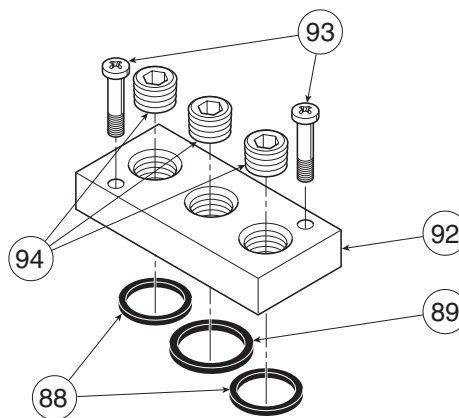

B5 Shown



Pneumatic Division North America
 Richland, Michigan 49083

Installation & Service Instructions:
 V-377P

**B3 Valve to Slideair Valve Manifold
 Transition Plate**

ISSUED: March, 2000
Supersedes: None

NPR# 6928

! WARNING

To avoid unpredictable system behavior that can cause personal injury and property damage:

- Disconnect electrical supply (when necessary) before installation, servicing, or conversion.
- Disconnect air supply and depressurize all air lines connected to this product before installation, servicing, or conversion.
- Operate within the manufacturer's specified pressure, temperature, and other conditions listed in these instructions.
- Medium must be moisture-free if ambient temperature is below freezing.
- Service according to procedures listed in these instructions.
- Installation, service, and conversion of these products must be performed by knowledgeable personnel who understand how pneumatic products are to be applied.
- After installation, servicing, or conversion, air and electrical supplies (when necessary) should be connected and the product tested for proper function and leakage. If audible leakage is present, or the product does not operate properly, do not put into use.
- Warnings and specifications on the product should not be covered by paint, etc. If masking is not possible, contact your local representative for replacement labels.

Introduction

Follow these instructions when installing, operating, or servicing the product.

Application Limits

These products are intended for use in general purpose compressed air systems only.

Operating Inlet Pressure:

	kPa	psig	bar
Min.	140	20	1.4
Max.	689	100	6.8

NOTE: Solenoid operated valves, when specified with external pilot, may have operating pressures down to vacuum in the main valve. External pilot pressure and air pilot signals must be greater than or equal to that in the main valve, but not outside the ratings above.

Ambient Temperature Range: 0°C to 50°C (32°F to 120°F)

Voltage Range: Rated Voltage +10%, -15%

Installation Instructions (See Figure 1)

1. Remove Slideair Valve and o-ring seals from manifold and discard. Lightly lubricate (2) o-rings (A) and o-ring (B) and place them in their recessed locations on the manifold body. NOTE: O-ring (B) is slightly larger than o-ring (E).
2. Assemble bottom plate (C) to manifold using phillips head screws (D). Torque to .56 to .64 Nm (80 to 90 in. ozs.)
3. Lightly lubricate (2) o-rings (A) and o-ring (E) and assemble to counterbores in underside of top plate (F). Place top plate (F) on bottom plate (C) orienting to center screw locations. Assemble screws (G) and torque to 1.7Nm (240 in.ozs.).
4. Lubricate lightly (3) remaining o-rings (E) and assemble to counterbores in top plate (F).
5. Fasten B3 valve down using (2) mounting screws (H) included in kit. Tighten to 1.7 Nm (240 in. ozs.) torque.

6. Plumb the valve according to Installation Instructions that came with the valve. Apply air pressure and check assembly for leakage.

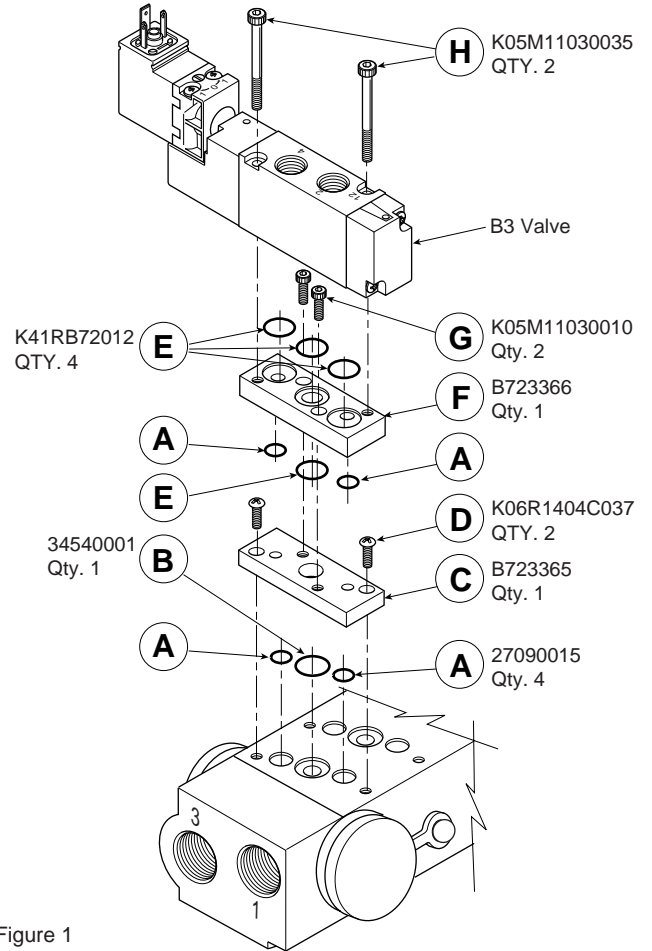

Figure 1

! WARNING

FAILURE OR IMPROPER SELECTION OR IMPROPER USE OF THE PRODUCTS AND/OR SYSTEMS DESCRIBED HEREIN OR RELATED ITEMS CAN CAUSE DEATH, PERSONAL INJURY AND PROPERTY DAMAGE.

This document and other information from Parker Hannifin Corporation, its subsidiaries and authorized distributors provide product and/or system options for further investigation by users having technical expertise. It is important that you analyze all aspects of your application, including consequences of any failure and review the information concerning the product or systems in the current product catalog. Due to the variety of operating conditions and applications for these products or systems, the user, through its own analysis and testing, is solely responsible for making the final selection of the products and systems and assuring that all performance, safety and warning requirements of the application are met.

The products described herein, including without limitation, product features, specifications, designs, availability and pricing, are subject to change by Parker Hannifin Corporation and its subsidiaries at any time without notice.

EXTRA COPIES OF THESE INSTRUCTIONS ARE AVAILABLE FOR INCLUSION IN EQUIPMENT / MAINTENANCE MANUALS THAT UTILIZE THESE PRODUCTS. CONTACT YOUR LOCAL REPRESENTATIVE.



Pneumatic Division
Richland, Michigan 49083

Assembly Procedure: V-378BP

“B4” & “B5” Series Valve
Extruded Manifold

ISSUED: June, 2001

Supersedes: April, 1998

ECN# P28319

 **WARNING**

To avoid unpredictable system behavior that can cause personal injury and property damage:

- Disconnect electrical supply (when necessary) before installation, servicing, or conversion.
- Disconnect air supply and depressurize all air lines connected to this product before installation, servicing, or conversion.
- Operate within the manufacturer’s specified pressure, temperature, and other conditions listed in these instructions.
- Medium must be moisture-free if ambient temperature is below freezing.
- Service according to procedures listed in these instructions.
- Installation, service, and conversion of these products must be performed by knowledgeable personnel who understand how pneumatic products are to be applied.
- After installation, servicing, or conversion, air and electrical supplies (when necessary) should be connected and the product tested for proper function and leakage. If audible leakage is present, or the product does not operate properly, do not put into use.
- Warnings and specifications on the product should not be covered by paint, etc. If masking is not possible, contact your local representative for replacement labels.

 **WARNING**

Air exhausting from one valve into the exhaust gallery of the manifold may pressurize other valve circuits open to the same gallery. Design the circuit such that there is no hazard or damage consequence from this action.

Application limits, wiring instructions, and instructions for the proper installation of the valves for this manifold are shown in instruction form V-360P for B5, V-355P for B4, which was shipped with the valve. Service kits and other service instruction sheets are also referenced on this form. Copies of instruction forms V-360P and V-355P are available from your local representative.

Assembly Procedure:

Notes:

1. For 4-Way valves, it is recommended valves be installed so outlet ports #4 are all in line. When externally piloted 4-Way valves are installed on the manifold, the Port 4 on the valve must be nearest Port 5 on the manifold. For 3-Way valves, the Port 1 on the valve must line up with Port 1 on the manifold.
2. 4-Way manifolds with flow controls should not be used for dual pressure applications.

Assembly: (See Figure 1)

1. Place bar manifold horizontal with o-ring grooves facing up. For 4-Way manifolds, install larger outside diameter o-rings (Item #89) into center counterbore. Install smaller outside diameter o-rings (Item #88) into two outer

counterbores. For 3-Way manifolds, install the two equal size o-rings into the two counterbores on top. For externally piloted valves through the manifold, install the small o-ring provided (Item #90) in the small counterbore on top of the manifold. Manifolds equipped with flow controls are shipped with the flow control assembly pre-assembled to the manifold.

2. Place each valve at its corresponding location and fasten with socket head cap screws (Item #84). Tighten screws to 1.7 to 2.3 Nm (15 to 20 in. lb.) torque using 3mm hex wrench.
3. Make plumbing and electrical connections.
4. Turn on air pressure and electrical power source. Test for proper functional operation and for internal and external air leakage. If leakage is audible (indicating improper assembly is likely), do not operate - conduct assembly again.

 **WARNING**

FAILURE OR IMPROPER SELECTION OR IMPROPER USE OF THE PRODUCTS AND/OR SYSTEMS DESCRIBED HEREIN OR RELATED ITEMS CAN CAUSE DEATH, PERSONAL INJURY AND PROPERTY DAMAGE.

This document and other information from Parker Hannifin Corporation, its subsidiaries and authorized distributors provide product and/or system options for further investigation by users having technical expertise. It is important that you analyze all aspects of your application, including consequences of any failure and review the information concerning the product or systems in the current product catalog. Due to the variety of operating conditions and applications for these products or systems, the user, through its own analysis and testing, is solely responsible for making the final selection of the products and systems and assuring that all performance, safety and warning requirements of the application are met.

The products described herein, including without limitation, product features, specifications, designs, availability and pricing, are subject to change by Parker Hannifin Corporation and its subsidiaries at any time without notice.

EXTRA COPIES OF THESE INSTRUCTIONS ARE AVAILABLE FOR INCLUSION IN EQUIPMENT / MAINTENANCE MANUALS THAT UTILIZE THESE PRODUCTS. CONTACT YOUR LOCAL REPRESENTATIVE.

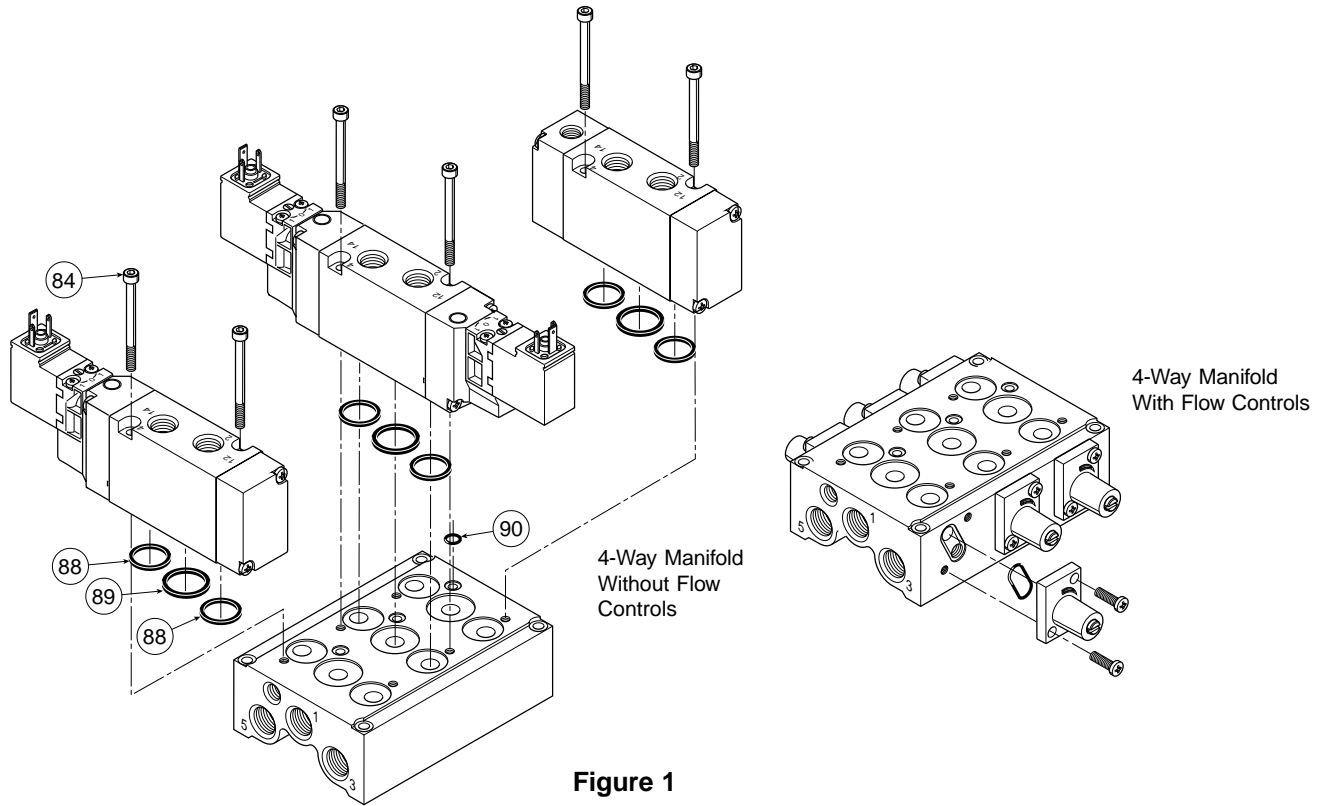

Figure 1

Inlet Block / Blanking Plate Kit

B5 - 4-Way	PS2820P
3-Way	PS2866P
B4 - 4-Way	PS4520P
3-Way	PS4566P

- For 4-Way valves, install 3 o-rings provided in kits PS2820P & PS4520P (Items #88 & #89), provided with base, into counterbores on top of manifold base. The one larger outside diameter o-ring (Item #89) goes into the center counterbore. The two smaller outside diameter o-rings (Item #88) go into the two outside counterbores. For 3-Way valves, install the two o-rings provided in kits PS2866P & PS4566P.
- Place flat surface of plate (Item #92) (opposite port countersinks) onto manifold and install two (2) hold down screws (Item #93). Tighten screws to 1.7 to 2.3 N•m (15 to 20 in-lb) torque using 3mm hex wrench.

- If being used as a blanking plate, install three (3) pipe plugs (Item #94) into ports.
- For 4-Way valves only: if being used for single pressure intermediate supply, install pipe plugs (Item #94) into two outside ports. Supply connection to common galley #1 is made to center port.
- For 4-Way valves only: if being used for dual pressure intermediate supply, install one pipe plug (Item #94) into center port. Supply pressures are supplied to the two outside ports. The higher pressure is to be supplied to the port nearest port #2 on other valves in the assembly.
- For 4-Way valves only: if being used for additional exhaust ports, install one (1) pipe plug (Item #94) into the center port for single pressure systems or two (2) pipe plugs (Item #94) into the two outside ports for dual pressure systems.
- Turn on air pressure and check for leakage. If leakage is audible (indicating improper assembly is likely), do not operate - conduct assembly again.

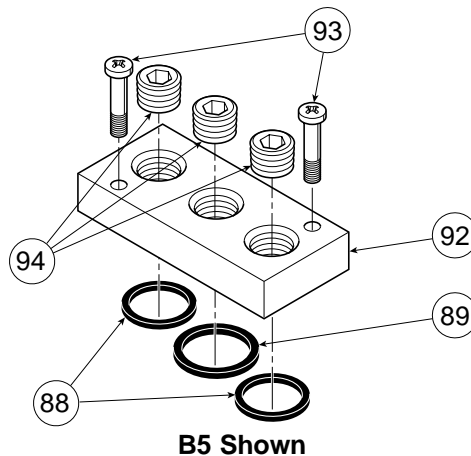

B5 Shown



Pneumatic Division North America
 Richland, Michigan 49083

Installation & Service Instructions
V-381BP

"B2" Series Valves

ISSUED: November, 2000

Supersedes: February, 1994

Rev. 3 ECN# P27922

! WARNING

To avoid unpredictable system behavior that can cause personal injury and property damage:

- Disconnect electrical supply (when necessary) before installation, servicing, or conversion.
- Disconnect air supply and depressurize all air lines connected to this product before installation, servicing, or conversion.
- Operate within the manufacturer's specified pressure, temperature, and other conditions listed in these instructions.
- Medium must be moisture-free if ambient temperature is below freezing.
- Service according to procedures listed in these instructions.
- Installation, service, and conversion of these products must be performed by knowledgeable personnel who understand how pneumatic products are to be applied.
- After installation, servicing, or conversion, air and electrical supplies (when necessary) should be connected and the product tested for proper function and leakage. If audible leakage is present, or the product does not operate properly, do not put into use.
- Warnings and specifications on the product should not be covered by paint, etc. If masking is not possible, contact your local representative for replacement labels.

Application Limits

These products are intended for use in general purpose compressed air systems only.

Operating Pressure Range:

	PSIG	Bar	kPa
Minimum	30	2.0	200
Maximum	120	8.2	820

Operating Temperature Range:

41°F to 122°F (5°C to 50°C)

Voltage Range:

- DC +10% to -15% of Rating
- AC +10% to -10% of Rating

Installation Instructions

Valves should be installed with reasonable accessibility for service. Exercise care in keeping pipe/tube lengths to a minimum.

Piping:

1. Thoroughly flush the inside of pipes before piping. Plumbing should be free of dirt, chips, and scale.
2. When tightening fittings, be careful to prevent thread cuttings and sealants from entering pipes. Pipe joint compound should be used sparingly and applied only to the male pipe, never into the female port.
3. Use appropriate tightening torque to fasten the pipe to its joint as provided in the following table.

Screw Size	Clamping Torque	
M3	2.7 to 4.4 in-lbs	(0.3 to 0.5 Nm)
M5	13 to 18 in-lbs	(1.5 to 2.0 Nm)
1/8" Pipe	62 to 88 in-lbs	(7 to 10 Nm)
1/4" Pipe	106 to 133 in-lbs	(12 to 15 Nm)

Assembly of Valves to Subbase or Manifold:

When assembling valves to their subbase or manifold, torque the mounting screws (cross-recessed head machine screws: M3x22) from 5.3 to 6.2 in-lbs (.6 to .7 Nm).

Wiring:

Follow all requirements for local and national electrical codes.

Electrical Connection: Lead wire and plug-in connectors used have a 2-wire polarity specifications of "+" and "-". Below is a typical example of how the plug-in connectors are attached.

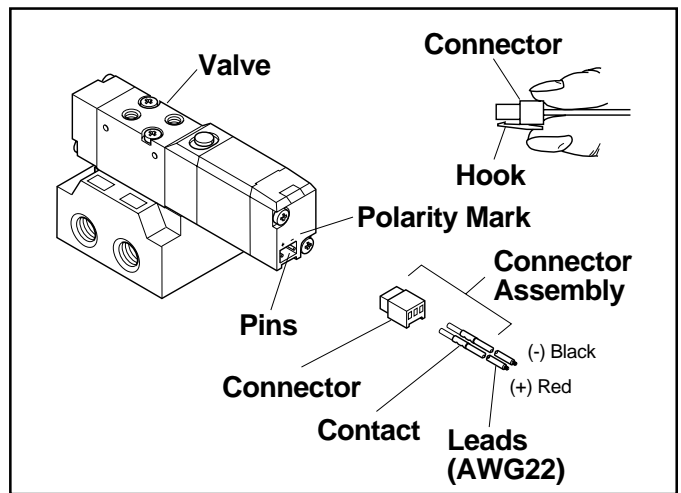

Leak Current:

When a CR (capacitor & resistor) circuit is connected in parallel with relay contacts, a *leak current* will flow through the CR circuit. If this leak current is excessive, the valve's solenoid will malfunction. Thus, leak currents need to be less than the values published in the catalog for the valve in question.

! WARNING

FAILURE OR IMPROPER SELECTION OR IMPROPER USE OF THE PRODUCTS AND/OR SYSTEMS DESCRIBED HEREIN OR RELATED ITEMS CAN CAUSE DEATH, PERSONAL INJURY AND PROPERTY DAMAGE.

This document and other information from Parker Hannifin Corporation, its subsidiaries and authorized distributors provide product and/or system options for further investigation by users having technical expertise. It is important that you analyze all aspects of your application, including consequences of any failure and review the information concerning the product or systems in the current product catalog. Due to the variety of operating conditions and applications for these products or systems, the user, through its own analysis and testing, is solely responsible for making the final selection of the products and systems and assuring that all performance, safety and warning requirements of the application are met.

The products described herein, including without limitation, product features, specifications, designs, availability and pricing, are subject to change by Parker Hannifin Corporation and its subsidiaries at any time without notice.

EXTRA COPIES OF THESE INSTRUCTIONS ARE AVAILABLE FOR INCLUSION IN EQUIPMENT / MAINTENANCE MANUALS THAT UTILIZE THESE PRODUCTS. CONTACT YOUR LOCAL REPRESENTATIVE.

“B2” Series Valves

V-381BP

Quality of Applied Air:

1. Filtered and lubricated air is necessary for maximum valve life and minimum maintenance.
2. Use 5 µm filter or less. When the unit is used with a standard filter and a coalescing filter, air quality will be significantly improved.
3. Use sufficient care to drain the filter(s) periodically.
4. If sludge from the compressor oil enters the air, this will cause problems with pneumatic equipment. Always keep the compressor well maintained.

Ambient Conditions:

1. Protect the valve from exposure to extreme temperatures, dirt, and moisture to maximize valve life.
2. Do not use these valves in an atmosphere containing corrosive gases, chemicals, sea water, water, steam, etc..
3. If the valve is used at a temperature of less than 41°F (5°C), it will freeze. Therefore, take precautions to avoid this type of adverse condition. When the unit is used with dry air (e.g. from an air dryer), its minimum temperature Since these valves are pre-lubricated during assembly, no lubrication is necessary as a general rule. When lubrication is needed, use #1 turbine oil (ISO VG32). If lubrication is used, be sure to continue lubricating the unit to avoid premature valve failure.

CAUTION:

Do not use synthetic, reconstituted, or oils with an alcohol content or detergent additives.

Port Identifications/Connections/Flow Paths

B2G
Single Solenoid
2 Pos.; 3-Way; Normally Closed

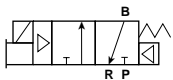

B22
Double Solenoid
2 Pos.; 4-Way

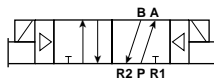

B2H
Single Solenoid
2 Pos.; 3-Way; Normally Open

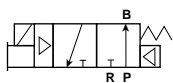

B25
Double Solenoid
3 Pos.; 4-Way;
All Ports Blocked in Neutral

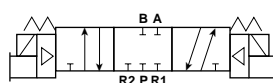

B21
Single Solenoid
2 Pos.; 4-Way

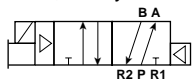

B26
Double Solenoid
3 Pos.; 4-Way
Cyl. Ports Open to Exhaust

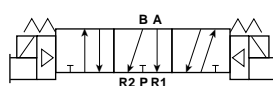

3-Way Service:

Port ID	Single Pressure
P	Inlet
B	Cylinder
R	Exhaust

4-Way Service:

Port ID	Single Pressure
P	Inlet
A	Cylinder
R1	Exhaust
B	Cylinder
R2	Exhaust

Service Procedures

Contact your local authorized dealer or your customer service representative for service information.

Accessories Available

Kit Number	Description
PS3117F02P	2 Station M5 Manifold Base
PS3117F04P	4 Station M5 Manifold Base
PS3117F06P	6 Station M5 Manifold Base
PS3117F08P	8 Station M5 Manifold Base
PS3117F10P	10 Station M5 Manifold Base
PS3117G02P	2 Station 1/8" NPT Manifold Base
PS3117G04P	4 Station 1/8" NPT Manifold Base
PS3117G06P	6 Station 1/8" NPT Manifold Base
PS3117G08P	8 Station 1/8" NPT Manifold Base
PS3117G10P	10 Station 1/8" NPT Manifold Base
PS3120P	Blanking Plate Kit
PS31316P	Electrical Connector Kit - 20" Leads
PS31333P	3-Way Subbase Kit M5
PS31334P	4-Way Subbase Kit M5
PS31343P	3-Way Subbase Kit 1/8" NPT
PS31344P	4-Way Subbase Kit 1/8" NPT



Pneumatic Division
 Richland, Michigan 49083

Installation & Service Instructions
V-390P
"B3B" Series Air Control Valves
1/8" Inline & 1/8" & 1/4" Subbase
ISSUED: August, 1994
Supersedes: N/A
NPR 1182

⚠ WARNING

To avoid unpredictable system behavior that can cause personal injury and property damage:

- Disconnect electrical supply (when necessary) before installation, servicing, or conversion.
- Disconnect air supply and depressurize all air lines connected to this product before installation, servicing, or conversion.
- Operate within the manufacturer's specified pressure, temperature, and other conditions listed in these instructions.
- Medium must be moisture-free if ambient temperature is below freezing.
- Service according to procedures listed in these instructions.
- Installation, service, and conversion of these products must be performed by knowledgeable personnel who understand how pneumatic products are to be applied.
- After installation, servicing, or conversion, air and electrical supplies (when necessary) should be connected and the product tested for proper function and leakage. If audible leakage is present, or the product does not operate properly, do not put into use.
- Warnings and specifications on the product should not be covered by paint, etc. If masking is not possible, contact your local representative for replacement labels.

Specifications

These products are intended for use in general purpose compressed air systems only.

Operating Pressure (2-Position):

	psig	bar	kPa
Minimum	20	1.4	138
Maximum	150	10.3	1030

Operating Pressure (3-Position):

	psig	bar	kPa
Minimum	30	2.1	207
Maximum	150	10.3	1030

NOTE: Solenoid operated valves specified for external pilot or double air pilot operated valves, may have pressures down to vacuum in the main valve. External pilot pressure and air pilot signals must be greater than or equal to that in the main valve, but do not exceed the ranges above.

Temperature Range (Ambient):

5°F to 120°F (-15°C to 50°C)

Voltage Range: + 10% to -10% of Rating

Accessories:

Kit No.	Description
PS2915P	Manifold End Plate Kit
PS2917P	Manifold w/o Flow Control Kit
PS2918P	Manifold w/Flow Control Kit
PS2919P	Isolation Plug Kit
PS2920P	Inlet Block/Blanking Plate Kit
PS2932P	3-Pin Connector Kit – Unlighted
PS294675P	3-Pin Connector Kit – Lighted, 12VAC & VDC
PS294679P	3-Pin Connector Kit – Lighted, 24VAC & VDC
PS294683P	3-Pin Connector Kit – Lighted, 120VAC

Materials:

Solenoid Adapter	Aluminum
Return Body	Polyamide
Pilot Valving Elements	Acetal & Polyamide
Solenoid Poppets	Flurocarbon
Other Seals	Nitrile
Screws/Springs	Steel
Armature Assembly	Steel & Brass
Coil	Copper & Plastic
Main Valve	Aluminum
Main Valving Elements	Aluminum & Nitrile

Installation Instructions

Valve should be installed with reasonable accessibility for service. Exercise care in keeping pipe/tube lengths to a minimum. Plumbing should be free of dirt, chips, & scale. Pipe joint compound should be applied sparingly, and only to the male threads, never to the female threads. Protect the valve from exposure to extreme temperatures, dirt, and moisture to maximize life.

Air applied to the valve must be filtered to realize maximum component life.

⚠ CAUTION:

It is recommended that double operated 2-position valves be mounted so that the axis of the main valve spool is in the horizontal plane. The valve may be rotated 360° around the axis for mounting convenience.

Factory Pre-Lubrication – All valves are pre-lubricated at the factory. In-service lubrication is recommended. Valves will operate without added lubrication but with reduced service life.

Subbase Valves:

When mounting subbase valves to their bases, install the interface gasket to the bottom of the valve body and push the

⚠ WARNING

FAILURE OR IMPROPER SELECTION OR IMPROPER USE OF THE PRODUCTS AND/OR SYSTEMS DESCRIBED HEREIN OR RELATED ITEMS CAN CAUSE DEATH, PERSONAL INJURY AND PROPERTY DAMAGE.

This document and other information from Parker Hannifin Corporation, its subsidiaries and authorized distributors provide product and/or system options for further investigation by users having technical expertise. It is important that you analyze all aspects of your application, including consequences of any failure and review the information concerning the product or systems in the current product catalog. Due to the variety of operating conditions and applications for these products or systems, the user, through its own analysis and testing, is solely responsible for making the final selection of the products and systems and assuring that all performance, safety and warning requirements of the application are met.

The products described herein, including without limitation, product features, specifications, designs, availability and pricing, are subject to change by Parker Hannifin Corporation and its subsidiaries at any time without notice.

EXTRA COPIES OF THESE INSTRUCTIONS ARE AVAILABLE FOR INCLUSION IN EQUIPMENT / MAINTENANCE MANUALS THAT UTILIZE THESE PRODUCTS. CONTACT YOUR LOCAL REPRESENTATIVE.

rubber projections into their appropriate holes. Place the valve on the base noting the relative position of the rubber projections to the holes in the base. Install the two (2) socket head cap screws provided and tighten to 15 in-lbs torque using 2.5mm hex wrench. Plumb the valve, turn on air pressure and electrical power source. Test valve for functional operation and for internal and external leakage. If leakage is audible (indicating improper assembly is likely), do not operate; conduct assembly again.

In-Service Lubrication:

Parker F442P oil is recommended. This oil is specially formulated to provide peak performance and maximum service life from all air operated equipment. Alternative compatible lubricants should be of a paraffin based mineral oil having 150 to 200 SSU viscosity @ 100°F and an aniline point greater than 200°F. (Mobil DTE24 and Sun Company Sunvis 932 are good examples.)

CAUTION:

Do not use synthetic, reconstituted, or oils with an alcohol content or detergent additives.

ANSI Symbols

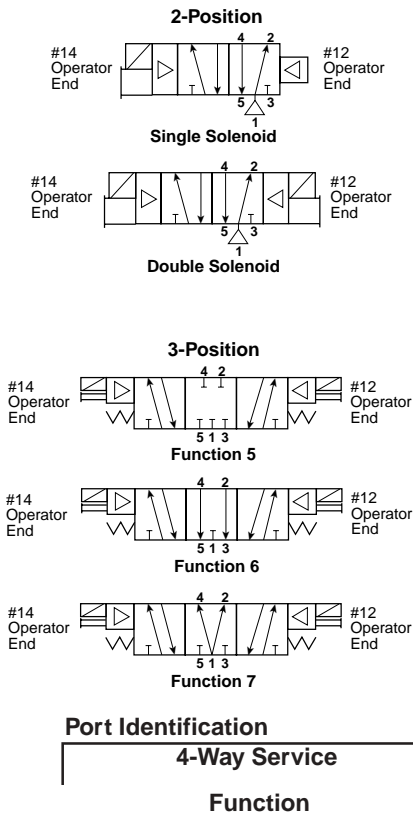

Port No.	Single Pressure	Dual Pressure
1	Inlet	Exhaust
2	Cylinder	Cylinder
3	Exhaust	Inlet
4	Cylinder	Cylinder
5	Exhaust	Inlet

NOTE: For valves specified for dual pressure, the higher pressure is to be at port #3.

Valves may be used for 3-Way function by plugging an outlet port.

NOTE: For single pressure valves, the operator nearest a cylinder port causes that cylinder port to be pressurized, when that operator is in control of the valve.

Wiring

Follow all requirements for local and national electrical codes.

Electrical Connection:

1. Valves with lead wires should have power connected to the black wires. Ground should be connected to the green wire if provided.
2. Valves with 3-pin male terminals should have power connected to the parallel terminals. Ground should be connected to the perpendicular terminal.

Service Instructions

The following service kits contain the appropriate seals and parts necessary for ordinary field service.

Kit No.	Description
PS2901BP	2-Position body service kit
PS2902BP	3-Position all ports blocked body service kit
PS2903BP	3-Position cylinder to exhaust body service kit
PS2904BP	3-Position pressure center body service kit
PS2928G40BP	12VAC Solenoid Kit – 18" Flying Leads
PS2928G42BP	24VAC Solenoid Kit – 18" Flying Leads
PS2928G53BP	120VAC Solenoid Kit – 18" Flying Leads
PS2928P45BP	12VDC Solenoid Kit – 18" Flying Leads
PS2928P49BP	24VDC Solenoid Kit – 18" Flying Leads
PS2928540BP	12VAC Solenoid Kit – 3 Pin Connector
PS2928542BP	24VAC Solenoid Kit – 3 Pin Connector
PS2928545BP	12VDC Solenoid Kit – 3 Pin Connector
PS2928549BP	24VDC Solenoid Kit – 3 Pin Connector
PS2928553BP	120VAC Solenoid Kit – 3 Pin Connector
PS2944P	Solenoid Base / Armature with Manual Override
PS2945P	Solenoid Base / Armature <u>without</u> Manual Override

Service Instruction Sheets:

V-391P	2-Position body service instruction sheet
V-392P	3-Position body service instruction sheet
V-393P	Solenoid & pilot body service instruction sheet
V-394P	Manifold & accessory instruction sheet



Pneumatic Division
 Richland, Michigan 49083

Installation & Service Instructions
V-391P

"B3B" Series Air Control Valves
1/8" Inline & 1/8" & 1/4" Subbase
2-Position Body

ISSUED: November, 1994
NPR# 1189

 **WARNING**

To avoid unpredictable system behavior that can cause personal injury and property damage:

- Disconnect electrical supply (when necessary) before installation, servicing, or conversion.
- Disconnect air supply and depressurize all air lines connected to this product before installation, servicing, or conversion.
- Operate within the manufacturer's specified pressure, temperature, and other conditions listed in these instructions.
- Medium must be moisture-free if ambient temperature is below freezing.
- Service according to procedures listed in these instructions.
- Installation, service, and conversion of these products must be performed by knowledgeable personnel who understand how pneumatic products are to be applied.
- After installation, servicing, or conversion, air and electrical supplies (when necessary) should be connected and the product tested for proper function and leakage. If audible leakage is present, or the product does not operate properly, do not put into use.
- Warnings and specifications on the product should not be covered by paint, etc. If masking is not possible, contact your local representative for replacement labels.

Specifications

These products are intended for use in general purpose compressed air systems only.

Operating Pressure Range:

	psig	bar	kPa
Minimum	20	1.4	138
Maximum	150	10.3	1030

NOTE: Solenoid operated valves specified for external pilot or double air pilot operated valves, may have pressures down to vacuum in the main valve. External pilot pressure and air pilot signals must be greater than or equal to that in the main valve, but do not exceed the ranges above.

Temperature Range (Ambient):

5°F to 120°F (-15°C to 50°C)

Voltage Range:

+10% to -10% of Rating

Wiring:

Follow all requirements for local and national electrical codes. Wiring instructions and instructions for proper installation are shown on Instruction Form V-390P which is shipped with the original product. Copies of Instruction Form V-390P are available from your local representative.

Service Instructions

Subbase Valves:

If valves are removed from their bases during repair, reassemble valve to base using proper gasket orientation. Reinstall the two socket head cap screws and tighten to 15 in-lbs torque using a 2.5 mm hex wrench. Test the assembly for proper function and leakage before putting into service.

Servicing Valve Body:

NOTE: If servicing double solenoid operated valve, instructions for solenoid operator apply to both ends of the valve - disregard references to air return operator.

1. Remove solenoid coil from the main valve body by removing knurled nut and washer. Then remove the two cheese head screws which secure the solenoid base to the solenoid adapter. Remove the two o-rings between solenoid base and adapter. Remove the solenoid adaptor and return operator by removing their two mounting screws.

NOTE: Keep track of how the parts fit together to aid with re-assembly of valve. Refer to illustration for proper part orientation. Clean all parts which are going to be reused (such as seals and gaskets, piston, piston bores, gasket tracks, spools, etc.) with a lint free cloth. Apply fresh grease (provided) to all seals prior to reassembly.

2. Remove pistons from the solenoid adapter and return operator. Remove the lip seals from the pistons.
3. Remove the seals (items 11 and/or 16) from the adapter and return operator. Inspect piston bores for nicks, scratches and surface imperfections.
4. Push spool/seal assembly from body and clean valve bore, taking care not to scratch bore. (If more aggressive cleaning is required, use mineral spirits or equivalent solvent and dry thoroughly). Inspect body's bore for nicks, scratches, or surface imperfections.

NOTE: The presence of nicks, scratches and surface imperfections may reduce service life; thus, future replacement of damaged parts should be planned.

5. Lightly grease seals on the spool assembly and install it into valve bore. Take care to install spool squarely and push slowly to avoid damaging seals or the body's bore.
6. Lightly grease new seals and install between solenoid adapter & body; and between body & return operator. (The seal for the return operator is custom molded, whereas an o-ring is used for the solenoid adapter and air pilot operator.)

 **WARNING**

FAILURE OR IMPROPER SELECTION OR IMPROPER USE OF THE PRODUCTS AND/OR SYSTEMS DESCRIBED HEREIN OR RELATED ITEMS CAN CAUSE DEATH, PERSONAL INJURY AND PROPERTY DAMAGE.

This document and other information from Parker Hannifin Corporation, its subsidiaries and authorized distributors provide product and/or system options for further investigation by users having technical expertise. It is important that you analyze all aspects of your application, including consequences of any failure and review the information concerning the product or systems in the current product catalog. Due to the variety of operating conditions and applications for these products or systems, the user, through its own analysis and testing, is solely responsible for making the final selection of the products and systems and assuring that all performance, safety and warning requirements of the application are met.

The products described herein, including without limitation, product features, specifications, designs, availability and pricing, are subject to change by Parker Hannifin Corporation and its subsidiaries at any time without notice.

EXTRA COPIES OF THESE INSTRUCTIONS ARE AVAILABLE FOR INCLUSION IN EQUIPMENT / MAINTENANCE MANUALS THAT UTILIZE THESE PRODUCTS. CONTACT YOUR LOCAL REPRESENTATIVE.

7. Apply a light film of grease to operator piston bores and all surfaces of piston seals. Install seals onto piston with the lips of the seals facing away from the support flange. (Depending on the type of valve being serviced, there will be extra piston seals.) Install the piston/seal assemblies into their operator bores, taking care to assure that the lips of the seals pass smoothly into the bores.
8. Reassemble the solenoid adapter and return operator (to the same ends as before) using their two mounting screws - be sure to install seals in their appropriate counter bores; torque screws to 10-12 in-lbs. Attach the solenoid base to the adapter using the two cheese head screws; torque to 4-6 in-lbs. Assemble the coil onto the base using the washer and knurled nut; finger tight.
9. Turn on air pressure and electrical power source. Test valve for functional operation and leakage (both internal and external). If leakage is audible (indicating improper repairs are likely), do not operate - conduct repairs again.

Service Kits

The following service kits contain the appropriate seals and parts necessary for ordinary field service.

<u>Kit No</u>	<u>Description</u>
PS2901BP	2-Position Body Service Kit
PS2928G40BP	12VAC Solenoid Kit - 18" Flying Leads
PS2928G42BP	24VAC Solenoid Kit - 18" Flying Leads
PS2928G53BP	120VAC Solenoid Kit - 18" Flying Leads
PS2928P45BP	12VDC Solenoid Kit - 18" Flying Leads
PS2928P49BP	24VDC Solenoid Kit - 18" Flying Leads
PS2928540BP	12VAC Solenoid Kit - 3-Pin Connector
PS2928542BP	24VAC Solenoid Kit - 3-Pin Connector
PS2928545BP	12VDC Solenoid Kit - 3-Pin Connector
PS2928549BP	24VDC Solenoid Kit - 3-Pin Connector
PS2928553BP	120VAC Solenoid Kit - 3-Pin Connector
PS2944P	Solenoid Base/Armature with Manual Override
PS2945P	Solenoid Base/Armature <u>without</u> Manual Override

Other Service Instruction Sheets:

V-390P	Valve Installation & Service Instruction Sheet
V-393P	Solenoid & Pilot Body Service Instruction Sheet
V-374P	Manifold & Accessory Instruction Sheet
V-395P	Conversion Kit Instruction Sheet (B3B Operator)

Accessories

<u>Kit No</u>	<u>Description</u>
PS2915P	Manifold End Plate Kit
PS2917P	Manifold <u>without</u> Flow Control Kit
PS2918P	Manifold with Flow Control Kit
PS2919P	Isolation Plug Kit
PS2920P	Inlet Block/Blanking Plate Kit
PS2932P	3-Pin Connector Kit - Unlighted
PS294675P	3-Pin Connector Kit - Lighted, 12VAC & VDC
PS294679P	3-Pin Connector Kit - Lighted, 24VAC & VDC
PS294683P	3-Pin Connector Kit - Lighted, 120VAC

Part Identification List

<u>Item #</u>	<u>Description</u>
1	Knurled Nut
2	Washer (Spring)
3	Coil Assembly
4	Cheese Head Mounting Screw - base to adapter
5	Solenoid Base
6	O-ring (2.5 x 1.5 mm)
7	O-ring (11.5 x 1.5 mm)
8	Mounting Screws - adapter to body (not shown)
9	Solenoid Adapter
10	Lip Seal - solenoid end
11	O-ring - adapter to body
12	Piston - solenoid end
13	Spool Assembly
14	Valve Body
15	Piston - return operator end
16	Seal - return operator to body
17	Lip Seal - return operator end
18	Return Spring - (special option only)
19	Return Operator
20	Mounting Screws - return operator to body

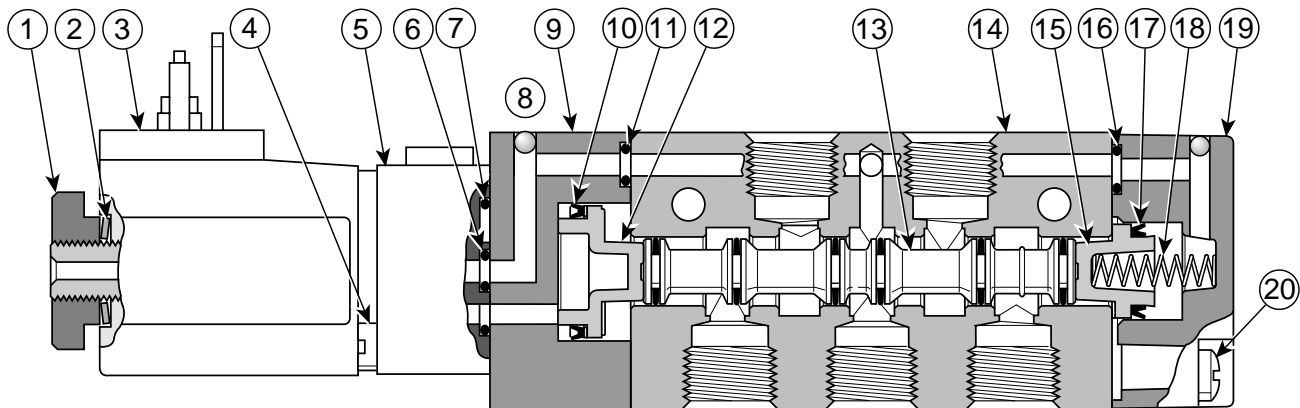



Pneumatic Division
 Richland, Michigan 49083

Installation & Service Instructions
V-392P

"B3B" Series Air Control Valves
1/8" Inline & 1/8" & 1/4" Subbase
3-Position Body

ISSUED: September, 1994
NPR# 1189

 **WARNING**

To avoid unpredictable system behavior that can cause personal injury and property damage:

- Disconnect electrical supply (when necessary) before installation, servicing, or conversion.
- Disconnect air supply and depressurize all air lines connected to this product before installation, servicing, or conversion.
- Operate within the manufacturer's specified pressure, temperature, and other conditions listed in these instructions.
- Medium must be moisture-free if ambient temperature is below freezing.
- Service according to procedures listed in these instructions.
- Installation, service, and conversion of these products must be performed by knowledgeable personnel who understand how pneumatic products are to be applied.
- After installation, servicing, or conversion, air and electrical supplies (when necessary) should be connected and the product tested for proper function and leakage. If audible leakage is present, or the product does not operate properly, do not put into use.
- Warnings and specifications on the product should not be covered by paint, etc. If masking is not possible, contact your local representative for replacement labels.

Specifications

These products are intended for use in general purpose compressed air systems only.

Operating Pressure Range:

	psig	bar	kPa
Minimum	30	2.1	207
Maximum	150	10.3	1030

NOTE: Solenoid operated valves specified for external pilot or double air pilot operated valves, may have pressures down to vacuum in the main valve. External pilot pressure and air pilot signals must be greater than or equal to that in the main valve, but do not exceed the ranges above.

Temperature Range (Ambient):

5°F to 120°F (-15°C to 50°C)

Voltage Range:

+10% to -10% of Rating

Wiring:

Follow all requirements for local and national electrical codes. Wiring instructions and instructions for proper installation are shown on Instruction Form V-390P which is shipped with the original product. Copies of Instruction Form V-390P are available from your local representative.

Service Instructions

Subbase Valves:

If valves are removed from their bases during repair, reassemble valve to base using proper gasket orientation. Reinstall the two socket head cap screws and tighten to 15 in-lbs torque using a 2.5 mm hex wrench. Test the assembly for proper function and leakage before putting into service.

Servicing Valve Body:

1. Remove both solenoid coils from the main valve body by removing knurled nuts and washers. Then remove the two cheese head screws which secure the solenoid bases to their solenoid adapters. Remove the two o-rings between solenoid base and adapter. Remove both solenoid adapters by removing their two mounting screws.

NOTE: Keep track of how the parts fit together to aid with re-assembly of valve. Refer to illustration for proper part orientation. Clean all parts which are going to be reused (such as seals and gaskets, piston, piston bores, gasket tracks, spools, etc.) with a lint free cloth. Apply fresh grease (provided) to all seals prior to reassembly.

2. Remove pistons from solenoid adapters. Then remove lip seals from their pistons.
3. Remove the o-rings (item 11) between body and solenoid adapters. Inspect piston bores for nicks, scratches and surface imperfections.
4. Push spool/seal assembly from body and clean valve bore, taking care not to scratch bore. (If more aggressive cleaning is required, use mineral spirits or equivalent solvent and dry thoroughly). Inspect body's bore for nicks, scratches, or surface imperfections.

NOTE: The presence of nicks, scratches and surface imperfections may reduce service life; thus, future replacement of damaged parts should be planned.

5. Lightly grease seals on the spool assembly and install it into valve bore. Take care to install spool squarely and push slowly to avoid damaging seals or the body's bore.
6. Lightly grease new seals and install between body and solenoid adapters.
7. Apply a light film of grease to operator piston bores and all surfaces of piston seals. Install seals onto pistons with the lips of the seals facing away from the support flange. Install the piston/seal assemblies into their operator bores, taking care to assure that the lips of the seals pass smoothly into the bores.

 **WARNING**

FAILURE OR IMPROPER SELECTION OR IMPROPER USE OF THE PRODUCTS AND/OR SYSTEMS DESCRIBED HEREIN OR RELATED ITEMS CAN CAUSE DEATH, PERSONAL INJURY AND PROPERTY DAMAGE.

This document and other information from Parker Hannifin Corporation, its subsidiaries and authorized distributors provide product and/or system options for further investigation by users having technical expertise. It is important that you analyze all aspects of your application, including consequences of any failure and review the information concerning the product or systems in the current product catalog. Due to the variety of operating conditions and applications for these products or systems, the user, through its own analysis and testing, is solely responsible for making the final selection of the products and systems and assuring that all performance, safety and warning requirements of the application are met.

The products described herein, including without limitation, product features, specifications, designs, availability and pricing, are subject to change by Parker Hannifin Corporation and its subsidiaries at any time without notice.

EXTRA COPIES OF THESE INSTRUCTIONS ARE AVAILABLE FOR INCLUSION IN EQUIPMENT / MAINTENANCE MANUALS THAT UTILIZE THESE PRODUCTS. CONTACT YOUR LOCAL REPRESENTATIVE.

8. Reassemble the solenoid adapters (to the same ends as before) using their two mounting screws - be sure to install seals in their appropriate counter bores; torque screws to 10-12 in-lbs. Attach the solenoid bases to the adapters using the two cheese head screws; torque to 4-6 in-lbs. Assemble the coils onto the bases using the washers and knurled nuts; finger tight.
9. Turn on air pressure and electrical power source. Test valve for functional operation and leakage (both internal and external). If leakage is audible (indicating improper repairs are likely), do not operate - conduct repairs again.

Service Kits

The following service kits contain the appropriate seals and parts necessary for ordinary field service.

Kit No	Description
PS2902BP	3-Position all ports blocked body Service Kit
PS2903BP	3-Position cylinder to exhaust body Service Kit
PS2904BP	3-Position pressure center body Service Kit
PS2928G40BP	12VAC Solenoid Kit - 18" Flying Leads
PS2928G42BP	24VAC Solenoid Kit - 18" Flying Leads
PS2928G53BP	120VAC Solenoid Kit - 18" Flying Leads
PS2928P45BP	12VDC Solenoid Kit - 18" Flying Leads
PS2928P49BP	24VDC Solenoid Kit - 18" Flying Leads
PS2928540BP	12VAC Solenoid Kit - 3-Pin Connector
PS2928542BP	24VAC Solenoid Kit - 3-Pin Connector
PS2928545BP	12VDC Solenoid Kit - 3-Pin Connector
PS2928549BP	24VDC Solenoid Kit - 3-Pin Connector
PS2928553BP	120VAC Solenoid Kit - 3-Pin Connector
PS2944P	Solenoid Base/Armature with Manual Override
PS2945P	Solenoid Base/Armature <u>without</u> Manual Override

Other Service Instruction Sheets:

V-390P	Valve Installation & Service Instruction Sheet
V-393P	Solenoid & Pilot Body Service Instruction Sheet
V-394P	Manifold & Accessory Instruction Sheet
V-395P	Conversion Kit Instruction Sheet (B3B Operator)

Accessories

Kit No	Description
PS2915P	Manifold End Plate Kit
PS2917P	Manifold <u>without</u> Flow Control Kit
PS2918P	Manifold with Flow Control Kit
PS2919P	Isolation Plug Kit
PS2920P	Inlet Block/Blanking Plate Kit
PS2932P	3-Pin Connector Kit - Unlighted
PS294675P	3-Pin Connector Kit - Lighted, 12VAC & VDC
PS294679P	3-Pin Connector Kit - Lighted, 24VAC & VDC
PS294683P	3-Pin Connector Kit - Lighted, 120VAC

Part Identification List

Item #	Description
1	Knurled Nut
2	Washer (Spring)
3	Coil Assembly
4	Cheese Head Mounting Screw - base to adapter
5	Solenoid Base
6	O-ring (2.5 x 1.5 mm)
7	O-ring (11.5 x 1.5 mm)
8	Mounting Screws - adapter to body
9	Solenoid Adapter
10	Lip Seal
11	O-ring - adapter to body
12	Piston Assembly
13	Spool Assembly
14	Valve Body

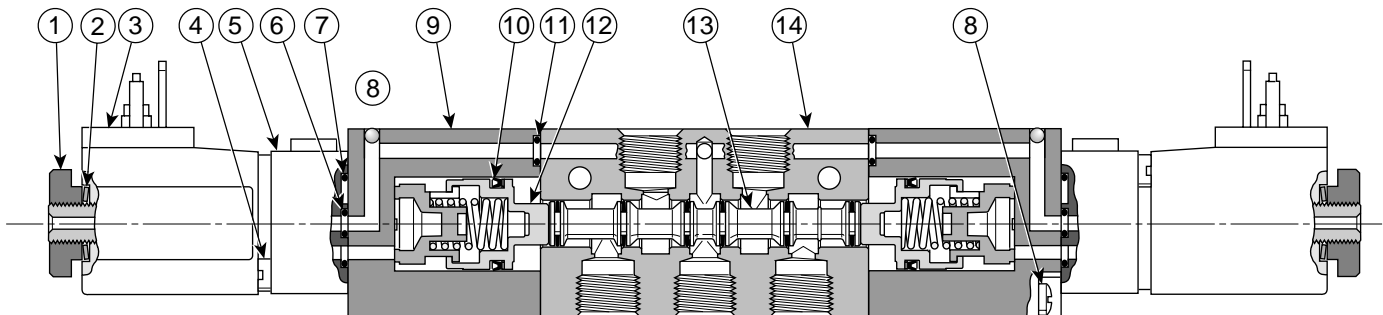



Pneumatic Division
Richland, Michigan 49083

Installation & Service Instructions
V-393BP

“B3...B” Series Air Control Valves
1/8" Inline & 1/8" & 1/4" Subbase

ISSUED: October, 1995

Supersedes: September, 1994

ECN 25653

Replacement of “B3...B” Solenoid Assembly

WARNING

To avoid unpredictable system behavior that can cause personal injury and property damage:

- Disconnect electrical supply (when necessary) before installation, servicing, or conversion.
- Disconnect air supply and depressurize all air lines connected to this product before installation, servicing, or conversion.
- Operate within the manufacturer’s specified pressure, temperature, and other conditions listed in these instructions.
- Medium must be moisture-free if ambient temperature is below freezing.
- Service according to procedures listed in these instructions.
- Installation, service, and conversion of these products must be performed by knowledgeable personnel who understand how pneumatic products are to be applied.
- After installation, servicing, or conversion, air and electrical supplies (when necessary) should be connected and the product tested for proper function and leakage. If audible leakage is present, or the product does not operate properly, do not put into use.
- Warnings and specifications on the product should not be covered by paint, etc. If masking is not possible, contact your local representative for replacement labels.

Introduction

Follow these instructions when replacing a solenoid coil assembly on B3 valves at engineering level “B”.

Application Limits

These products are intended for use in general purpose compressed air systems only.

Operating Inlet Pressure:

	kPa	psig	bar
Min. (2-Position)	140	20	1.4
Min. (2-Position w/Spring and Air Return)	240	35	2.4
Min. (3-Position)	210	30	2.1
Max. (2 & 3-Position)	1030	150	10.3

NOTE: Solenoid operated valves, when specified with external pilot, may have operating pressures down to vacuum in the main valve. External pilot pressure and air pilot signals must be greater than or equal to that in the main valve, but not outside the ratings above.

Ambient Temperature Range: -15°C to 50°C (5°F to 120°F)

Voltage Range: Rated Voltage +10%, -10%

Wiring

Follow all requirements for local and national electrical codes.

Electrical Connection:

1. Valves with 3-pin male terminals should have power connected to the parallel terminals. Ground should be connected to the perpendicular terminal.
2. Valves with lead wires should have power connected to the black wires.

Accessories

Kit No.	Description
PS2915P	Manifold End Plate Kit
PS2917P	Manifold w/o Flow Control Kit
PS2918P	Manifold w/Flow Control Kit
PS2919P	Isolation Plug Kit
PS2920P	Inlet Block/Blanking Plate Kit
PS2932P	3-Pin Connector Kit - Unlighted
PS294675P	3-Pin Connector Kit - Lighted, 12VAC & VDC
PS294679P	3-Pin Connector Kit - Lighted, 24VAC & VDC
PS294683P	3-Pin Connector Kit - Lighted, 120VAC
PS2932JP	3-Pin Connector Kit - Unlighted with 2 meter cord
PS2946J75P	3-Pin Connector Kit - Lighted, 12VAC & DC with 2 meter cord
PS2946J79P	3-Pin Connector Kit - Lighted, 24 VAC & DC with 2 meter cord
PS2946J83P	3-Pin Connector Kit - Lighted, 120VAC with 2 meter cord

WARNING

FAILURE OR IMPROPER SELECTION OR IMPROPER USE OF THE PRODUCTS AND/OR SYSTEMS DESCRIBED HEREIN OR RELATED ITEMS CAN CAUSE DEATH, PERSONAL INJURY AND PROPERTY DAMAGE.

This document and other information from Parker Hannifin Corporation, its subsidiaries and authorized distributors provide product and/or system options for further investigation by users having technical expertise. It is important that you analyze all aspects of your application, including consequences of any failure and review the information concerning the product or systems in the current product catalog. Due to the variety of operating conditions and applications for these products or systems, the user, through its own analysis and testing, is solely responsible for making the final selection of the products and systems and assuring that all performance, safety and warning requirements of the application are met.

The products described herein, including without limitation, product features, specifications, designs, availability and pricing, are subject to change by Parker Hannifin Corporation and its subsidiaries at any time without notice.

EXTRA COPIES OF THESE INSTRUCTIONS ARE AVAILABLE FOR INCLUSION IN EQUIPMENT / MAINTENANCE MANUALS THAT UTILIZE THESE PRODUCTS. CONTACT YOUR LOCAL REPRESENTATIVE.

Service Instructions

1. Remove solenoid nut (Item 5) and washer (Item 6).
2. Slide coil off from the end of the old solenoid base (Item 2).
3. Remove old solenoid base by unscrewing both screws (Item 7). Be sure that the inner and outer o-rings (located between the solenoid base and the adapter) are removed at this time.
4. Grease the new inner o-ring (Item 3) and place in the small round groove on the face of the new solenoid base, as shown in drawing.
5. Grease the new outer o-ring (Item 4) and place in the large round groove on the face of the new solenoid base, as shown in drawing.
6. Connect new solenoid base to the adapter, using two screws (Item 7), so that the override is on top. Tighten from 0.5 to 0.7 Nm (4 to 6 in-lbs) of torque.
7. Slide new coil onto the end of the solenoid base, so that the three pin connector or wire leads are on top.
8. Place washer onto end of coil.
9. Screw solenoid nut onto the end of the coil and finger tighten.

10. Make plumbing and electrical connections.

11. Turn on air pressure and electrical power source. Test for proper functional operation. Test for internal and external air leakage. If leakage is audible do not operate and conduct assembly again.



CAUTION:

It is recommended that double operated 2-Position valves be mounted so that the axis of the main valve spool is in the horizontal plane. The valve may be rotated to any angle around the axis for mounting convenience.

Part Identification List

Item #	Description
1	Coil Assembly (purchase separately)
2	Solenoid Base
3	O-ring Inner (2.5 x 1.5 mm)
4	O-ring Outer (11.5 x 1.5 mm)
5	Knurled Nut
6	Washer (Spring)
7	Screw (solenoid base/adapter)

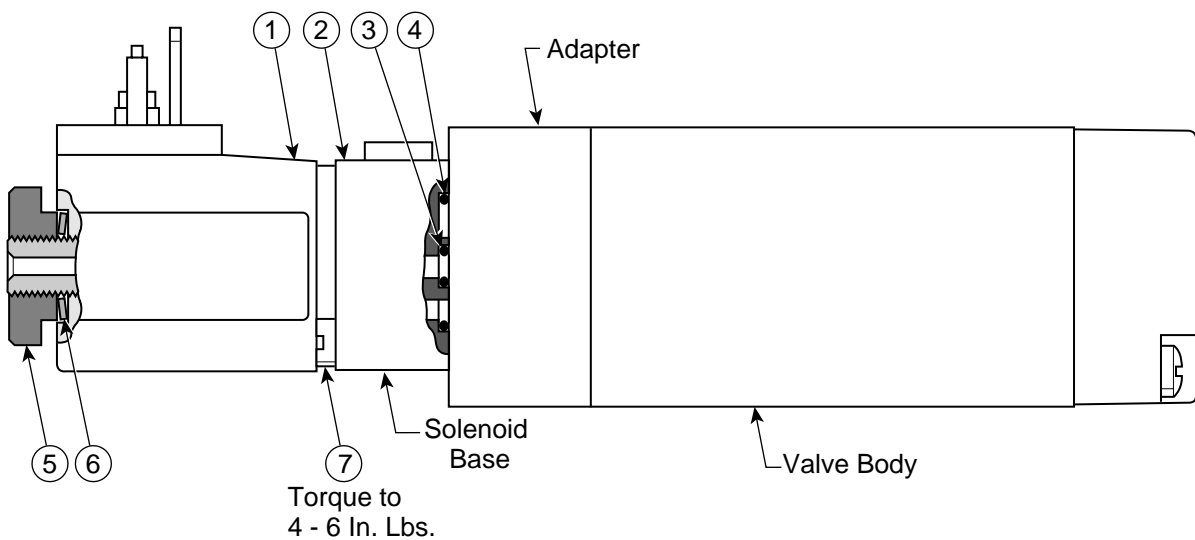
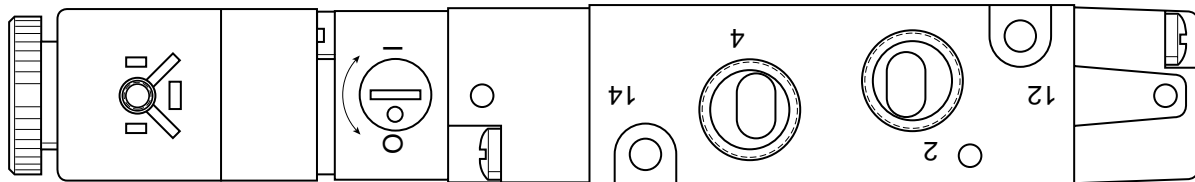

**Single Solenoid Operated
Valve Illustrated**



Pneumatic Division North America
Richland, Michigan 49083

Installation & Service Instructions
V400BP
"B3...C" Series Air Control Valves
3-Way: Inline
4-Way: Inline & Subbase
ISSUED: September, 2006
Supersedes: August, 2005
DOC.# V-400P, ECN# 060870 Rev. 5

WARNING

To avoid unpredictable system behavior that can cause personal injury and property damage:

- Disconnect electrical supply (when necessary) before installation, servicing, or conversion.
- Disconnect air supply and depressurize all air lines connected to this product before installation, servicing, or conversion.
- Operate within the manufacturer's specified pressure, temperature, and other conditions listed in these instructions.
- Medium must be moisture-free if ambient temperature is below freezing.
- Service according to procedures listed in these instructions.
- Installation, service, and conversion of these products must be performed by knowledgeable personnel who understand how pneumatic products are to be applied.
- After installation, servicing, or conversion, air and electrical supplies (when necessary) should be connected and the product tested for proper function and leakage. If audible leakage is present, or the product does not operate properly, do not put into use.
- Warnings and specifications on the product should not be covered by paint, etc. If masking is not possible, contact your local representative for replacement labels.

Safety Guide

For more complete information on recommended application guidelines, see the Safety Guide section of Pneumatic Division catalogs or you can download the **Pneumatic Division Safety Guide** at: www.parker.com/safety

Introduction

Follow these instructions when installing, operating, or servicing the product.

Application Limits

These products are intended for use in general purpose compressed air systems only.

Operating Inlet Pressure:

	kPa	psig	bar
Min. (2-Position)	140	20	1.4
Min. (2-Position w/Spring and Air Return)	240	35	2.4
Min. (3-Position)	210	30	2.1
Max. (2 & 3-Position)	1030	150	10.3

NOTE: Solenoid operated valves, when specified with external pilot, may have operating pressures down to vacuum in the main valve. External pilot pressure and air pilot signals must be greater than or equal to that in the main valve, but not outside the ratings above.

Ambient Temperature Range: -15°C to 50°C (5°F to 120°F)

Voltage Range: Rated Voltage +10%, -15%

Installation Instructions

Valve should be installed with reasonable accessibility for service. Exercise care in keeping pipe/tube lengths to a minimum. Plumbing should be free of dirt, chips, & scale. Pipe joint compound should be applied sparingly, and only to the male threads, never to the female threads. Protect the valve from exposure to extreme temperatures, dirt, and moisture to maximize life.

Series "B3...C" valves with integral PRESTOLOK ports must use

Parker PARFLEX tubing, which has the required O.D. tolerances for use with PRESTOLOK ports. Be sure to use the tubing support (part no. 63 PTU) when using the series U polyurethane tubing. All applications should be carefully tested through the full range of conditions which may be encountered prior to use.

Air applied to the valve must be filtered to realize maximum component life.

CAUTION: It is recommended that double operated 2-position valves be mounted so that the axis of the main valve spool is in the horizontal plane. The valve may be rotated to any angle around the axis for mounting convenience.

Factory Pre-Lubrication – All valves are pre-lubricated at the factory. In-service lubrication is recommended. Valves will operate without added lubrication but with reduced service life.

Subbase Valves:

When mounting subbase valves to their bases, install the interface gasket to the bottom of the valve body and push the rubber projections into their appropriate holes. Place the valve on the base noting the relative position of the rubber projections to the holes in the base. Install the two socket head cap screws provided and tighten to 1.1 to 1.4 Nm (10 to 12 in lb) torque using 2.5mm hex wrench. Plumb the valve, turn on air pressure and electrical power source. Test valve for functional operation and for internal and external leakage. If leakage is audible (indicating improper assembly is likely), do not operate; conduct assembly again.

Manual Override:

A manual override (if supplied) is located on the body of the solenoid pilot, either on the same side or on the opposite side as the electrical terminals. A non-locking override is blue and must be twisted approx. 45° in either direction (and held at that position) in order to actuate the solenoid pilot. When released, the solenoid pilot will de-actuate. A flush type override requires use of a small screwdriver engaged in a slot on the end of the override button; a lever style override can be turned by finger. Locking overrides are yellow and must be twisted approx. 90° in either direction in order to actuate the solenoid pilot. They must be returned with a reverse twist to de-actuate. These are also either flush or extended types and operate as described above.

WARNING

FAILURE OR IMPROPER SELECTION OR IMPROPER USE OF THE PRODUCTS AND/OR SYSTEMS DESCRIBED HEREIN OR RELATED ITEMS CAN CAUSE DEATH, PERSONAL INJURY AND PROPERTY DAMAGE.

This document and other information from Parker Hannifin Corporation, its subsidiaries and authorized distributors provide product and/or system options for further investigation by users having technical expertise. It is important that you analyze all aspects of your application, including consequences of any failure and review the information concerning the product or systems in the current product catalog. Due to the variety of operating conditions and applications for these products or systems, the user, through its own analysis and testing, is solely responsible for making the final selection of the products and systems and assuring that all performance, safety and warning requirements of the application are met.

The products described herein, including without limitation, product features, specifications, designs, availability and pricing, are subject to change by Parker Hannifin Corporation and its subsidiaries at any time without notice.

EXTRA COPIES OF THESE INSTRUCTIONS ARE AVAILABLE FOR INCLUSION IN EQUIPMENT / MAINTENANCE MANUALS THAT UTILIZE THESE PRODUCTS. CONTACT YOUR LOCAL REPRESENTATIVE.

In-Service Lubrication:

Parker F442P oil is recommended. This is specially formulated to provide peak performance and maximum service life from all air operated equipment. Alternate compatible lubricants should be a paraffin based mineral oil having 150 to 200 SSU viscosity @ 100°F and an aniline point greater than 200°F. (Mobil DTE24 and Sun Company Sunvis 932 are good examples.)

⚠ CAUTION: Do not use synthetic, reconstituted, or oils with an alcohol content or detergent additives.

Symbols

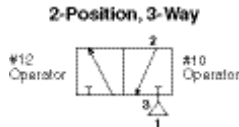

Note: For single solenoid or single air pilot operated valves, that operator is located on the 12 end for normally closed (NC) operation, and on the 10 end for normally open (NO) operation.

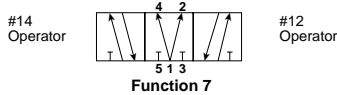
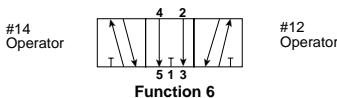
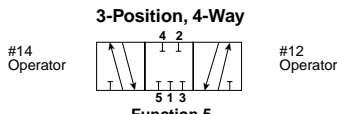
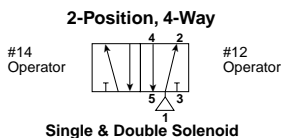

Port Identification

4-Way Service

Port No.	Function	
	Single Pressure	Dual Pressure
1	Inlet	Exhaust
2	Cylinder	Cylinder
3	Exhaust	Inlet
4	Cylinder	Cylinder
5	Exhaust	Inlet

NOTE: For valves specified for dual pressure, the highest pressure is to be at port #3.

4-Way valves may be used for 3-Way function by plugging an outlet port.

NOTE: The operator identification describes the ports that are connected when the operator is energized: operator 12 connects port 1 to port 2; operator 14 connects port 1 to port 4; port 1 is isolated when operator 10 is energized. Other ports may also be connected, or blocked – see symbols.

Wiring

Attach an electrical cable with connector (that conforms to the DIN 43650, Form C pattern) to the terminals of the solenoid. For locations in a cabinet or other protected environment, the Snap-On connector with loose wires may be attached. In both cases, do not attach or remove the connectors until power is off.

Follow all requirements for local and national electrical codes.

Electrical Connection:

Valves with 3-pin male terminals should have power connected to the parallel terminals. Ground should be connected to the perpendicular

terminal. Use only connectors that comply with DIN 43650, Form C (8mm blade spacing).

Accessories:

Kit No.	Description
PS298305P	Snap on Connector Kit with 0.5 meter wires
PS298320P	Snap on Connector Kit with 2 meter wires
PS2915P	Manifold End Plate Kit (4-Way valve)
PS2917P	Manifold <u>without</u> Flow Control Kit (4-Way valve)
PS2918P	Manifold with Flow Control Kit (4-Way valve)
PS2919P	Isolation Plug Kit
PS2920P	Inlet Block / Blanking Plate Kit (4-Way valve)
PS2932P	3-Pin Connector Kit - Unlighted
PS294675P	3-Pin Connector Kit - Lighted, 12VAC & DC
PS294679P	3-Pin Connector Kit - Lighted, 24VAC & DC
PS294683P	3-Pin Connector Kit - Lighted, 120VAC
PS2932JP	3-Pin Connector Kit - Unlighted with 2 meter cord
PS2946J75P	3-Pin Connector Kit - Lighted, 12VAC & DC with 2 meter cord
PS2946J79P	3-Pin Connector Kit - Lighted, 24VAC & DC with 2 meter cord
PS2946J83P	3-Pin Connector Kit - Lighted, 120VAC with 2 meter cord
PS2950P	IEM Manifold End Plate Kit (3-Way valve)
PS2952P	IEM Manifold End Plate Kit - External Pilot Supply (3-Way valve)
PS2948P	IEM Manifold <u>without</u> Flow Control Kit (3-Way valve)
PS2949P	IEM Manifold <u>with</u> Flow Control Kit (3-Way valve)
PS2968P	IEM Manifold Blanking Kit (3-Way valve)
PS2966P	IEM Manifold Intermediate Supply Kit (3-Way valve)

Service Kits Available

The following service kits contain the appropriate seals and parts necessary for ordinary field service.

Kit No.	Description
PS2901CP	2-Position body service kit (4-Way valve)
PS2902CP	3-Position all ports blocked body service kit (4-Way valve)
PS2903CP	3-Position cylinder to exhaust body service kit (4-Way valve)
PS2904CP	3-Position pressure center body service kit (4-Way valve)
PS2971P	Body Service Kit (3-Way valve)
PS2982AXX*P	Solenoid Kit - No Override
PS2982BXX*P	Solenoid Kit - Non-Locking Flush Override
PS2982CXX*P	Solenoid Kit - Locking Flush Override
PS2982DXX*P	Solenoid Kit - Non-Locking Extended Override
PS2982EXX*P	Solenoid Kit - Locking Extended Override

When ordering solenoid service kits specify two digit solenoid voltage code (XX) and if needed, interface relationship (*) to complete model number. Code keys are as given below:

XX - Voltage code key

Code	Voltage
40	12 Volt 60Hz, 12 Volt 50Hz
42	24 Volt 60Hz, 22 Volt 50Hz
45	12 Volt DC
49	24 Volt DC
53	120 Volt 60Hz, 115 Volt 50Hz

* Solenoid electrical pin and base interface relationship codes:

Blank	Solenoid pins up, opposite valve interface (standard location)
2	Solenoid pins down, on same side as valve interface



Pneumatic Division North America
 Richland, Michigan 49083

Service Instructions: V-401CP
2 & 3-Position Body and Operators
3-Way & 4-Way
“B3...C” Series Air Control Valves
1/8" Inline & 1/8" & 1/4" Subbase
ISSUED: May, 2001
Supersedes: March, 1999
ECN# P28222 Rev. 5

! WARNING

To avoid unpredictable system behavior that can cause personal injury and property damage:

- Disconnect electrical supply (when necessary) before installation, servicing, or conversion.
- Disconnect air supply and depressurize all air lines connected to this product before installation, servicing, or conversion.
- Operate within the manufacturer’s specified pressure, temperature, and other conditions listed in these instructions.
- Medium must be moisture-free if ambient temperature is below freezing.
- Service according to procedures listed in these instructions.
- Installation, service, and conversion of these products must be performed by knowledgeable personnel who understand how pneumatic products are to be applied.
- After installation, servicing, or conversion, air and electrical supplies (when necessary) should be connected and the product tested for proper function and leakage. If audible leakage is present, or the product does not operate properly, do not put into use.
- Warnings and specifications on the product should not be covered by paint, etc. If masking is not possible, contact your local representative for replacement labels.

Introduction

Follow these instructions to replace solenoids, remote air operators, return operator and main body spools in a “B3...C” valve.

Application Limits

These products are intended for use in general purpose compressed air systems only.

Operating Inlet Pressure:

	kPa	PSIG	bar
Min. (2-Position)	140	20	1.4
Min. (2-Position w/ Spring and Air Return)	240	35	2.4
Min. (3-Position)	210	30	2.1
Max. (2 & 3-Position)	1030	150	10.3

NOTE: Solenoid operated valves, when specified with external pilot, may have operating pressures down to vacuum in the main valve. External pilot pressure and air pilot signals must be greater than or equal to that in the main valve, but not outside the ratings above.

Ambient Temperature Range: -15°C to 49°C (5°F to 120°F)

Voltage Range: Rated Voltage +10%, -15%

Wiring

Attach an electrical cable with connector (that conforms to the DIN 43650, Form C pattern) to the terminals of the solenoid. For locations in a cabinet or other protected environment, the Snap-On connector with loose wires may also be attached. In both cases, do not attach or remove the connectors until power is off.

Follow all requirements for local and national electrical codes.

Accessories

Kit No	Description
PS298305P	Snap on Connector Kit with 0.5 meter wires
PS298320P	Snap on Connector with 2 meter wires
PS2915P	Manifold End Plate Kit (4-Way Valve)
PS2917P	Manifold <u>without</u> Flow Control Kit (4-Way Valve)
PS2918P	Manifold with Flow Control Kit (4-Way Valve)
PS2919P	Isolation Plug Kit (4-Way Valve)
PS291901P	Isolation Plug Kit (3-Way Valve)
PS2920P	Inlet Block/Blanking Plate Kit (4-Way Valve)
PS2932P	3-Pin Connector Kit - Unlighted
PS2948P	Manifold <u>without</u> Flow Control Kit (3-Way IEM)
PS2949P	Manifold <u>with</u> Flow Control Kit (3-Way IEM)
PS2950P	Manifold End Plate Kit (3-Way IEM)

Kit No	Description
PS2966P	Inlet Block/Blanking Plate Kit (3-Way IEM)
PS294675P	3-Pin Connector Kit - Lighted, 12VAC & DC
PS294679P	3-Pin Connector Kit - Lighted, 24VAC & DC
PS294683P	3-Pin Connector Kit - Lighted, 120VAC
PS2932JP	3-Pin Connector Kit - Unlighted with 2 meter cord
PS2946J75P	3-Pin Connector Kit - Lighted, 12VAC & DC with 2 meter cord
PS2946J79P	3-Pin Connector Kit - Lighted, 24VAC & DC with 2 meter wires
PS2946J83P	3-Pin Connector Kit - Lighted, 120VAC with 2 meter wires

Service Kits Available

The following service kits contain the appropriate seals and parts necessary for ordinary field service.

Kit No	Description
PS2901CP	2-Position body service kit (4-Way Valve)
PS2902CP	3-Position all ports blocked body service kit
PS2903CP	3-Position cylinder to exhaust body service kit
PS2904CP	3-Position pressure center body service kit
PS2971P	2-Position body service kit (3-Way Valve)
PS297103P	4-Way to dual 3/2 conversion kit - B3 NC
PS297104P	4-Way to dual 3/2 conversion kit - B3 NO
PS2982AXX*P	Solenoid Kit - No Override
PS2982BXX*P	Solenoid Kit - Non-Locking Flush Override
PS2982CXX*P	Solenoid Kit - Locking Flush Override
PS2982DXX*P	Solenoid Kit - Non-Locking Extended Override
PS2982EXX*P	Solenoid Kit - Locking Extended Override

When ordering solenoid service kits specify two digit solenoid voltage code (XX) and if needed, interface relationship (*) to complete model number. Code keys are as given below:

XX - Voltage code key

Code	Voltage
40	12 Volt 60Hz, 12 Volt 50Hz
42	24 Volt 60Hz, 22 Volt 50Hz
45	12 Volt DC
49	24 Volt DC
53	120 Volt 60Hz, 115 Volt 50Hz

- * Solenoid electrical pin and base interface relationship codes:
- Blank Solenoid pins up, opposite valve interface (standard location)
 - 2 Solenoid pins down, on same side as valve interface

! WARNING

FAILURE OR IMPROPER SELECTION OR IMPROPER USE OF THE PRODUCTS AND/OR SYSTEMS DESCRIBED HEREIN OR RELATED ITEMS CAN CAUSE DEATH, PERSONAL INJURY AND PROPERTY DAMAGE.

This document and other information from Parker Hannifin Corporation, its subsidiaries and authorized distributors provide product and/or system options for further investigation by users having technical expertise. It is important that you analyze all aspects of your application, including consequences of any failure and review the information concerning the product or systems in the current product catalog. Due to the variety of operating conditions and applications for these products or systems, the user, through its own analysis and testing, is solely responsible for making the final selection of the products and systems and assuring that all performance, safety and warning requirements of the application are met. The products described herein, including without limitation, product features, specifications, designs, availability and pricing, are subject to change by Parker Hannifin Corporation and its subsidiaries at any time without notice.

EXTRA COPIES OF THESE INSTRUCTIONS ARE AVAILABLE FOR INCLUSION IN EQUIPMENT / MAINTENANCE MANUALS THAT UTILIZE THESE PRODUCTS. CONTACT YOUR LOCAL REPRESENTATIVE.

Servicing Valve Body

1. Remove valve from its installation, either from its plumbing or from its subbase/manifold.
2. Remove solenoid assembly from the adapter by loosening the two screws (item 2) which secure the solenoid assembly to the solenoid adapter. Remove the seal (item 3) between solenoid and adapter. Remove the solenoid adapter from the main body by removing its two mounting screws.
- 3a. For 2-Position valves, remove an air operator and a return operator from the main body by removing their two mounting screws (item 5 and/or 15).
- 3b. For 3-Position valves, remove the air operators at each end from the main valve body if the valve is remote air operated.

NOTE: If servicing double solenoid or double air operated valve, instructions for solenoid or air operator apply to both ends of the valve - disregard references to air return operator.

4. Remove pistons (piston assemblies) from the solenoid adapter, air operator, or return operator. Remove the lip seals from the pistons.
5. Remove the seal (item 4) from the adapter or operator. Inspect piston bores for nicks, scratches, and surface imperfections - replace entire valve if these are found.
6. Push spool/seal assembly out of body and clean valve bore, taking care not to scratch bore. (If more aggressive cleaning is required, use mineral spirits or equivalent solvent and dry thoroughly). Inspect body's bore for nicks, scratches, or surface imperfections - replace entire valve if these are found.

NOTE: The presence of nicks, scratches and surface imperfections may reduce service life; thus, future replacement of entire valve should be planned if not replaced now.

7. Clean all parts which are going to be reused (such as seals and gaskets, pistons, piston bores, gasket tracks, etc.) with a lint free cloth. Apply fresh grease (provided) to all seals prior to reassembly.
8. Lightly grease seals on the new spool assembly and install it into valve bore. Take care to install spool squarely and push slowly to avoid damaging seals or the body's bore.
9. Lightly grease new seals (item 4) and install into solenoid adapter, air operator, or return operator grooves (see Figure 1).
10. Apply a light film of grease to operator piston bores and all surfaces of piston seals. Install seals onto piston with the lips of the seals facing the open end of the piston. (Depending on the type of valve being serviced, there will be extra piston seals.) Install the piston/seal assemblies into their operator bores, taking care to assure that the lips of the seals pass smoothly into the bores.
11. Reassemble the solenoid adapter, air operator, or return operator (to the same ends of the main body as before) using their two mounting screws - torque screws from 0.9 to 1.4 Nm (8 to 12 in-lbs). Install the solenoid interface seal (item 3) into its groove on the adapter and attach the solenoid assembly to the adapter using the two mounting screws; (see Figure 2 for torque values).

12. If valves were removed from their bases during repair, reassemble valve to base using proper gasket orientation. Reinstall the two socket head cap screws and tighten from 1.4 to 1.7 Nm (12 to 15 in-lbs) torque using a 2.5mm hex wrench.
13. Turn on air pressure and electrical power source. Test valve for functional operation and leakage (both internal and external). If leakage is audible (indicating improper repairs are likely), do not operate - conduct repairs again.

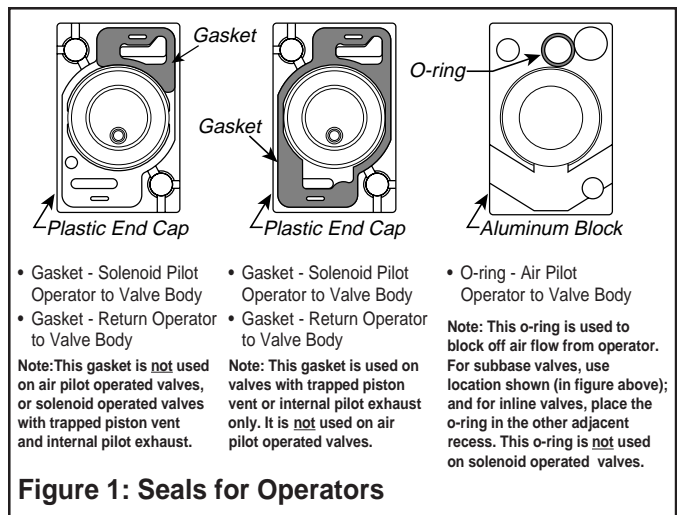

Part Identification List

Item #	Description
1	Solenoid Assembly
2	Solenoid Mounting Screws
3	Solenoid Interface Seal
4	Seal - adapter/operator to body (see Figure 1)
5	Mounting Screws - adapter to body (not shown)
6	Solenoid Adapter
7	Lip Seal - solenoid end or air operator
8	Piston (2-Position), Piston Assemblies (3-Position)
9	Spool Assembly
10	Main Valve Body
11	Piston - return operator end
12	Lip Seal - return operator end
13	Return Spring - (special option only)
14	Return Operator
15	Mounting Screws - return operator to body

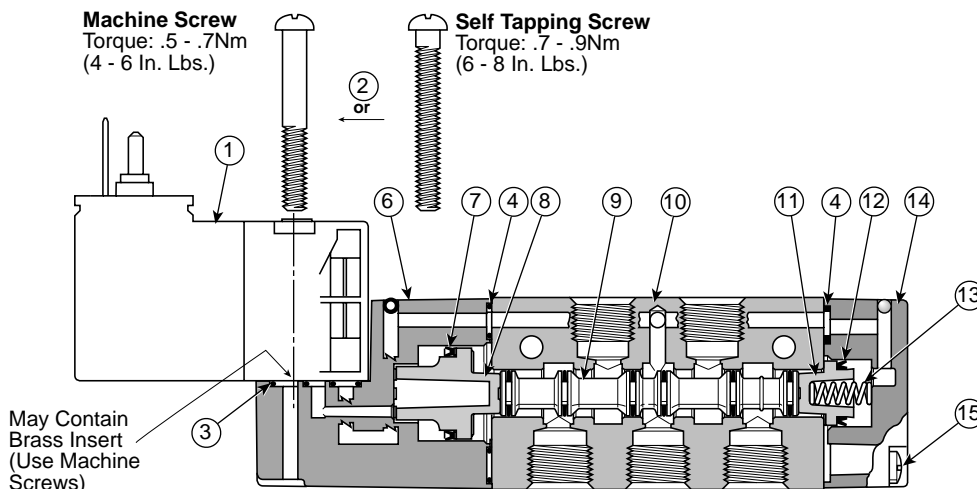

Figure 2: Single Solenoid Operated 4-Way Valve Illustrated (2-Position)



Pneumatic Division
Richland, Michigan 49083

Service Instructions:
V402EP

Solenoid Replacement Kits

ISSUED: June, 2015
Supersedes: September, 2011
Doc. #V-402P, EN #150415, Rev. J

⚠ WARNING

To avoid unpredictable system behavior that can cause personal injury and property damage:

- Disconnect electrical supply (when necessary) before installation, servicing, or conversion.
- Disconnect air supply and depressurize all air lines connected to this product before installation, servicing, or conversion.
- Operate within the manufacturer's specified pressure, temperature, and other conditions listed in these instructions.
- Medium must be moisture-free if ambient temperature is below freezing.
- Service according to procedures listed in these instructions.
- Installation, service, and conversion of these products must be performed by knowledgeable personnel who understand how pneumatic products are to be applied.
- After installation, servicing, or conversion, air and electrical supplies (when necessary) should be connected and the product tested for proper function and leakage. If audible leakage is present, or the product does not operate properly, do not put into use.
- Warnings and specifications on the product should not be covered by paint, etc. If masking is not possible, contact your local representative for replacement labels.

Safety Guide

For more complete information on recommended application guidelines, see the Safety Guide section of Pneumatic Division catalogs or you can download the **Pneumatic Division Safety Guide** at: www.parker.com/safety

Service Instructions

NOTE: See Figures for torque values.

1. After electrically de-energizing unit and relieving air pressure, remove the electrical connector. Remove snap-on type connector by squeezing the latches on the sides to disengage the latch tangs, then pull it off the solenoid (Item 1). If the snap-on connector is also held in place with a holding screw, this screw must be removed before the connector can be removed (see Figure 1). A cable plug requires unscrewing its holding screw from the center of the plug, then pulling it off of the solenoid (see Figure 2).
2. If several electrical connectors/cable plugs are removed, identify their locations to determine correct reconnection.
3. Remove the two screws or nut (Item 2) which secure the solenoid assembly to the solenoid adapter or operator, and remove the solenoid assembly (see Figure 1 & 3).
4. Inspect the surface of the solenoid adapter to be sure it is free of debris, that the seal (s) (Item 3) is not nicked or torn (replace with new seal in kit if in doubt), and that the seal is fully contained in its groove (see Figure 3).
5. Place the new solenoid assembly onto the surface of the solenoid adapter and fasten it in place with the two appropriate mounting screws or nut (Item 2). **15mm solenoid only:** If solenoid adapter contains brass inserts, use the machine screws. If solenoid adapter does not contain inserts, use the self tapping screws.
6. Replace the electrical connector using the previous identifications to correctly match solenoids and electrical connectors. When installing connector, engage the ground terminal first when pushing the connector onto the solenoid terminal.
To install a snap-on type connector, spread the side latch tangs and then push connector until the tangs engage. If high levels of vibration exist, or a taut connection is desired, connect the optional holding screw.
To install a cable plug, place the seal (Item 4) over the solenoid terminal before attaching the cable plug to the solenoid. Secure plug in place by inserting the holding screw through the plug's center hole, and then fastening it into the solenoid (Figure 2).
7. Apply main pressure and check for leaks. If any are present, do not operate the valve - repeat this process until satisfactory.

Wiring

Follow all requirements for local and national electrical codes.

Service Kits Available

The following service kits contain the appropriate seals and parts necessary for ordinary field service.

PS2982		B	40		P
Basic Kit Number					
PS2982	Standard Flow, Opp. Side, NC (B3)				
PS3201	Standard Flow, Same Side, NO (T1)				
PS3202	Standard Flow, Opp. Side, NO (T1)				
PS3441	Standard Flow, Same Side, NC (F3)				
PS3541	Hi Flow, Same Side, NC (F5) (Not available with 230/240 VAC)				
Override					
A	No Override				
B	Non-Locking Flush				
C	Locking Flush				
D	Non-Locking Extended				
E	Locking Extended				
6	30mm M12 (Euro), 2-pin				
Voltage					
40	12 VAC				
42	24 VAC				
45	12 VDC				
47	12 VDC Mobile (Not Available)				
48	24 VDC Mobile (Not Available)				
49	24 VDC				
51	48 VDC (Only available with kit number PS3541)				
53	115/120 VAC				
57	230/240 VAC (Not available with kit number PS3541)				
Fluorocarbon					
Blank	No Fluorocarbon				
V	Fluorocarbon (Not available with kit number PS3541)				
Label Suffix					
Blank	Generic				
P	Parker North America				

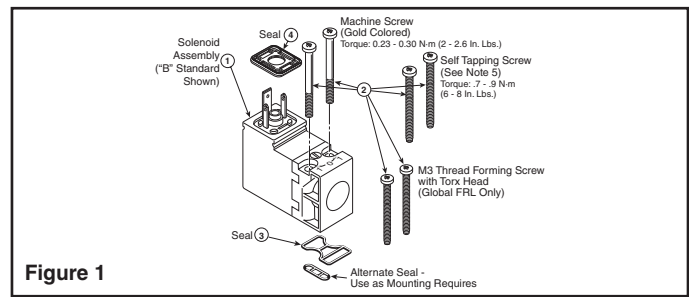

⚠ WARNING

FAILURE OR IMPROPER SELECTION OR IMPROPER USE OF THE PRODUCTS AND/OR SYSTEMS DESCRIBED HEREIN OR RELATED ITEMS CAN CAUSE DEATH, PERSONAL INJURY AND PROPERTY DAMAGE.

This document and other information from Parker Hannifin Corporation, its subsidiaries and authorized distributors provide product and/or system options for further investigation by users having technical expertise. It is important that you analyze all aspects of your application, including consequences of any failure and review the information concerning the product or systems in the current product catalog. Due to the variety of operating conditions and applications for these products or systems, the user, through its own analysis and testing, is solely responsible for making the final selection of the products and systems and assuring that all performance, safety and warning requirements of the application are met.

The products described herein, including without limitation, product features, specifications, designs, availability and pricing, are subject to change by Parker Hannifin Corporation and its subsidiaries at any time without notice.

EXTRA COPIES OF THESE INSTRUCTIONS ARE AVAILABLE FOR INCLUSION IN EQUIPMENT / MAINTENANCE MANUALS THAT UTILIZE THESE PRODUCTS. CONTACT YOUR LOCAL REPRESENTATIVE.

15mm Solenoid Replacement Kits

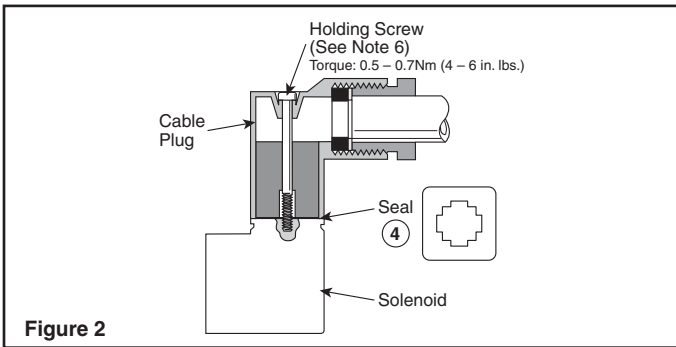

Connector	Connector with 6 foot cord (2 meters)	Description
PS2932P	PS2932JP	Unlighted
PS294675P	PS2946J75P	Light - 12VAC or 12VDC
PS294679P	PS2946J79P	Light - 24VAC or 24VDC
PS294683P	PS2946J83P	Light - 110 / 120VAC
PS294687P	N/A	Light - 240/230VAC

Female Electrical Connectors / Accessories

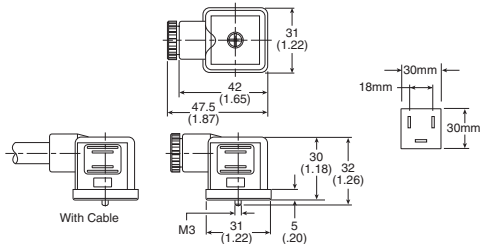

30x30 Square 3-Pin – ISO 4400, DIN 43650A (Use with Enclosure “A”)

Connector	Connector with 6' (2m) Cord	Description
PS2028BP	PS2028JCP	Unlighted
PS203279BP	PS2032J79CP*	Light – 6-48V, 50/60Hz, 6-48VDC
PS203283BP	PS2032J83CP*	Light – 120V/60Hz
PS203287BP	N/A	Light – 240V/60Hz

* LED with surge suppression.

Note: Max ø6.5mm cable size required for connector w/o 6' (2m) cord. IP65 rated when properly installed.

Engineering Data:

Conductors: 2 Poles Plus Ground; Cable Range (Connector Only): 8 to 10mm (0.31 to 0.39 Inch); Contact Spacing: 18mm

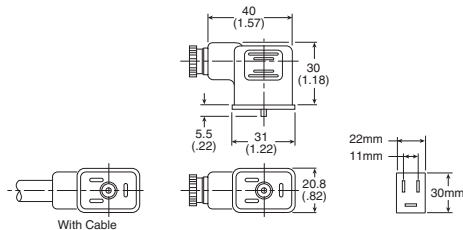

22x30 Rectangular 3-Pin – Type B Industrial (Use with Enclosure “B”)

Connector	Connector with 6' (2m) Cord	Description
PS2429BP	PS2429JBP	Unlighted
PS243079BP	PS2430J79BP*	Light – 24V60Hz, 24VDC
PS243083BP	PS2430J83BP*	Light – 120V/60Hz
PS243087BP	N/A	Light – 240V/60Hz

* LED with surge suppression.

Note: Max ø6.5mm cable size required for connector w/o 6' (2m) cord. IP65 rated when properly installed.

Engineering Data:

Conductors: 2 Poles Plus Ground; Cable Range (Connector Only): 6 to 8mm (0.24 to 0.31 Inch); Contact Spacing: 11mm

Solenoid Kits



Option A
30mm Square,
3-Pin ISO 4400, DIN 43650A



Option B
22mm Rectangular,
3-Pin DIN, Type B Industrial



Option G & Q (22mm)
Grommet, 18" or 72" Leads



Option H & R (22mm)
1/2" Conduit, 18" or 72" Leads

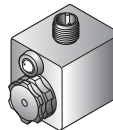

Option 6
M12 2-pin (30mm)

CNOMO Connection
2-Pin Male / Single Solenoid
(Encl. Option 6, Auto Option F)

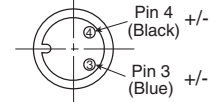

P2FC		A	4	49
Series				
P2FC	Solenoid Kit			
Coil Type				
A	30mm, 3-Pin, ISO Form A (Voltages: 42, 45, 47, 48, 49, 53, 57, 70, 71, 74, 77)			
B	22mm, 3-Pin, DIN43650B (Voltages: 42, 45, 47, 48, 49, 53, 57, 65)			
F	30mm, 3-Pin, Hazardous Duty (Voltages: 45, 49, 53, 57)			
G	22mm, 3-Pin, Grommet, 18" Leads (Voltages: 42, 45, 47, 48, 49, 53, 57)			
H	22mm, 3-Pin, Conduit, 18" Leads (Voltages: 42, 45, 47, 48, 49, 53, 57)			
Q	22mm, 3-Pin, Grommet, 2M Leads (Voltages: 42, 45, 47, 48, 49, 53, 57)			
R	22mm, 3-Pin, Conduit, 2M Leads (Voltages: 42, 45, 47, 48, 49, 53, 57)			
Power Level				
4	Power Level 4			
Voltage				
42	24 VAC	57	240 / 230 VAC	
45	12 VDC	65	75 VDC (Mobile)	
47	12 VDC (Mobile)	70	72 VDC (Mobile)	
48	24 VDC (Mobile)	71	96 VDC (Mobile)	
49	24 VDC	72	110 VDC (Mobile)	
51	48 VDC	74	48 VDC (Mobile)	
53	120 / 110 VAC	77	32 VDC (Mobile)	

Operator Kits

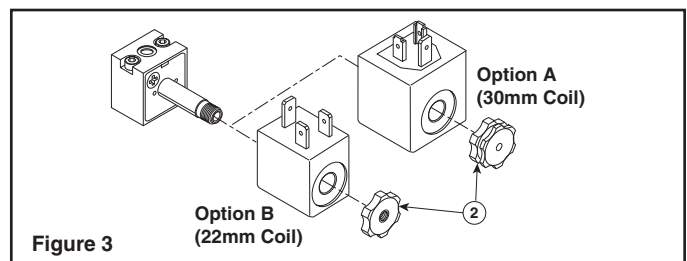

P2FP		1	3	N	4	C
Series						
P2FP	Pilot Operator Kit					
Base Type						
1	22x22MM (Not Shown)					
2	22x30MM, CNOMO					
Function						
3	3/2, Normally Closed					
Pressure / Temperature						
N	Standard, 10 bar, -10°C to 50°C					
H	Extreme, 16 bar, -30°C to 70°C (Override A or D Only)					
Power Level						
4	Power Level 4					
Overrides						
A	No Override					
C	Flush, Locking (Bistable), Plastic					
D	Extended, Non-Locking, (Monostable), Metal					



Pneumatic Division North America
 Richland, Michigan 49083

Installation and Operation
Instructions: V-420P

"B2...C" Series Air Control Valves
3-Way: Inline & Subbase
4-Way: Inline & Subbase

ISSUED: August, 2000
Supersedes: December, 1999
ECN# P27805

! WARNING

To avoid unpredictable system behavior that can cause personal injury and property damage:

- Disconnect electrical supply (when necessary) before installation, servicing, or conversion.
- Disconnect air supply and depressurize all air lines connected to this product before installation, servicing, or conversion.
- Operate within the manufacturer's specified pressure, temperature, and other conditions listed in these instructions.
- Medium must be moisture-free if ambient temperature is below freezing.
- Service according to procedures listed in these instructions.
- Installation, service, and conversion of these products must be performed by knowledgeable personnel who understand how pneumatic products are to be applied.
- After installation, servicing, or conversion, air and electrical supplies (when necessary) should be connected and the product tested for proper function and leakage. If audible leakage is present, or the product does not operate properly, do not put into use.
- Warnings and specifications on the product should not be covered by paint, etc. If masking is not possible, contact your local representative for replacement labels.

Introduction

Follow these instructions when installing, operating, or servicing the product.

Application Limits

These products are intended for use in general purpose compressed air systems only.

Operating Inlet Pressure:

	kPa	psig	bar
Min. (2-Position)	140	25	1.7
Min. (2-Position w/Spring and Air Return)	240	25	1.7
Min. (3-Position)	210	35	2.4
Max. (2 & 3-Position)	1030	150	10.3

NOTE: Solenoid operated valves, when specified with external pilot, may have operating pressures down to vacuum in the main valve. External pilot pressure and air pilot signals must be greater than or equal to that in the main valve, but not outside the ratings above.

Ambient Temperature Range: -7°C to 49°C (20°F to 120°F)

Voltage Range: Rated Voltage +10%, -15%

Installation Instructions

B2 valves should be installed with reasonable accessibility for service whenever possible; repair service kits are available. Keep pipe or tubing lengths to a minimum with inside clean and free of dirt and chips. Pipe joint compound should be used sparingly and

applied only to the male pipe - never into the female port. Do not use PTFE tape to seal pipe joints - pieces have a tendency to break off and lodge inside the unit, possibly causing malfunction. Care should be taken to avoid undue strain on the valve.

! CAUTION: An interruption of 10 milliseconds or greater to the power supplied to the solenoid of a solenoid operated valve may cause the valve to shift. Provision must be made to prevent power interruption of this duration to avoid unintended, potentially hazardous, consequences.

Air Quality - Air applied to the valve must be filtered to realize maximum component life.

! CAUTION: It is recommended that double operated 2-Position valves be mounted so that the axis of the main valve spool is in the horizontal plane. The valve may be rotated to any angle around the axis for mounting convenience.

Factory Pre-Lubrication - All valves are pre-lubricated at the factory. In-service lubrication is recommended. Valves will operate without added lubrication but with reduced service life.

Life Expectancy - Normal multimillion cycle life expectancy of these valves is based on the use of properly filtered and lubricated air at room temperature. These valves are also designed to operate under non-lubricated conditions and will yield millions of maintenance free cycles.

! WARNING

FAILURE OR IMPROPER SELECTION OR IMPROPER USE OF THE PRODUCTS AND/OR SYSTEMS DESCRIBED HEREIN OR RELATED ITEMS CAN CAUSE DEATH, PERSONAL INJURY AND PROPERTY DAMAGE.

This document and other information from Parker Hannifin Corporation, its subsidiaries and authorized distributors provide product and/or system options for further investigation by users having technical expertise. It is important that you analyze all aspects of your application, including consequences of any failure and review the information concerning the product or system in the current product catalog. Due to the variety of operating conditions and applications for these products or systems, the user, through its own analysis and testing, is solely responsible for making the final selection of the products and systems and assuring that all performance, safety and warning requirements of the application are met.

The products described herein, including without limitation, product features, specifications, designs, availability and pricing, are subject to change by Parker Hannifin Corporation and its subsidiaries at any time without notice.

EXTRA COPIES OF THESE INSTRUCTIONS ARE AVAILABLE FOR INCLUSION IN EQUIPMENT / MAINTENANCE MANUALS THAT UTILIZE THESE PRODUCTS. CONTACT YOUR LOCAL REPRESENTATIVE.

Manual Override:

A manual override (if supplied) is located on the body of the solenoid pilot, either on the same side or on the opposite side as the electrical terminals. A non-locking override is blue and must be twisted approx. 45° in either direction (and held at that position) in order to actuate the solenoid pilot. When released, the solenoid pilot will de-actuate. A flush type override requires use of a small screwdriver engaged in a slot on the end of the override button; a lever style override can be turned by finger. Locking overrides are yellow and must be twisted approx. 90° in either direction in order to actuate the solenoid pilot. They must be returned with a reverse twist to de-actuate. These are also either flush or extended types and operate as described above.

In-Service Lubrication:

In-service lubrication is not required; however, if lubrication is to be used, F442 oil is recommended. This oil is specially formulated to provide peak performance and maximum service life from all air operated equipment. Otherwise, use an air line lubricant (compatible with Nitrile seals) which will readily atomize and be of the medium aniline type. Aniline point range must be between 180° and 220° F. Viscosity at 100° F: 140 - 170 SUS.

CAUTION: Do not use synthetic, reconstituted, or oils with an alcohol content or detergent additives.

Symbols

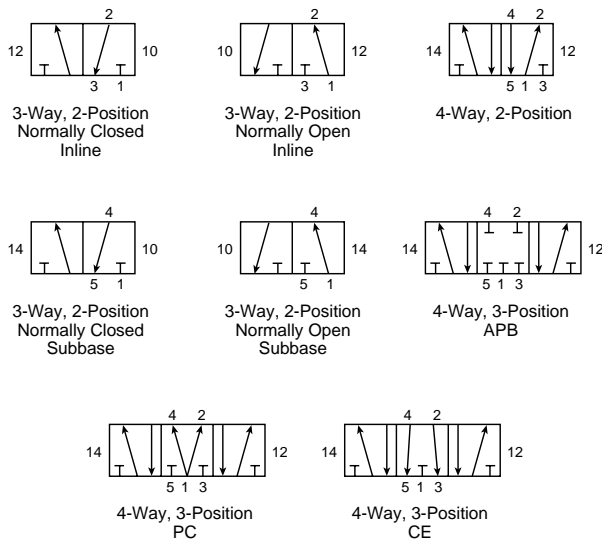

Port Identification

4-Way Service

Function

Port No.	Single Pressure
1	Inlet
2	Cylinder
3	Exhaust
4	Cylinder
5	Exhaust

4-Way valves may be used for 3-Way function by plugging an outlet port.

NOTE: The operator identification describes the ports that are connected when the operator is energized: operator 12 connects port 1 to port 2; operator 14 connects port 1 to port 4; port 1 is isolated when operator 10 is energized. Other ports may also be connected, or blocked – see symbols.

Wiring

Attach an electrical cable with connector (that conforms to the DIN 43650, Form C pattern) to the terminals of the solenoid. For locations in a cabinet or other protected environment, the Snap-On connector with loose wires may be attached. In both cases, do not attach or remove the connectors until power is off.

Follow all requirements for local and national electrical codes.

Electrical Connection:

Valves with 3-Pin male terminals should have power connected to the parallel terminals. Ground should be connected to the perpendicular terminal. Use only connectors that comply with DIN 43650, Form C (8mm blade spacing).

Accessories:

Kit No.	Description
PS298305P	Snap on Connector Kit with 0.5 meter wires
PS298320P	Snap on Connector Kit with 2 meter wires
PS2932P	3-Pin Connector Kit - Unlighted
PS294675P	3-Pin Connector Kit - Lighted, 12VAC & DC
PS294679P	3-Pin Connector Kit - Lighted, 24VAC & DC
PS294683P	3-Pin Connector Kit - Lighted, 120VAC
PS2932JP	3-Pin Connector Kit - Unlighted with 2 meter cord
PS2946J75P	3-Pin Connector Kit - Lighted, 12VAC & DC with 2 meter cord
PS2946J79P	3-Pin Connector Kit - Lighted, 24VAC & DC with 2 meter cord
PS2946J83P	3-Pin Connector Kit - Lighted, 120VAC with 2 meter cord
PS4486P	Valve to Base Gasket Kit
PS4487P	Inline Valve to Base Mounting Bolt Kit
PS4488P	Subbase Valve to Base Mounting Bolt Kit
PS4490P	Din Rail Hardware Kit IEM
PS4491P	Din Rail Hardware Kit Island
PS4494P	Blanking Plate Kit

Service Kits Available

The following service kits contain the appropriate seals and parts necessary for ordinary field service.

Kit No.	Description
PS4401P	Body Service Kit 4-Way 2-Position
PS4402P	Body Service Kit 3-Position APB
PS4403P	Body Service Kit 3-Position CE
PS4404P	Body Service Kit 3-Position PC
PS447100P	Body Service Kit 3-Way 2-Position Double Operated
PS447101P	Body Service Kit 3-Way 2-Position Normally Closed
PS447102P	Body Service Kit 3-Way 2-Position Normally Open
PS447103P	Body Service Kit 3-Way M8 Option Replacement for Eng. Level B

Solenoid Kits

Standard	“02” Option
PS2982B##P	PS3541B##P Flush - Non - Locking
PS2982C##P	PS3541C##P Flush - Locking
PS2982D##P	PS3541D##P Extended - Non - Locking
PS2982E##P	PS3541E##P Extended - Locking

##-Voltage Code

Override/Voltage Code Table	
Standard	“02” Option
B - 42, 45, 49, 53, 57	B - 42, 45, 49, 53, (57-PS3441B57P)
C - 42, 45, 49, 53, 57	C - 42, 45, 49, 53, (57-PS3441B57P)
D - 47, 48, 49, 53	D - 49, 53
E - 47, 48, 49, 53	E - 49, 53

Other instruction sheets available: V421P, V423P, and V402BP



Pneumatic Division North America
 Richland, Michigan 49083

Service Instructions: V-421P

2 & 3-Position Body and Operators
3-Way & 4-Way
“B2...C” Series Air Control Valves
M5 Inline & 1/8” Subbase

ISSUED: October, 1998
Supersedes: None
NPR: 6805

WARNING

To avoid unpredictable system behavior that can cause personal injury and property damage:

- Disconnect electrical supply before installation, servicing, or conversion.
- Disconnect air supply and depressurize all air lines connected to this product before installation, servicing, or conversion.
- Operate within the manufacturer’s specified pressure, temperature, voltage, and other conditions listed in these instructions.
- Medium must be moisture-free if ambient temperature is below freezing.
- Service according to procedures listed in these instructions.
- Installation, service, and conversion of these products must be performed by knowledgeable personnel who understand how pneumatic products are to be applied.
- After installation, servicing, or conversion, air and electrical supplies should be connected and the product tested for proper function and leakage. If audible leakage is present, or the product does not operate properly, do not put into use.
- Warnings and specifications on the product should not be covered by paint, etc. If masking is not possible, contact your local representative for replacement labels.

Introduction

Follow these instructions to replace solenoids, remote air operators, return operator and main body spools in a “B2...C” valve.

Application Limits

These products are intended for use in general purpose compressed air systems only.

Operating Inlet Pressure:

	kPa	PSIG	bar
Min. (2-Position)	140	25	1.7
Min. (2-Position w/Spring and Air Return)	240	25	1.7
Min. (3-Position)	210	35	2.4
Max. (2 & 3-Position)	1030	150	10.3

NOTE: Solenoid operated valves, when specified with external pilot, may have operating pressures down to vacuum in the main valve. External pilot pressure and air pilot signals must be greater than or equal to that in the main valve, but not outside the ratings above.

Ambient Temperature Range: -7°C to 50°C (20°F to 120°F)

Voltage Range: Rated Voltage +10%, -15%

Wiring

Attach an electrical cable with connector (that conforms to the DIN 43650, Form C pattern) to the terminals of the solenoid. For locations in a cabinet or other protected environment, the Snap-On connector with loose wires may also be attached. In both cases, do not attach or remove the connectors until power is off. Follow all requirements for local and national electrical codes.

Accessories:

<u>Kit No.</u>	<u>Description</u>
PS298305P	Snap on Connector Kit with 0.5 meter wires
PS298320P	Snap on Connector Kit with 2 meter wires
PS2932P	3-Pin Connector Kit - Unlighted
PS294675P	3-Pin Connector Kit - Lighted, 12VAC & DC
PS294679P	3-Pin Connector Kit - Lighted, 24VAC & DC
PS294683P	3-Pin Connector Kit - Lighted, 120VAC
PS2932JP	3-Pin Connector Kit - Unlighted with 2 meter cord
PS2946J75P	3-Pin Connector Kit - Lighted, 12VAC & DC with 2 meter cord
PS2946J79P	3-Pin Connector Kit - Lighted, 24VAC & DC with 2 meter cord
PS2946J83P	3-Pin Connector Kit - Lighted, 120VAC with 2 meter cord

Service Kits Available

The following service kits contain the appropriate seals and parts necessary for ordinary field service.

<u>Kit No.</u>	<u>Description</u>
PS4401P	Body Service Kit 4-Way 2-Position
PS4402P	Body Service Kit 3-Position APB
PS4403P	Body Service Kit 3-Position CE
PS4404P	Body Service Kit 3-Position PC
PS447100P	Body Service Kit 3-Way 2-Position Double Operated
PS447101P	Body Service Kit 3-Way 2-Position Normally Closed

WARNING

FAILURE OR IMPROPER SELECTION OR IMPROPER USE OF THE PRODUCTS AND/OR SYSTEMS DESCRIBED HEREIN OR RELATED ITEMS CAN CAUSE DEATH, PERSONAL INJURY AND PROPERTY DAMAGE.

This document and other information from Parker Hannifin Corporation, its subsidiaries and authorized distributors provide product and/or system options for further investigation by users having technical expertise. It is important that you analyze all aspects of your application, including consequences of any failure and review the information concerning the product or system in the current product catalog. Due to the variety of operating conditions and applications for these products or systems, the user, through its own analysis and testing, is solely responsible for making the final selection of the products and systems and assuring that all performance, safety and warning requirements of the application are met.

The products described herein, including without limitation, product features, specifications, designs, availability and pricing, are subject to change by Parker Hannifin Corporation and its subsidiaries at any time without notice.

EXTRA COPIES OF THESE INSTRUCTIONS ARE AVAILABLE FOR INCLUSION IN EQUIPMENT / MAINTENANCE MANUALS THAT UTILIZE THESE PRODUCTS. CONTACT YOUR LOCAL REPRESENTATIVE.

“B2...C” Series Air Control Valves (3-Way & 4-Way)

V-421P

PS447102P

Body Service Kit 3-Way 2-Position Normally Open

Solenoid Kits

Standard

“02” Option

PS2982B##P	PS3541B##P	Flush - Non - Locking
PS2982C##P	PS3541C##P	Flush - Locking
PS2982D##P	PS3541D##P	Extended - Non - Locking
PS2982E##P	PS3541E##P	Extended - Locking

##-Voltage Code

Override/Voltage Code Table

Standard

B - 42, 45, 49, 53, 57

C - 42, 45, 49, 53, 57

D - 47, 48, 49, 53

E - 47, 48, 49, 53

“02” Option

B - 42, 45, 49, 53, (57-PS3441B57P)

C - 42, 45, 49, 53, (57-PS3441C57P)

D - 49, 53

E - 49, 53

Servicing Valve Body

1. Remove valve from its installation, either from its plumbing or from its manifold.
2. Remove solenoid assembly from the adapter by loosening the two screws (item 2) which secure the solenoid assembly to the solenoid adapter. Remove the seal (item 3) between solenoid and adapter. Remove the solenoid adapter from the main body by removing its two mounting screws.
- 3a. For 2-Position valves, remove an air operator and a return operator from the main body by removing their two mounting screws (item 5 and/or 12). Two position (normally open and normally closed) valves do not have a return operator.
- 3b. For 3-Position valves, remove the air operators at each end from the main valve body if the valve is remote air operated.

NOTE: If servicing double solenoid or double air operated valve, instructions for solenoid or air operator apply to both ends of the valve - disregard references to air return operator.

4. Remove piston from the solenoid adapter, air operator. Remove the lip seal from the piston.
5. Remove the seal (item 4) from the adapter or operator. Inspect piston bores for nicks, scratches, and surface imperfections - replace entire valve if these are found.
6. Push spool/seal assembly out of body and clean valve bore, taking care not to scratch bore. (If more aggressive cleaning is required, use mineral spirits or equivalent solvent and dry thoroughly). Inspect body's bore for nicks, scratches, or surface imperfections - replace entire valve if these are found.

NOTE: The presence of nicks, scratches and surface imperfections may reduce service life; thus, future replacement of entire valve should be planned if not replaced now.

7. Clean all parts which are going to be reused (such as seals and gaskets, pistons, piston bores, gasket tracks, etc.) with a lint free cloth. Apply fresh grease (provided) to all seals prior to reassembly.
8. Lightly grease seals on the new spool assembly and install it into valve bore. Take care to install spool squarely and push slowly to avoid damaging seals or the body's bore.
9. Lightly grease new seals (item 4) and install into solenoid adapter, air operator, or return operator grooves (see Figure 1).
10. Apply a light film of grease to operator piston bores and all surfaces of piston seals. Install seals onto piston with the lips of the seals facing the open end of the piston. (Depending on the type of valve being serviced, there will be extra piston seals.) Install the piston/seal assemblies into their operator bores, taking care to assure that the lips of the seals pass smoothly into the bores.
11. Reassemble the solenoid adapter, air operator, or return operator (to the same ends of the main body as before) using their two mounting screws - torque screws from .28 to .36 N•m (8 to 12 in-oz). Install the solenoid interface seal (item 3) into its groove on the adapter and attach the solenoid assembly to the adapter using the two mounting screws; torque from .56 to .70 N•m (80 to 100 in-oz).
12. If valves were removed from their bases during repair, reassemble valve to base using proper gasket orientation. Reinstall the two socket head cap screws and tighten from .56 to .68 N•m (80 to 96 in-oz) torque using a 2.0 mm hex wrench.
13. Turn on air pressure and electrical power source. Test valve for functional operation and leakage (both internal and external). If leakage is audible (indicating improper repairs are likely), do not operate - conduct repairs again

Part Identification List

Item #	Description
1	Solenoid Assembly
2	Solenoid Mounting Screws
3	Solenoid Interface Seal
4	Seal - adapter/operator to body
5	Mounting Screws - adapter to body (not shown)
6	Solenoid Adapter
7	Lip Seal - solenoid end or air operator
8	Piston (2-Position)
9	Spool Assembly
10	Main Valve Body
11	Return Spring
12	Mounting Screws - return operator to body
13	Return Operator

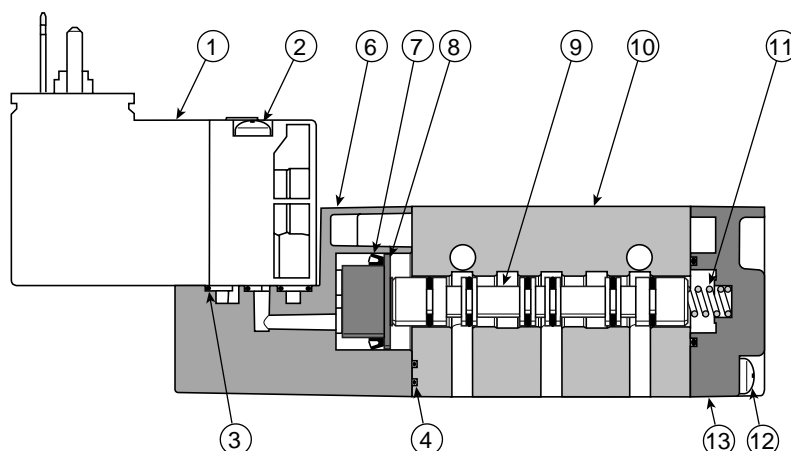



Pneumatic Division
Richland, Michigan 49083

Assembly Procedure: V423BP

**“B2...C” Series Valve
Extruded Manifolds**

**ISSUED: September, 2003
Supersedes: June, 2001**

DOC. #V-423BP, ECN# P030437, Rev. 3

⚠ WARNING

To avoid unpredictable system behavior that can cause personal injury and property damage:

- Disconnect electrical supply (when necessary) before installation, servicing, or conversion.
- Disconnect air supply and depressurize all air lines connected to this product before installation, servicing, or conversion.
- Operate within the manufacturer’s specified pressure, temperature, and other conditions listed in these instructions.
- Medium must be moisture-free if ambient temperature is below freezing.
- Service according to procedures listed in these instructions.
- Installation, service, and conversion of these products must be performed by knowledgeable personnel who understand how pneumatic products are to be applied.
- After installation, servicing, or conversion, air and electrical supplies (when necessary) should be connected and the product tested for proper function and leakage. If audible leakage is present, or the product does not operate properly, do not put into use.
- Warnings and specifications on the product should not be covered by paint, etc. If masking is not possible, contact your local representative for replacement labels.

Introduction

Follow these instructions when installing and operating the product.

Application Limits

These products are intended for use in general purpose compressed air systems only. Compliance with the rated pressure, temperature and voltage is necessary — see installation instructions packed with (or label on) valve.

Operating Pressure Range

	kPa	PSIG	bar
Minimum (Double Remote and Externally Piloted Single or Double Solenoid)	VACUUM		
Minimum (3-Position Internally Piloted Double Solenoid)	207	35	2.4
Maximum	1000	145	10.0

Ambient Temperature Range: -7°C to 50°C (20°F to 120°F)

Note: The above ratings are those of the associated valve.

Manifold Application

Valves may be manifolded from 2 to 20 stations, providing that sufficient pressure is realized in the circuits downstream of the valve outlets; and sufficient pressure is available for shifting the valves. Means to increase pressure levels include supply connections at both ends of the manifold and sequencing the valve operation to maximize time between different valve shifts.

⚠ WARNING: Air exhausting from one valve into the exhaust gallery of the manifold may pressure other valve circuits open to the same gallery. Design the circuit such that there is no hazard or damage consequence from this action.

Port Connections

The manifold has an Inlet and Exhaust port(s) on each end. The inlet air can be supplied to one or both ends of the manifold, and the exhaust air can be released through one or both ends of the manifold.

Port No.	Function	Port No.	Function
3/2 IEM		5/2 & 5/3	
1	Inlet	1	Inlet
2	Cylinder	2	Cylinder
5*	Exhaust	3	Exhaust
X	External Pilot	4	Cylinder
3/2 Subbase		5	Exhaust
1	Inlet	X	External Pilot
4	Cylinder		
5	Exhaust		
X	External Pilot		

- Valve decal is marked with a “3” at this location although it is connected to the “5” gallery of the manifold. This is because the valves used on IEM (Inlet Exhaust Manifolds) are also sold separately as line mounting valves.

Valve Mounting Procedures

- 1) Clean top surface of manifold and bottom surface of valve body of any dirt or dust.
- 2) Assemble gasket to bottom of valve. Make sure pilot holes in gasket are aligned with pilot holes in body. Internally piloted inline valves do not have pilot holes.
- 3) Place the valve and gasket assembly on top of the manifold. Make sure pilot holes in gasket are aligned with pilot holes in manifold.
- 4) Tighten the two mounting screws until the head of each screw touches the valve body. Tighten each screw approximately 2-3 in.lbs. Finish torquing each screw to 7-10 in.lbs.
- 5) Repeat steps 1 - 4 for each subsequent valve on the manifold.

⚠ WARNING

FAILURE OR IMPROPER SELECTION OR IMPROPER USE OF THE PRODUCTS AND/OR SYSTEMS DESCRIBED HEREIN OR RELATED ITEMS CAN CAUSE DEATH, PERSONAL INJURY AND PROPERTY DAMAGE.

This document and other information from Parker Hannifin Corporation, its subsidiaries and authorized distributors provide product and/or system options for further investigation by users having technical expertise. It is important that you analyze all aspects of your application, including consequences of any failure and review the information concerning the product or systems in the current product catalog. Due to the variety of operating conditions and applications for these products or systems, the user, through its own analysis and testing, is solely responsible for making the final selection of the products and systems and assuring that all performance, safety and warning requirements of the application are met.

The products described herein, including without limitation, product features, specifications, designs, availability and pricing, are subject to change by Parker Hannifin Corporation and its subsidiaries at any time without notice.

EXTRA COPIES OF THESE INSTRUCTIONS ARE AVAILABLE FOR INCLUSION IN EQUIPMENT / MAINTENANCE MANUALS THAT UTILIZE THESE PRODUCTS. CONTACT YOUR LOCAL REPRESENTATIVE.

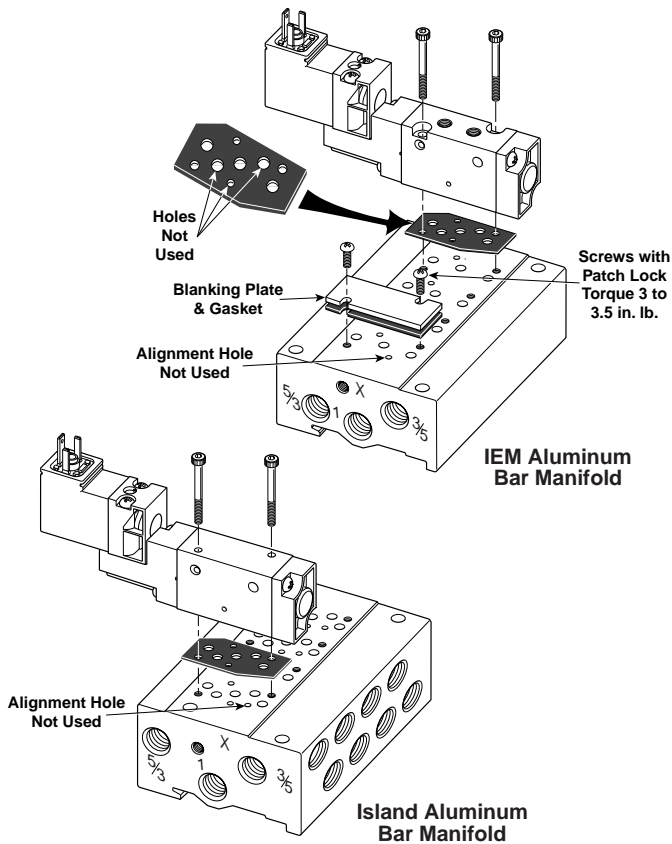

Internal / External Pilot Conversion

To convert Subbase Manifolds from internal pilot supply to external pilot supply:

- 1) Remove one M5 plug from "X" port in end of manifold.
- 2) Remove 1/8" pipe plug from top of manifold.
- 3) Install M5 plug in M5 port uncovered by removing 1/8" pipe plug.
- 4) Reinstall 1/8" pipe plug into top of manifold.
- 5) Connect external pilot supply to "X" port in end of manifold.

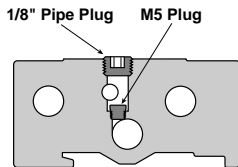

External Pilot Supply Configuration Shown

IEM (Inlet Exhaust Manifolds) - Conversion is not required. Purchase externally pilot supply valves and connect external pilot supply to "X" port in end of manifold.

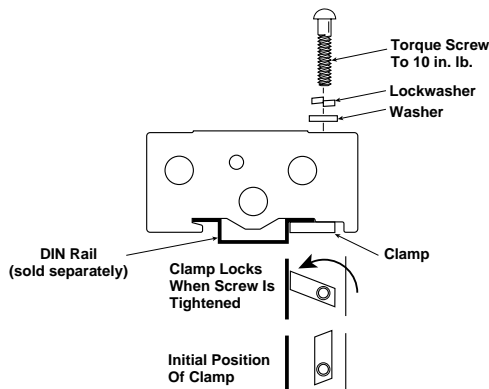

DIN Rail Assembly

Install 35mm DIN Rail Kit as shown above. Each Clamp must be installed as shown so that the cam action will lock the manifold onto the DIN Rail.

Wiring Instructions

NOTE: In addition to the following instructions, follow all requirements for local and national electrical codes.

Attach an electrical cable with connector (that conforms to the DIN 43650, Form C pattern) to the terminals of the solenoid. For locations in a cabinet or other protected environment, the Snap-On connector with loose wires may be attached. In both cases, do not attach or remove the connectors until power is off.

Electrical Connection

Valves with 3-Pin male terminals should have power connected to the parallel terminals. Ground should be connected to the perpendicular terminal. Use only connectors that comply with DIN 43650, Form C (8mm blade spacing).

Accessories

Kit No.	Description
PS4486P	Valve to Base Gasket Kit
PS4487P	Inline Valve to Base Mounting Bolt Kit
PS4488P	Subbase Valve to Base Mounting Bolt Kit
PS4490P	DIN Rail Hardware Kit IEM
PS4491P	DIN Rail Hardware Kit Island Manifold
PS4494P	Blanking Plate Kit
PS298305P	Snap on Connector Kit with 0.5 Meter Wires
PS298320P	Snap on Connector Kit with 2 Meter Wires
PS2932P	3-Pin Connector Kit - Unlighted
PS294675P	3-Pin Connector Kit - Lighted, 12VAC & DC
PS294679P	3-Pin Connector Kit - Lighted, 24VAC & DC
PS294683P	3-Pin Connector Kit - Lighted, 120VAC
PS2932JP	3-Pin Connector Kit - Unlighted with 2 Meter Cord
PS2946J75P	3-Pin Connector Kit - Lighted, 12VAC & DC with 2 Meter Cord
PS2946J79P	3-Pin Connector Kit - Lighted, 24VAC & DC with 2 Meter Wires
PS2946J83P	3-Pin Connector Kit - Lighted, 120VAC with 2 Meter Wires

Service Kits Available

The following service kits contain the appropriate seals and parts necessary for ordinary field service.

Kit No.	Description
PS4401P	2-Position Body Service Kit (4-Way Valve)
PS4402P	3-Position All Ports Blocked Body Service Kit
PS4403P	3-Position Cylinder to Exhaust Body Service Kit
PS4404P	3-Position Pressure Center Body Service Kit
PS447100P	2-Position Body Service Kit (3-Way Double Solenoid/Double Pilot)
PS447101P	2-Position Body Service Kit (3-Way Normally Closed)
PS447102P	2-Position Body Service Kit (3-Way Normally Open)

Solenoid Kits

Standard	"02" Option
PS2982B##P	PS3541B##P
PS2982C##P	PS3541C##P
PS2982D##P	PS3541D##P
PS2982E##P	PS3541E##P

- Voltage Code

Override / Voltage Code Table

Standard	"02" Option
B - 42, 45, 49, 53, 57	B - 42, 45, 49, 53, (57 - PS3441B57P)
C - 42, 45, 49, 53, 57	C - 42, 45, 49, 53, (57 - PS3441C57P)
D - 47, 48, 49, 53	D - 49, 53
E - 47, 48, 49, 53	E - 49, 53



Pneumatic Division North America
 Richland, Michigan 49083

Installation & Service Instructions
V-425P

B2 Sandwich Regulator

ISSUED: February, 2003
Supersedes: August, 2000

ECN# 030108

⚠ WARNING

To avoid unpredictable system behavior that can cause personal injury and property damage:

- Disconnect electrical supply (when necessary) before installation, servicing, or conversion.
- Disconnect air supply and depressurize all air lines connected to this product before installation, servicing, or conversion.
- Operate within the manufacturer's specified pressure, temperature, and other conditions listed in these instructions.
- Medium must be moisture-free if ambient temperature is below freezing.
- Service according to procedures listed in these instructions.
- Installation, service, and conversion of these products must be performed by knowledgeable personnel who understand how pneumatic products are to be applied.
- After installation, servicing, or conversion, air and electrical supplies (when necessary) should be connected and the product tested for proper function and leakage. If audible leakage is present, or the product does not operate properly, do not put into use.
- Warnings and specifications on the product should not be covered by paint, etc. If masking is not possible, contact your local representative for replacement labels.

Introduction

Follow these instructions when installing, operating, or servicing the product.

Application Limits

These products are intended for use in general purpose compressed air systems only.

Operating Inlet Pressure:	kPa	psig	bar
Maximum	1034	150	10.34

Ambient Temperature Range: 0°C to 52°C (32°F to 125°F)

Voltage Range: +10 to -15% of rating
 (Applicable only for solenoid operated valves)

NOTE: Some of the above ratings are those of the associated valve.

Common Port Regulator with 4-Way, 2-Position Valve

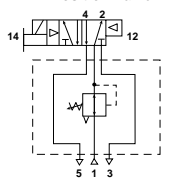

Independent Port Regulator with 4-Way, 3-Position All Ports Blocked Valve

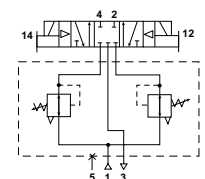

Independent Port Regulator with 4-Way, 3-Position, Inlet to Cylinder Function

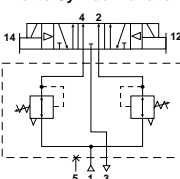

⚠ CAUTION: Requires 4-Way, 3-Position, Cylinder to Exhaust Valve

Independent Port Regulator with 4-Way, 3-Position, Cylinder to Exhaust Function

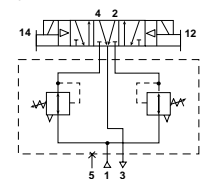

⚠ CAUTION: Requires 4-Way, 3-Position, Inlet to Cylinder Valve

* Marfak MP-2 is a registered trademark of Texaco.

Installation & Operating Instructions

A sandwich regulator is used to provide regulated pressure to individual valves in a manifolded valve arrangement. Two basic modes of regulation are available as follows:

Common Port Regulation - Provides adjustable regulated air pressure to the valve inlet.

Independent Port Regulation - Provides (2) separately adjustable regulated air pressures, one to each of the valves exhaust passages. The valves exhaust (coming out of its inlet passage) is directed to manifold or subbase exhaust port "3"

⚠ CAUTION: The reverse valve porting utilized with Independent Port Regulation will reverse the function of 4-Way, 3-Position cylinder to exhaust and 4-Way, 3-Position inlet to cylinder valves. Utilize the opposite function valve for normal operation.

Sandwich regulator should be installed with reasonable accessibility for service whenever possible. Repair service kits are available. Keep pipe or tubing lengths to a minimum with inside clean and free of dirt and chips. Pipe joint compound should be used sparingly and applied only to the male pipe, never into the female port. Do not use PTFE tape to seal pipe joints. Pieces have a tendency to break off and lodge inside the unit, possibly causing malfunction.

Air applied to the sandwich regulator must be filtered to realize maximum component life.

Factory Pre-Lubrication - Sandwich regulators are pre-lubricated at assembly with Marfak MP-2* grease.

⚠ CAUTION: Do not use synthetic, reconstituted, or oils with an alcohol content or detergent additive.

⚠ WARNING

FAILURE OR IMPROPER SELECTION OR IMPROPER USE OF THE PRODUCTS AND/OR SYSTEMS DESCRIBED HEREIN OR RELATED ITEMS CAN CAUSE DEATH, PERSONAL INJURY AND PROPERTY DAMAGE.

This document and other information from Parker Hannifin Corporation, its subsidiaries and authorized distributors provide product and/or system options for further investigation by users having technical expertise. It is important that you analyze all aspects of your application, including consequences of any failure and review the information concerning the product or systems in the current product catalog. Due to the variety of operating conditions and applications for these products or systems, the user, through its own analysis and testing, is solely responsible for making the final selection of the products and systems and assuring that all performance, safety and warning requirements of the application are met.

The products described herein, including without limitation, product features, specifications, designs, availability and pricing, are subject to change by Parker Hannifin Corporation and its subsidiaries at any time without notice.

EXTRA COPIES OF THESE INSTRUCTIONS ARE AVAILABLE FOR INCLUSION IN EQUIPMENT / MAINTENANCE MANUALS THAT UTILIZE THESE PRODUCTS. CONTACT YOUR LOCAL REPRESENTATIVE.

Installation

1. Place one gasket on top of subbase or manifold lining up all holes.
2. Place Sandwich Regulator on top of gasket, lining up bolt holes and pilot supply drillings.
3. Place second gasket on top of Sandwich Regulator lining up all holes.
4. Place valve on top of second gasket, lining up bolt holes and pilot supply drillings.
5. Assemble valve and Sandwich Regulator with (2) hex head screws. Tighten screws to .9 to 1.1Nm (8 - 10 in-lb) torque using 4mm socket or wrench.

Note: If assembling multiple Sandwich Regulators side by side assemble all units before tightening hex head screws.

6. Apply pressure to subbase or manifold and check for audible leakage at joints. If any are present, do not operate the valve. Repeat the assembly procedure until satisfied.
7. Adjust outlet pressure per Outlet Pressure Adjustment procedure to verify proper function.

Gauge Installation

(Common Port Regulator Version):

Gauge installation requires differing combinations of fittings depending on the sandwich regulators position on the manifold. View the manifold facing the #2 and #4 cylinder ports. The first station from the left will be considered station #1. Use the following guide to choose gauge fittings:

Station #1: Screw gauge directly into port.

Station #N: Screw in a 215PNL-2-15 nipple, a 2201P-2-2 45° elbow and the gauge.

Station #N+1: Screw in a 215PNL-2-15 nipple, a 207P-2 coupling and the gauge.

Alternate between the N and N+1 combinations for additional stations.

Apply pipe sealant to male threads of gauge and all fittings prior to installation.

Outlet Pressure Adjustment

1. Before turning on the air supply, turn the adjusting knob counterclockwise until compression is released from the pressure control spring then turn on air supply. Proceed to adjust the desired downstream pressure by turning adjusting knob clockwise. This permits pressure to build up slowly in the downstream line.
2. To decrease regulated pressure setting, always reset from a pressure lower than the final setting required. Example, lowering the secondary pressure from 550 kPa (80 PSIG) to 410 kPa (60 PSIG) is best accomplished by dropping the secondary pressure to 345 kPa (50 PSIG), then adjusting upward to 410 kPa (60 PSIG).

Service Instructions

1. Disconnect air supply and depressurize the unit.
2. Loosen nut on adjusting screw. Turn adjusting screw counterclockwise until all downstream air is exhausted.
3. Remove regulator cartridge from block and replace with a new unit.
4. Reapply pressure to unit and check for audible leakage at joints or out bleed holes. If any are present, do not operate the valve. Repeat assembly procedure until satisfied.
5. Adjust outlet pressure per *Outlet Pressure Adjustment* procedure.

Replacement Parts

Item No.	Part Number	Description
A	PS299922P PS299933P	Regulator Cartridge, 60 PSI Regulator Cartridge, 125 PSI
B	K183125	Gasket, Body / Base

Replacement Gauge

PSI	Standard
0 - 160	PS3451160P

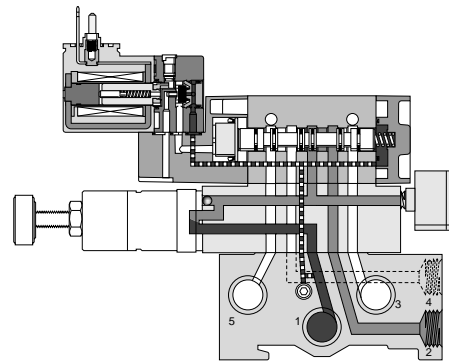
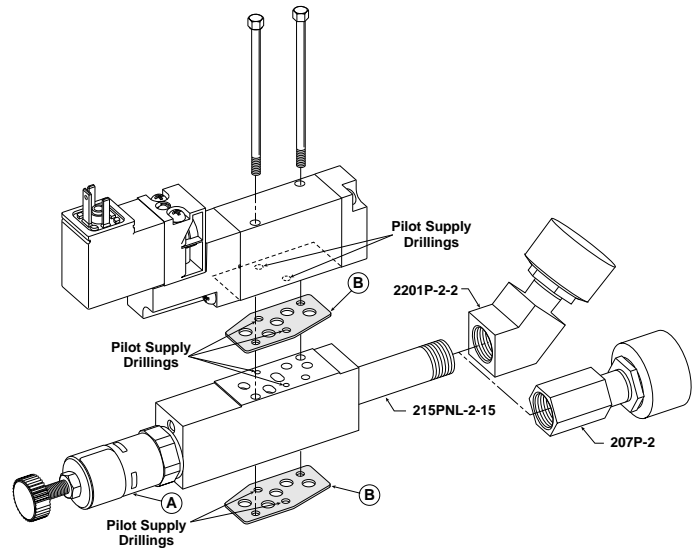

Common Port Sandwich Regulator

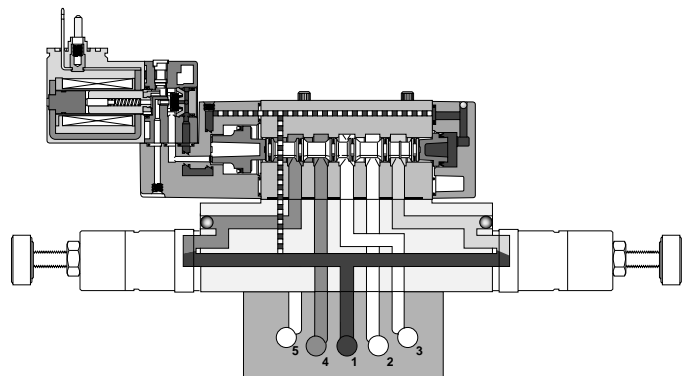

Dual Port Sandwich Regulator



Pneumatic Division
 Richland, Michigan 49083

Installation & Service Instructions
V-510FP
B6, B7, B8 Series Air Control Valves
3/8", 1/2", 3/4" Inline
ISSUED: March, 2005
Supersedes: May, 2002
DOC# V510P, ECN# 050248 Rev. 6

⚠ WARNING

To avoid unpredictable system behavior that can cause personal injury and property damage:

- Disconnect electrical supply (when necessary) before installation, servicing, or conversion.
- Disconnect air supply and depressurize all air lines connected to this product before installation, servicing, or conversion.
- Operate within the manufacturer's specified pressure, temperature, and other conditions listed in these instructions.
- Medium must be moisture-free if ambient temperature is below freezing.
- Service according to procedures listed in these instructions.
- Installation, service, and conversion of these products must be performed by knowledgeable personnel who understand how pneumatic products are to be applied.
- After installation, servicing, or conversion, air and electrical supplies (when necessary) should be connected and the product tested for proper function and leakage. If audible leakage is present, or the product does not operate properly, do not put into use.
- Warnings and specifications on the product should not be covered by paint, etc. If masking is not possible, contact your local representative for replacement labels.

Introduction

Follow these instructions when installing, operating, or servicing the product.

Application Limits

These products are intended for use in general purpose compressed air systems only.

2-Position Operating Pressure:

	B6			B7 / B8		
	kPa	PSIG	bar	kPa	PSIG	bar
Minimum	138	20	1.4	207	30	2.0
Maximum	1030	145	10.0	1030	145	10.0

3-Position Operating Pressure:

	B6			B7 / B8		
	kPa	PSIG	bar	kPa	PSIG	bar
Minimum	207	30	2.0	310	45	3.0
Maximum	1030	145	10.0	1030	145	10.0

NOTE: Solenoid operated valves specified for external pilot or double air pilot operated valves may have pressures down to vacuum in the main valve. External pilot pressure and air pilot signals must be greater than or equal to that in the main valve, but not exceed the ranges above.

Ambient Temperature Range: -15°C to 49°C (5°F to 120°F)

Voltage Range: Rated Voltage +10% / -15%

Lubrication

Filtered and lubricated air is necessary for maximum valve life and minimum maintenance. If in-service lubrication is used, lubricate with a straight paraffin based mineral oil having an ISO viscosity grade of 32 (e.g. Sunvis 932).

NOTE: Once in-service lubrication is initiated, the practice should be continued in order to maximize valve life.

Maintenance & Trouble Shooting Hints

Valve Not Shifting Completely When Energized:

1. Check to insure that the proper voltage is supplied to the solenoids.
2. Check to insure that the minimum supply pressure is equal to that shown in the Application Limits chart above.
3. Check for possible restrictions in air supply, such as undersized hoses, fittings, or quick disconnects.
4. Check to insure that the spool moves smoothly.
5. Check spool seals for proper installation, dirt, or damage.

Air Leakage Through Exhaust Ports:

1. Check for internal leakage in the cylinder being operated by the valve.
2. Check condition of the spool seals for proper alignment, damaged (nicked or broken) seals and dirt contamination.
3. Check for missing, damaged, or incorrectly assembled o-rings and gaskets.

If installing new spool: Remove old spool assembly, taking care not to scratch bore. Install new spool assembly into clean bore, taking care to install squarely and push slowly to avoid damaging seals or the valve bore.

If installing new piston: Refer to drawing for proper orientation. Install piston/seal assembly into the operator bore, taking care to assure the lips of the seal pass smoothly into the bore.

⚠ Lightly grease with provided lubricant.

✓ Inspect for nicks, scratches, and surface imperfections. If present, reduced service life is probable and future replacement should be planned.

Ⓒ Clean with lint-free cloth.

* If more aggressive cleaning is required, use mineral spirits or equivalent solvent and dry thoroughly.

General Installation & Operating Instructions

Valve should be installed with reasonable accessibility for service whenever possible. Repair service kits are available. Keep pipe or tubing clean and free of dirt and chips. Pipe joint compound should be used sparingly and applied only to the male pipe - never into the female port. Do not use PTFE tape to seal pipe joints - pieces have a tendency to break off and lodge inside the unit, possibly causing malfunction. After valve assembly is complete, plumb the valve, turn on air pressure and electrical power source. Test valve for functional operation and internal and external leakage. If leakage is audible (indicating improper assembly is likely), do not operate. Conduct assembly again.

Service Kits Available:

The following service kits contain the appropriate seals and parts necessary for ordinary field service. Consult local representative for kits not listed.

B6	B7 / B8	Description
PS2601P	PS2501P	2-Position body service kit, 4-Way
PS2602P	PS2502P	3-Position all ports blocked body service kit
PS2603P	PS2503P	3-Position cylinder to exhaust body service kit
PS2604P	PS2504P	3-Position pressure center body service kit
PS267101P	PS257101P	Body service kit, 3-Way, NC
PS267102P	PS257102P	Body service kit, 3-Way, NO

Service Instruction Sheets

- V-513P Manifold & accessory instruction sheet
- V-402P 15mm Solenoid Replacement Kits

⚠ WARNING

FAILURE OR IMPROPER SELECTION OR IMPROPER USE OF THE PRODUCTS AND/OR SYSTEMS DESCRIBED HEREIN OR RELATED ITEMS CAN CAUSE DEATH, PERSONAL INJURY AND PROPERTY DAMAGE.

This document and other information from Parker Hannifin Corporation, its subsidiaries and authorized distributors provide product and/or system options for further investigation by users having technical expertise. It is important that you analyze all aspects of your application, including consequences of any failure and review the information concerning the product or systems in the current product catalog. Due to the variety of operating conditions and applications for these products or systems, the user, through its own analysis and testing, is solely responsible for making the final selection of the products and systems and assuring that all performance, safety and warning requirements of the application are met.

The products described herein, including without limitation, product features, specifications, designs, availability and pricing, are subject to change by Parker Hannifin Corporation and its subsidiaries at any time without notice.

EXTRA COPIES OF THESE INSTRUCTIONS ARE AVAILABLE FOR INCLUSION IN EQUIPMENT / MAINTENANCE MANUALS THAT UTILIZE THESE PRODUCTS. CONTACT YOUR LOCAL REPRESENTATIVE.

Wiring

Follow all requirements for local and national electrical codes.

Electrical Connection:

1. Valve with lead wires should have power connected to the black wires. Ground should be connected to the green wire if provided.
2. Valves with 3-Pin male terminals should have power connected to the parallel terminals. Ground should be connected to the perpendicular terminal.
3. Valves with Mini Automotive Connector:
 - A. 3-Pin; power should be connected to #2 and #3 terminals. Ground should be connected to #1 terminal.
 - B. 5-Pin; power should be connected to #1 and #5 terminals. Ground should be connected to #3 terminal.

Installation

CAUTION: It is recommended that double operated 2-Position valves be mounted so that the axis of the main valve spool is in the horizontal plane. The valve may be rotated 360° around the axis for mounting convenience.

Symbols

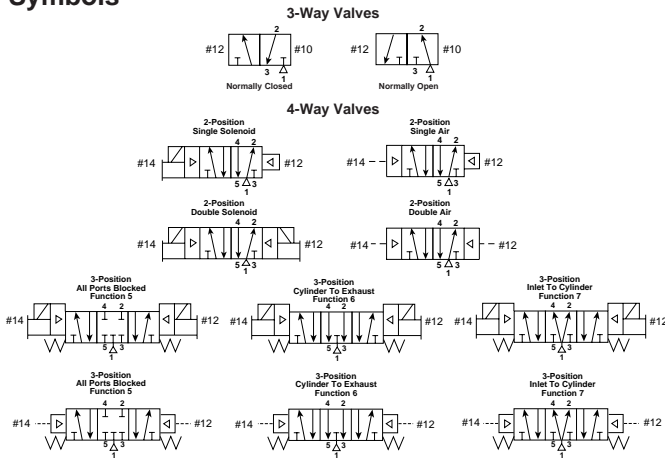

Port Identification
3-Way Valves

Port No.	Function
1	Inlet
2	Cylinder
3	Exhaust

4-Way Valves

Port No.	Function	
	Single Pressure	Dual Pressure
1	Inlet	Exhaust
2	Cylinder	Cylinder
3	Exhaust	Inlet
4	Cylinder	Cylinder
5	Exhaust	Inlet

NOTE: For valves specified for dual pressure, the higher pressure is to be at port #3. 4-Way valves may be used for 3-Way function by plugging an outlet port.

NOTE: For single pressure valves, the operator nearest a cylinder port causes that cylinder port to be pressurized, when that operator is in control of the valve.

XX	Voltage Code
42	24VAC
45	12VDC
47	12VDC Mobile
48	24VDC Mobile
49	24VDC
53	120VAC
57	240VAC

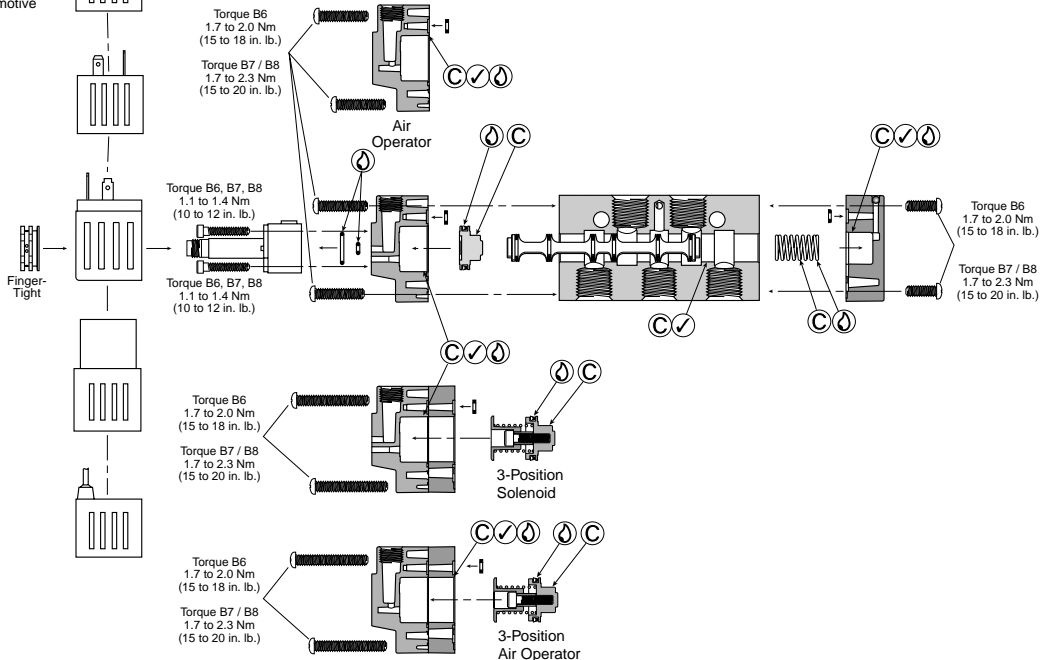
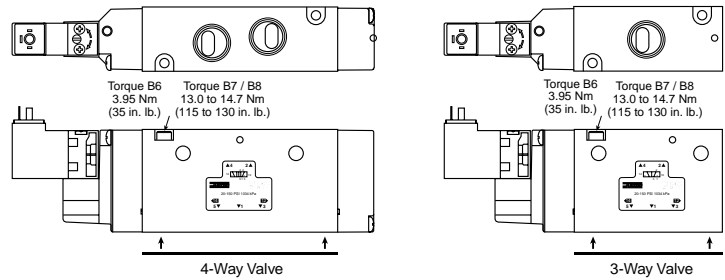
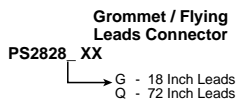
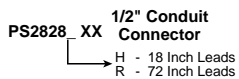
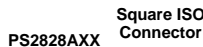
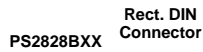
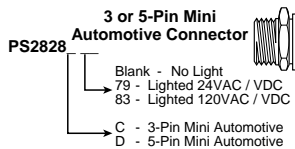



Pneumatic Division
 Richland, Michigan 49083

Assembly Procedure: V-513CP

**B6, B7, B8 Series Valve
 Extruded Manifold**

ISSUED: July, 2001

Supersedes: June, 2001

ECN# P28390, Rev. 3

Application limits, wiring instructions, and instructions for the proper installation of the valves for this manifold are shown in instruction form V-510P, which was shipped with the valve. Service kits and other service instruction sheets are also referenced on this form. Copies of instruction form V-510P are available from your local representative.

! WARNING

Air exhausting from one valve into the exhaust gallery of the manifold may pressurize other valve circuits open to the same gallery. Design the circuit such that there is no hazard or damage consequence from this action.

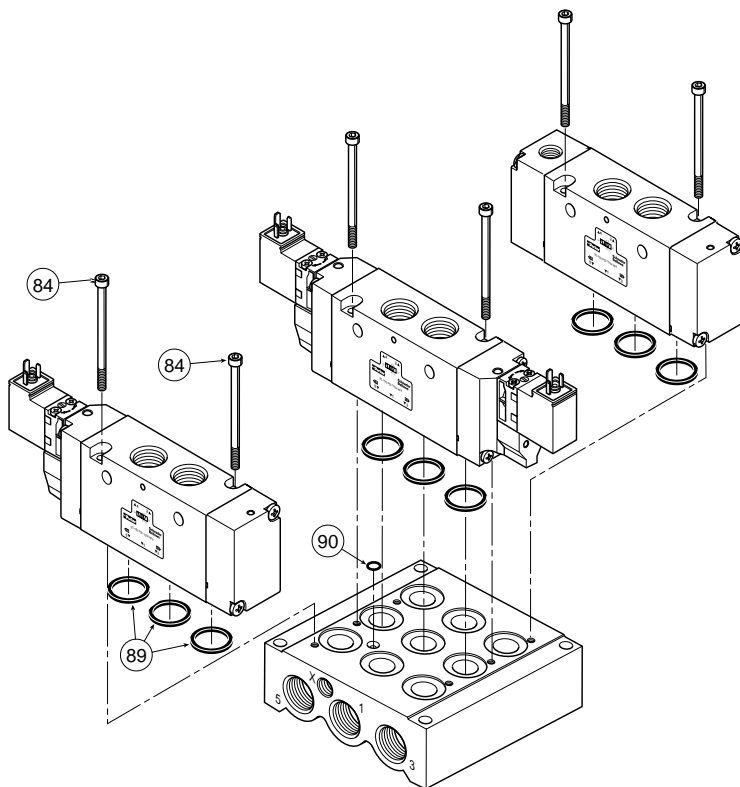

B6 4-Way Manifold
 Shown

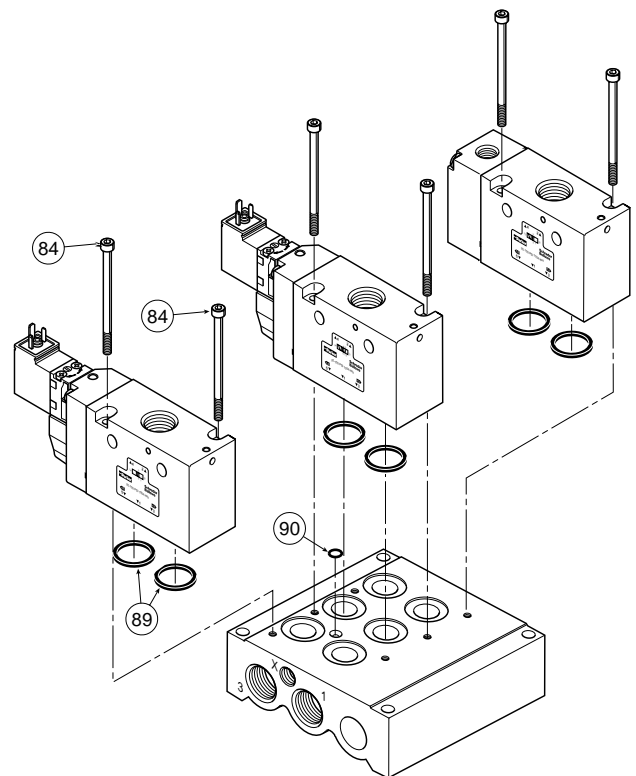

B6 3-Way Manifold
 Shown

Assembly Procedure:

Notes:

1. For 4-Way valves, it is recommended valves be installed so outlet ports #4 are all in line. When externally piloted 4-Way valves are installed on the manifold, Port 4 on the valve must be nearest Port 5 on the manifold. For 3-Way valves, Port 2 on the valve must line up with Port 3 on the manifold.
2. If isolator plugs are being used, they should be installed per the instructions on the reverse side, preferably before installing the valves.

Assembly:

1. Place bar manifold horizontal with o-ring grooves facing up. For B6 3-Way manifolds, install the two o-rings into the two counterbores on top. For all other manifolds, install three o-rings (Item #89) into three counterbores.

For externally piloted valves through the manifold, install the small o-ring provided (Item #90) in the small counterbore on top of the manifold.

2. Place each valve at its corresponding location and fasten with socket head cap screws (Item #84). For B6 valves, tighten screws to 1.7 to 2.3 Nm (15 to 20 in-lb) torque using 3mm hex wrench. For B7 / B8 valves, tighten screws to 13 to 15 Nm (115 to 130 in-lb) torque.
3. Make plumbing and electrical connections.
4. Turn on air pressure and electrical power source. Test for proper functional operation and for internal and external air leakage. If leakage is audible (indicating improper assembly is likely), do not operate - conduct assembly again.

3 & 4-Way Inlet Block / Blanking Plate Kit

B6	B7 / B8	Description
PS2620P	PS2520P	Universal Blanking Plate Kit, NPT
PS2621P	PS2521P	Universal Blanking Plate Kit, BSPP
PS2669P	PS2569P	IEM Blanking Plate Kit, NPT

1. For B6 3-Way valves, install two of the three o-rings provided. For all other valves, install 3 o-rings provided in kit (Item #89), provided with base, into counterbores on top of manifold base.
2. Place flat surface of plate (Item #92) (opposite port countersinks) onto manifold and install two (2) hold down screws (Item #93). For B6 valves, tighten screws to 1.7 to 2.3 Nm (15 to 20 in-lb) torque using 3mm hex wrench. For B7 / B8 valves, tighten screws to 13 to 15 Nm (115 to 130 in-lb) torque.
3. If being used as a blanking plate, install three (3) pipe plugs (Item #94) into ports.
4. For 4-Way valves only: if being used for single pressure intermediate supply, install one pipe plug (Item #94) into two outside ports. Supply connection to common galley #1 is made to center port.
5. For 4-Way valves only: if being used for dual pressure intermediate supply, install one (1) pipe plug (Item #94) into center port. Supply pressures are supplied to the two outside ports. The higher pressure is to be supplied to the port nearest port #2 on other valves in the assembly.
6. For 4-Way valves only: if being used for additional exhaust ports, install one (1) pipe plug (Item #94) into the center port for single pressure systems or two (2) pipe plugs (Item #94) into the two outside ports for dual pressure systems.
7. Turn on air pressure and check for leakage. If leakage is audible (indicating improper assembly is likely), do not operate - conduct assembly again.

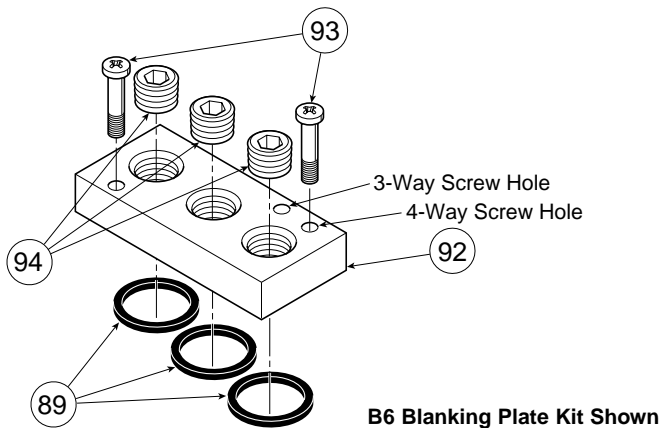

EXTRA COPIES OF THESE INSTRUCTIONS ARE AVAILABLE FOR INCLUSION IN EQUIPMENT / MAINTENANCE INSTRUCTION MANUALS THAT UTILIZE THESE PRODUCTS. CONTACT YOUR LOCAL REPRESENTATIVE.

! WARNING

FAILURE OR IMPROPER SELECTION OR IMPROPER USE OF THE PRODUCTS AND/OR SYSTEMS DESCRIBED HEREIN OR RELATED ITEMS CAN CAUSE DEATH, PERSONAL INJURY AND PROPERTY DAMAGE.

This document and other information from Parker Hannifin Corporation, its subsidiaries and authorized distributors provide product and/or system options for further investigation by users having technical expertise. It is important that you analyze all aspects of your application, including consequences of any failure and review the information concerning the product or system in the current product catalog. Due to the variety of operating conditions and applications for these products or systems, the user, through its own analysis and testing, is solely responsible for making the final selection of the products and systems and assuring that all performance, safety and warning requirements of the application are met.

The products described herein, including without limitation, product features, specifications, designs, availability and pricing, are subject to change by Parker Hannifin Corporation and its subsidiaries at any time without notice.



Pneumatic Division
Richland, Michigan 49083
269-629-5000

PDNSG-1

Pneumatic Division Safety Guide

ISSUED: August 1, 2006

Supersedes: June 1, 2006

Safety Guide For Selecting And Using Pneumatic Division Products And Related Accessories

⚠ WARNING:

FAILURE OR IMPROPER SELECTION OR IMPROPER USE OF PNEUMATIC DIVISION PRODUCTS, ASSEMBLIES OR RELATED ITEMS ("PRODUCTS") CAN CAUSE DEATH, PERSONAL INJURY, AND PROPERTY DAMAGE. POSSIBLE CONSEQUENCES OF FAILURE OR IMPROPER SELECTION OR IMPROPER USE OF THESE PRODUCTS INCLUDE BUT ARE NOT LIMITED TO:

- Unintended or mistimed cycling or motion of machine members or failure to cycle
- Work pieces or component parts being thrown off at high speeds.
- Failure of a device to function properly for example, failure to clamp or unclamp an associated item or device.
- Explosion
- Suddenly moving or falling objects.
- Release of toxic or otherwise injurious liquids or gasses.

Before selecting or using any of these Products, it is important that you read and follow the instructions below.

1. GENERAL INSTRUCTIONS

- 1.1. Scope:** This safety guide is designed to cover general guidelines on the installation, use, and maintenance of Pneumatic Division Valves, FRLs (Filters, Pressure Regulators, and Lubricators), Vacuum products and related accessory components.
- 1.2. Fail-Safe:** Valves, FRLs, Vacuum products and their related components can and do fail without warning for many reasons. Design all systems and equipment in a fail-safe mode, so that failure of associated valves, FRLs or Vacuum products will not endanger persons or property.
- 1.3. Relevant International Standards:** For a good guide to the application of a broad spectrum of pneumatic fluid power devices see: ISO 4414:1998, Pneumatic Fluid Power – General Rules Relating to Systems. See www.iso.org for ordering information.
- 1.4. Distribution:** Provide a copy of this safety guide to each person that is responsible for selection, installation, or use of Valves, FRLs or Vacuum products. Do not select, or use Parker valves, FRLs or vacuum products without thoroughly reading and understanding this safety guide as well as the specific Parker publications for the products considered or selected.
- 1.5. User Responsibility:** Due to the wide variety of operating conditions and applications for valves, FRLs, and vacuum products Parker and its distributors do not represent or warrant that any particular valve, FRL or vacuum product is suitable for any specific end use system. This safety guide does not analyze all technical parameters that must be considered in selecting a product. The user, through its own analysis and testing, is solely responsible for:
 - Making the final selection of the appropriate valve, FRL, Vacuum component, or accessory.
 - Assuring that all user's performance, endurance, maintenance, safety, and warning requirements are met and that the application presents no health or safety hazards.
 - Complying with all existing warning labels and / or providing all appropriate health and safety warnings on the equipment on which the valves, FRLs or Vacuum products are used; and,
 - Assuring compliance with all applicable government and industry standards.
- 1.6. Safety Devices:** Safety devices should not be removed, or defeated.
- 1.7. Warning Labels:** Warning labels should not be removed, painted over or otherwise obscured.
- 1.8. Additional Questions:** Call the appropriate Parker technical service department if you have any questions or require any additional information. See the Parker publication for the product being considered or used, or call 1-800-CPARKER, or go to www.parker.com, for telephone numbers of the appropriate technical service department.

2. PRODUCT SELECTION INSTRUCTIONS

- 2.1. Flow Rate:** The flow rate requirements of a system are frequently the primary consideration when designing any pneumatic system. System components need to be able to provide adequate flow and pressure for the desired application.
- 2.2. Pressure Rating:** Never exceed the rated pressure of a product. Consult product labeling, Pneumatic Division catalogs or the instruction sheets supplied for maximum pressure ratings.
- 2.3. Temperature Rating:** Never exceed the temperature rating of a product. Excessive heat can shorten the life expectancy of a product and result in complete product failure.
- 2.4. Environment:** Many environmental conditions can affect the integrity and suitability of a product for a given application. Pneumatic Division products are designed for use in general purpose industrial applications. If these products are to be used in unusual circumstances such as direct sunlight and/or corrosive or caustic environments, such use can shorten the useful life and lead to premature failure of a product.
- 2.5. Lubrication and Compressor Carryover:** Some modern synthetic oils can and will attack nitrile seals. If there is any possibility of synthetic oils or greases migrating into the pneumatic components check for compatibility with the seal materials used. Consult the factory or product literature for materials of construction.
- 2.6. Polycarbonate Bowls and Sight Glasses:** To avoid potential polycarbonate bowl failures:
 - Do not locate polycarbonate bowls or sight glasses in areas where they could be subject to direct sunlight, impact blow, or temperatures outside of the rated range.
 - Do not expose or clean polycarbonate bowls with detergents, chlorinated hydro-carbons, ketones, esters or certain alcohols.
 - Do not use polycarbonate bowls or sight glasses in air systems where compressors are lubricated with fire resistant fluids such as phosphate ester and di-ester lubricants.

Pneumatic Division Safety Guide

2.7. Chemical Compatibility: For more information on plastic component chemical compatibility see Pneumatic Division technical bulletins Tec-3, Tec-4, and Tec-5

- 2.8. Product Rupture:** Product rupture can cause death, serious personal injury, and property damage.
- Do not connect pressure regulators or other Pneumatic Division products to bottled gas cylinders.
 - Do not exceed the maximum primary pressure rating of any pressure regulator or any system component.
 - Consult product labeling or product literature for pressure rating limitations.

3. PRODUCT ASSEMBLY AND INSTALLATION INSTRUCTIONS

- 3.1. Component Inspection:** Prior to assembly or installation a careful examination of the valves, FRLs or vacuum products must be performed. All components must be checked for correct style, size, and catalog number. DO NOT use any component that displays any signs of nonconformance.
- 3.2. Installation Instructions:** Parker published Installation Instructions must be followed for installation of Parker valves, FRLs and vacuum components. These instructions are provided with every Parker valve or FRL sold, or by calling 1-800-CPARKER, or at www.parker.com.
- 3.3. Air Supply:** The air supply or control medium supplied to Valves, FRLs and Vacuum components must be moisture-free if ambient temperature can drop below freezing

4. VALVE AND FRL MAINTENANCE AND REPLACEMENT INSTRUCTIONS

- 4.1. Maintenance:** Even with proper selection and installation, valve, FRL and vacuum products service life may be significantly reduced without a continuing maintenance program. The severity of the application, risk potential from a component failure, and experience with any known failures in the application or in similar applications should determine the frequency of inspections and the servicing or replacement of Pneumatic Division products so that products are replaced before any failure occurs. A maintenance program must be established and followed by the user and, at minimum, must include instructions 4.2 through 4.10.
- 4.2. Installation and Service Instructions:** Before attempting to service or replace any worn or damaged parts consult the appropriate Service Bulletin for the valve or FRL in question for the appropriate practices to service the unit in question. These Service and Installation Instructions are provided with every Parker valve and FRL sold, or are available by calling 1-800-CPARKER, or by accessing the Parker web site at www.parker.com.
- 4.3. Lockout / Tagout Procedures:** Be sure to follow all required lockout and tagout procedures when servicing equipment. For more information see: OSHA Standard – 29 CFR, Part 1910.147, Appendix A, The Control of Hazardous Energy – (Lockout / Tagout)
- 4.4. Visual Inspection:** Any of the following conditions requires immediate system shut down and replacement of worn or damaged components:
- Air leakage: Look and listen to see if there are any signs of visual damage to any of the components in the system. Leakage is an indication of worn or damaged components.
 - Damaged or degraded components: Look to see if there are any visible signs of wear or component degradation.
 - Kinked, crushed, or damaged hoses. Kinked hoses can result in restricted air flow and lead to unpredictable system behavior.
 - Any observed improper system or component function: Immediately shut down the system and correct malfunction.
 - Excessive dirt build-up: Dirt and clutter can mask potentially hazardous situations.

Caution: Leak detection solutions should be rinsed off after use.

4.5. Routine Maintenance Issues:

- Remove excessive dirt, grime and clutter from work areas.
- Make sure all required guards and shields are in place.

4.6. Functional Test: Before initiating automatic operation, operate the system manually to make sure all required functions operate properly and safely.

4.7. Service or Replacement Intervals: It is the user's responsibility to establish appropriate service intervals. Valves, FRLs and vacuum products contain components that age, harden, wear, and otherwise deteriorate over time. Environmental conditions can significantly accelerate this process. Valves, FRLs and vacuum components need to be serviced or replaced on routine intervals. Service intervals need to be established based on:

- Previous performance experiences.
- Government and / or industrial standards.
- When failures could result in unacceptable down time, equipment damage or personal injury risk.

4.8. Servicing or Replacing of any Worn or Damaged Parts: To avoid unpredictable system behavior that can cause death, personal injury and property damage:

- Follow all government, state and local safety and servicing practices prior to service including but not limited to all OSHA Lockout Tagout procedures (OSHA Standard – 29 CFR, Part 1910.147, Appendix A, The Control of Hazardous Energy – Lockout / Tagout).
- Disconnect electrical supply (when necessary) before installation, servicing, or conversion.
- Disconnect air supply and depressurize all air lines connected to system and Pneumatic Division products before installation, service, or conversion.
- Installation, servicing, and / or conversion of these products must be performed by knowledgeable personnel who understand how pneumatic products are to be applied.
- After installation, servicing, or conversions air and electrical supplies (when necessary) should be connected and the product tested for proper function and leakage. If audible leakage is present, or if the product does not operate properly, do not put product or system into use.
- Warnings and specifications on the product should not be covered or painted over. If masking is not possible, contact your local representative for replacement labels.

4.9. Putting Serviced System Back into Operation: Follow the guidelines above and all relevant Installation and Maintenance Instructions supplied with the valve FRL or vacuum component to insure proper function of the system.