



POWDER, DUST & BULK MATERIALS

MEASUREMENT *and* CONTROL CATALOG



- *Dust Collection*
- *Pneumatic Conveying*
- *Material Handling, Processing and Storage*

Introduction

Dwyer Instruments has and continues to be a leading manufacturer of instrumentation for controlling and monitoring powder, dust, and powder materials. In this catalog you will find our most popular products for material handling and processing applications, many of which are designed specifically for use in dust collectors and pneumatic conveying systems.

Dwyer started in this industry with our very popular differential pressure gages and switch gages. The Magnehelic® gage and Photohelic® gage remain the workhorses of the industry and continue to exceed customer expectations due to their simple operation and robust design. New in this catalog you will find a digital Photohelic® gage, the series DH, and a digital Magnehelic® gage, the series DM2000. We have continually expanded our product offering for this industry to help serve our customers. With input from you we keep designing products that meet your specific application needs.

Featured in this catalog you will find our very successful DCT Series of timer controllers that far exceed the capabilities of other products on the market. The DCT Series timer controllers are easy to use, are cost effective, and offer a feature set tailored to your needs. Expanding our offering for pulse jet clean dust collection we have added, new this year, a complete line of pulse valves, solenoid valves, and bulk head connectors.

Our Proximity Controls Division has been manufacturing level controls for this industry since 1965. We have added both paddle and capacitive technologies to our Proximity offering in recent years. The new CLS2 capacitive level switch offers state of the art technology at an industry leading price making it ideal for use in pneumatic conveying systems.

We have always felt that the best does not have to cost you the most, and encourage you, the customer, to check our value and what we feel to be the most competitively priced products on the market.

Sincerely,
Dwyer Instruments Team



Locations Worldwide:



Dwyer Instruments, Incorporated, has presence in over 50 countries. Please contact us for your nearest representative.

Corporate Headquarters

Dwyer Instruments, Inc.
102 Indiana Highway 212
P.O. Box 373
Michigan City, IN. 46361 U.S.A.
Telephone: 219/879-8000
Fax: 219/872-9057

United Kingdom

Dwyer Instruments Limited
Unit 16, The Wye Estate, London Road
High Wycombe, Bucks HP11 1LH-U.K.
Telephone: (+44) (0)1494 461707
Fax: (+44) (0)1494 465102

Australia

Dwyer Instruments, Pty. Ltd.
Unit 1, 11 Waverley Drive
Unanderra, NSW 2526 Australia
Telephone: 61 2 4272 2055
Fax: 61 2 4272 4055

Houston Office

Telephone: 281/446-1146
Fax: 281/446-0696

How to Order:

To place orders & for Customer Service and Technical Support

PHONE

800/872-9141
219/879-8000

FAX

219/872-9057

ONLINE

www.dwyer-inst.com

View your orders using our new online feature, **CHECK ORDER STATUS**. Order quantity, model number, schedule/shipment and tracking information is available. View listings of open and closed orders for the past 30 working days.

For Product Information:

INTERNET

www.dwyer-inst.com
www.dust-controls.com
www.love-controls.com
www.mercoid.com
www.proximitycontrols.com

EMAIL

General Info: info@dwyer-inst.com
Literature: lit@dwyer-inst.com
Technical: tech@dwyer-inst.com
Quotes: quotes@dwyer-inst.com

INTERNATIONAL

United Kingdom: www.dwyer-inst.co.uk
Australia: www.dwyer-inst.com.au

DWYER IS SERVICE



Customer Service

Customer Service

Easy, friendly and fast

Dwyer wants to help you get your job done quickly and easily. Courteous and professional customer service representatives are available via phone or email to process and provide assistance with your order. Dwyer prides itself on being industry leaders in response time.



Technical Support

Technical Support

We provide you with the solutions you need

Dwyer is here to help you with technical and application support. All of our technical staff are degreed engineers trained to be product and industry experts. We will help you get the right product for your application and support the product once you already have it.



Prompt Shipments

Product Delivery

Prompt shipments

Dwyer is committed to get you your order quickly. We maintain inventory for most products at our Michigan City, IN USA location. Our dedicated shipping staff packs and ships your order promptly within 24 hours on most in-stock items.

Website

*It's all here for you,
anytime you need it*

We deliver the convenience you want – order information, product information and order placement all on the web. Available at anytime.



Order Information

- Model numbers and pricing are easy to find
- Normal inventory availability displayed

Product Information

- Catalog pages in PDF format – view, print or save to your computer
- Instruction manuals in PDF format – view, print or save to your computer
- Product dimensions viewable through your web browser
- Product specifications viewable through your web browser
- Agency approval certificates – CE, FM, UL, CSA and ATEX
- Application guides
- Frequently asked questions

Order Online

- Online shopping cart
- Email confirmation of order placement and shipment



www.dwyer-inst.com

Table of Contents

Dust Collection Application	6-7
Pneumatic Conveying Application	8-9

TIMER-CONTROLLERS

Series DCT1000 Dust Collector Timer Controller	10-11
Series DCT1000DC Dust Collector Timer Controller	12
Series DCT500A Low Cost Timer Controller	13
Series DCT500ADC Low Cost Timer Controller	13
Series DCT600 Timer Controller	14
Complete Control Packages	15
Photohelic® Pressure Switch/Gage On-Demand Cleaning Controller ..	16

PRESSURE GAGES

Series 2000 Magnehelic® Differential Pressure Gage	17
Series 2-5000 Minihelic®II Differential Pressure Gage	18
Series SGX & SGF 2.5" Stainless Steel Low Pressure Gage	19
Series SGI 4" Stainless Steel Safety Gage	20
Series SGD & SGT 2.5" Stainless Steel Industrial Pressure Gages	21
Series SGS 4" Stainless Steel Industrial Pressure Gage	22
Series 763 & 764 Field-Fillable & Glycerin-Filled Process Gages	23
Series TPG Temperature & Pressure Gage	24
Series DPG-100 Digital Pressure Gage	25
Series DPGA & DPGW Digital Pressure Gage	26
Series DPG-200 Digital Pressure Gage	27
Series DSGT Digital Indicating Transmitter	28

PRESSURE SWITCHES

Series A3000 Photohelic® Pressure Switch/Gage	29
Series 3000MR/3000MRS Photohelic® Switch/Gage	30
Series MP Mini-Photohelic® Differential Pressure Switch/Gage	31
Series DH3 Digihelic® Differential Pressure Controller	32
Series DHII Digihelic® II Differential Pressure Controller	33
Series DH Digihelic® Differential Pressure Controller	34-35
Series 1900 Compact Low Differential Pressure Switch	36
Series 1950 Explosion-Proof Differential Pressure Switch	37
Series DA/DS Vacuum and Pressure Switches	38

PRESSURE TRANSMITTERS

Series 608 Differential Pressure Transmitter	39
Series MS Magnesense® Differential Pressure Transmitter	40-41
Series 616OT One-Touch™ Differential Pressure Transmitter	42
Series 616C Differential Pressure Transmitter	42
Series 616W Differential Pressure Transmitter	43
Series DM-2000 Differential Pressure Transmitter	44
Series 605 Magnehelic® Differential Pressure Indicating Transmitter	45
Series 626/628 Industrial Pressure Transmitter	46-47
Series IS626 Intrinsically Safe Pressure Transmitter	48
Series FDT Flush Diaphragm Transmitter	49

LEVEL/VIBRATORS

Series PLS Paddle Level Switch	50-51
Series CLS2 Capacitive Level Switch	52-53
Explosion-Proof Ultra Mag™ Level Switches	54-56
Series TFLS Tuning Fork Level Switch	57
Series LTS Tilt Switch Probe	58
Series LTC Tilt Switch Control Unit	58

Model DBLM Mini-Bin Dry Bulk Level Monitor	59
Series PS Proximity Sensors	59
Model CLS1 Capacitance Level Switch	60
Series CRF2 Capacitive Level Transmitter	61
Series BPV Pneumatic Ball Vibrator	62
Series PRV Pneumatic Roller Vibrator	63
Series PTV Pneumatic Turbine Vibrator	64
Series IPV Air Hammer	65
Series APV Piston Vibrator	66

PARTICULATE/AIR VELOCITY

Series PMS Particulate Sensor	67
Series DPM Particulate Monitor & Control	68
Series PMT Particulate Transmitter	69
Series 471 Digital Thermo-Anemometer	70
Air Velocity Kits	71
Series 160 Stainless Steel Pitot Tubes	72
Series 641B Air Velocity Transmitter	73
Series 641RM Air Velocity Transmitter with Cable	74
Series 641 Air Velocity Transmitter	75

SPEED SENSORS

Series DSS Direct-Contact Speed Switch	76
Series NSS Non-Contact Speed Switch	77
Series NSS Non-Contact Speed Switch Accessories	78

TEMPERATURE/POWER

Series 651 Temperature Transmitter	79
Series 659 Push-Button Temperature Transmitter	79
Series RTD Resistance Temperature Detector	80
Series BT Bimetal Thermometers	80
Series CS Current Switches	81
Series UPA-130 Universal Power Alert	81

VALVES

Diaphragm Valves for Reverse Jet Pulse Dust Collection	82
Series DCV/RDCV Diaphragm Valves	83-85
Series RSV Pilot Solenoid Valve	86
Muffler Accessory	86
Series SVE Solenoid Valve Enclosure	87
Dust Collector Timer and Valve Package	88
Series BHC Bulk Head Connector	89
Series DCD Repair Kit	89
Series BV2MB Two-Piece Hand Lever Brass Ball Valve	90
Series DV Timed Automatic Drain Valve	90
Series ABV Automated Two-Piece Brass Ball Valves	91
Series CVA Compact Valve and Actuator	92
Series BFV Butterfly Valves	93
Series ABFV Automated Butterfly Valve	94-96
Series QV Quick-View® Valve Position Indicator/Switch	97

ACCESSORIES

Filters, Regulators and Lubricators	98-101
Series A-1000 Stainless Steel Fitting Line	102-106
Series A-2000 Stainless Steel Fittings	107-108

Index by Product	109
Index by Category	110
Level Products Bulk Density Table	111
Discount Schedule and Conditions of Sale	112

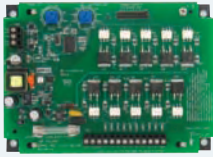

Series DCT600
Timer Controller
page 14



Series BPV, PRV & PTV
Pneumatic Vibrators
pages 62-64



Series TPG
Temperature & Pressure Gage
page 24



Series IPV
Air Hammer
page 65



Series DH3
Digihelic® Differential
Pressure Controller
page 32



Series APV
Piston Vibrator
page 66



Series 6160T
One-Touch™ Differential
Pressure Transmitter
page 42



Series PMS
Particulate Sensor
page 67



Series IS626
Intrinsic Safe Pressure
Transmitter
page 48



Series DPM
Particulate Monitor
& Control
page 68



Series FDT
Flush Diaphragm Transmitter
page 49



Series PMT
Particulate Transmitter
page 69



Series TFLS
Tuning Fork Level Switch
page 57



Series DSS
Direct-Contact Speed Switch
page 76



Series LTS & LTC
Tilt Switches
page 58

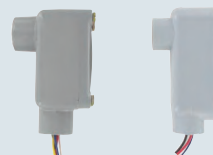

Series NSS
Non-Contact Speed Switch
page 77

Dust Collection Application

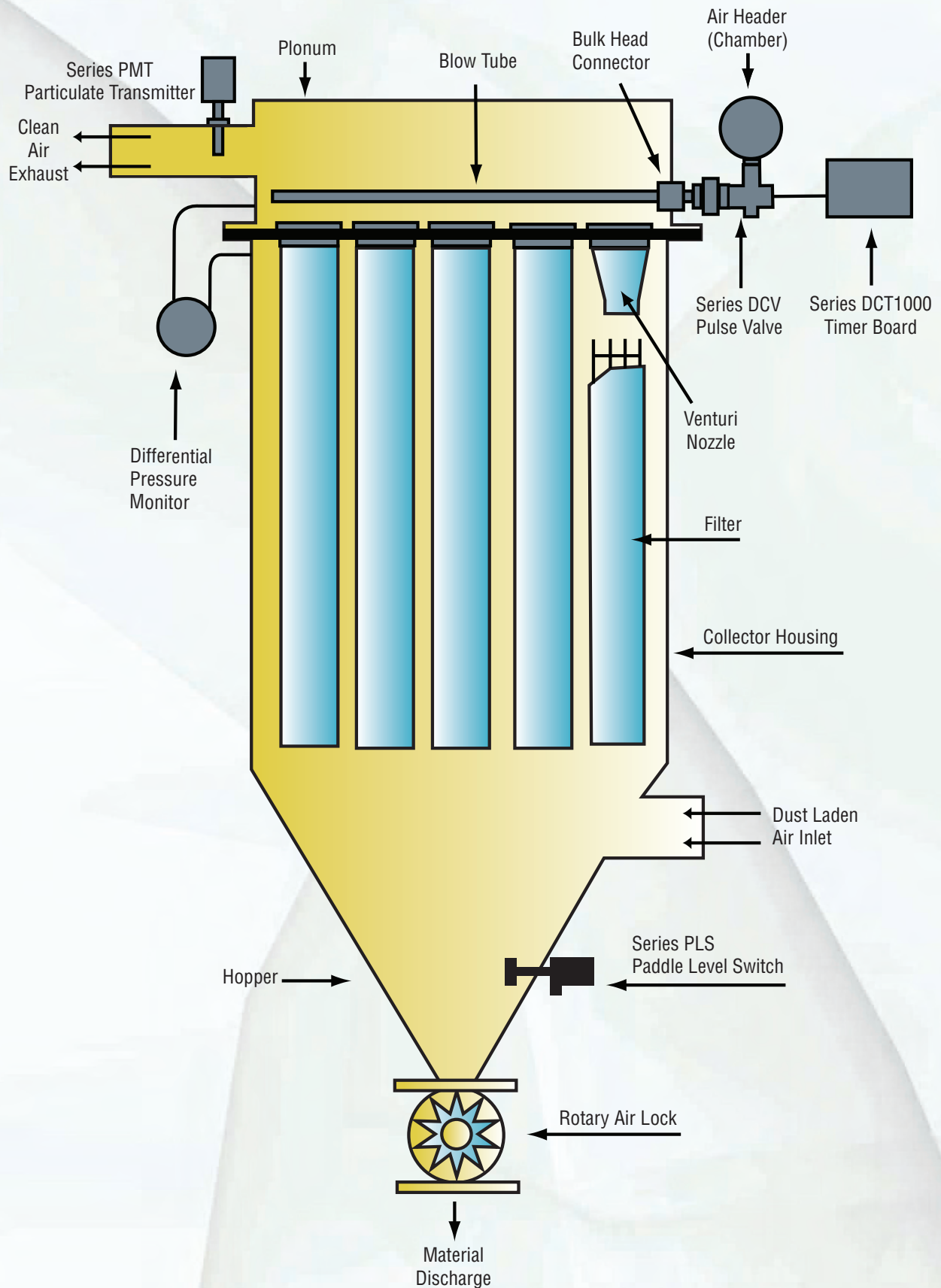

A Total System For Your Dust Collector



Diaphragm Pulse Valves, Series DCV/RDCV: For air pulsing filters.

- ▶ Remote or integral coil
- ▶ NPT or Coupling Connection
- ▶ 3/4" to 3"



Pilot Solenoid Valves, Series RSV: For triggering remote coil diaphragm valves.

- ▶ Individual units or prepackaged into enclosures



Digital Timers/Controllers, Series DCT1000: For controlling pulsing of filters.

- ▶ For on-demand and continuous clean
- ▶ Optional pressure modules to eliminate separate pressure sensor
- ▶ 4 to 255 channel capability



Differential Pressure Gages, Series 2000 Magnehelic® Gage: For monitoring differential air filter pressure drop.



Single Pressure Gages, Series 63000M: For monitoring compressed air line.



Pressure Switch/Gages, Series DH Digihelic® Controller: One unit for both monitoring filter pressure drop and initiating on-demand cleaning.



Pressure Switches, Series 1950: For initiating on-demand cleaning.



Differential Pressure Transmitters, Series 616: For monitoring differential air filter pressure drop.



Single Pressure Transmitters, Series 626, 628: For monitoring compressed air line.



Ball Valves, Series BV2MB: For shutoff of compressed air line.



Level Controls, Series PLS: For monitoring product build up at the bottom of the collector or receiving vessel.

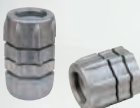

Bulk Head Connectors, Series BHC: For installation of blow tube through the filter.



Particulate Transmitters, Series PMT: For monitoring emissions and detecting broken filters.

Pneumatic Conveying Application

DENSE PHASE PNEUMATIC CONVEYING

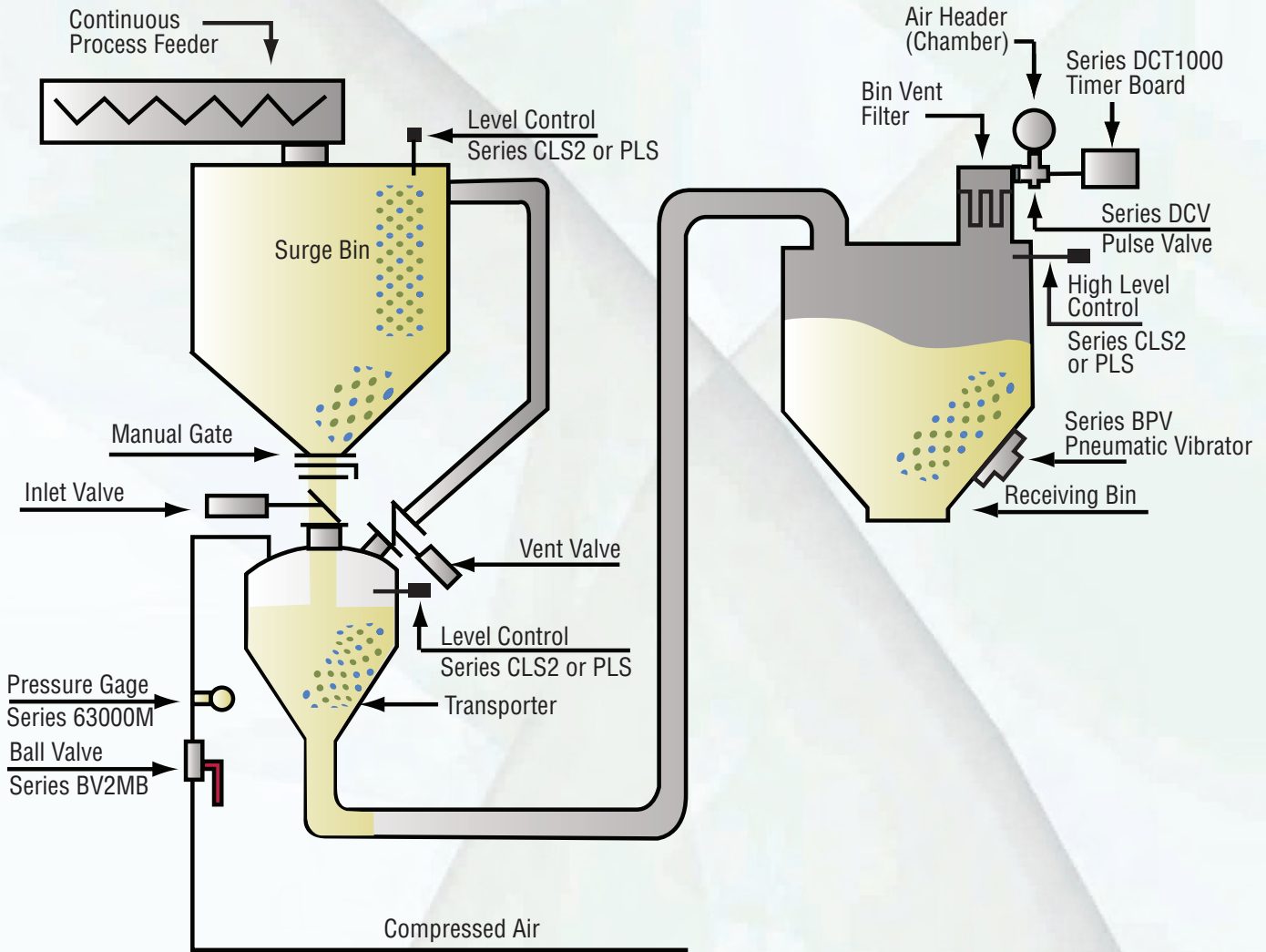

Controls For Pneumatic Conveying

Level Control: For monitoring full and empty status of bins, transporters, receivers and silos.



Series PLS:

- ▶ Rotating paddle level switch
- ▶ Perfect for low pressure dilute phase conveying systems
- ▶ Easy installation



Series CLS2:

- ▶ Capacitive level switch
- ▶ Perfect for high pressure dense phase conveying systems
- ▶ No moving parts to wear, clog, or jam



Ball Valves, Series BV2MB: For shutoff of compressed air line.



Butterfly Valves, Series BFV: For control of flow of product from the surge bin to the transporter.



Pressure Gages, Series 63000M: For monitoring air pressure throughout the system.



Pressure Transmitter, Series 626/628: For monitoring air pressure throughout the system.



Digital Timers/Controllers, Series DCT500: For controlling pulsed cleaning of bin vent filters.



Diaphragm Pulse Valves, Series DCV/RDCV: For air pulsing bin vent filters.

- ▶ Remote or integral coil
- ▶ NPT or coupling connection
- ▶ 3/4" to 3"



Pneumatic Vibrators: For vibrating loose material jams, bridges, or clogs.

A complete, simple controller that reduces both inventory and installation time.

The DCT1000 meets the demands of your dust collection and pneumatic conveying systems.

Terminal Locations for:

- Down Time Cleaning
- Alarm Mode
- Alarm Reset
- Manual Reset
- External Hi-Lo Limit Control (w/o DCP pressure module installed)

Isolated Retransmission Port – Self powered or loop powered 4 to 20 mA.

DCP Plug-in Pressure Module

Universal Power Supply

Accepts line voltages from 85 to 270 VAC/VDC. All low voltage circuitry is isolated for safety.

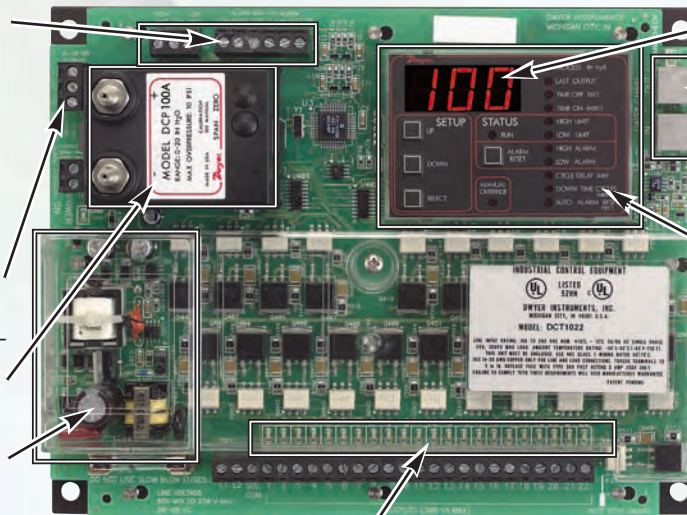

Process Indication – LED Display of Process in inches w.c. (with optional DCP).

Expansion Ports – Allow easy connection between master and expansion boards.

Programmable Control Panel Features:

- Last Output
- Time Off
- Time On
- High/Low Limits
- High/Low Alarms
- Cycle Delay
- Down Time Cleaning
- Auto Alarm Reset

Active Channel Indicators – An LED is provided for each channel and will be illuminated when the solenoid is firing.

The Dwyer® **DCT1000** offers a compact modular design with enhanced features unmatched by industry standards.

Features Include:

- Software menu that is easily accessible and is designed so that you do not need an instruction manual. There are no cumbersome menu keystrokes or passwords required to access the DCT1000.
- High/low limit control capability from an external source such as the Dwyer® Photohelic® Gage.
- Solenoid time/on-time/off settings.
- A universal power supply to meet domestic and overseas requirements.
- Auto/manual control capability so you always have control over the system.
- Downtime cleaning feature that allows for time based pulsing at the end of a plant shift or for completing a batch process.
- Easily select the number of output channels.
- Cycle delay feature that activates a time delay after last solenoid has been actuated.

With the optional **DCP** pressure module that plugs directly into the DCT1000 control board, additional features include:

- Programmable auto/manual reset.
- Programmable high/low limit control settings.
- Isolated 4-20 mA for remote pressure display or to meet data logging requirements.
- SPST alarm relay for high/low operation.
- Continuous process indication.

Channel Expander Features:

Optional channel expanders allow for larger dust collector installations up to 255 channels. Each channel expander has up to 22 triac switches and are similar in appearance to the master controller, with the exception that the channel expanders do not have the on-board display and power supply present.

THE DCT1000. ONE BOARD...ONE SOLUTION...TIMING IS EVERYTHING.

Dust Collector Timer Controller

with Optional DCP Pressure Module



Minimize Your Inventory Requirements:

- Universal power supply accepts 85-270 VAC/VDC at either 50 or 60 Hz. Allows usage in both domestic and overseas installations.
- Modular design allows for use as a continuous cleaning control, or on-demand cleaning control using the plug-in pressure module.
- Mounting holes are standard to other dust collector controllers used in the industry, allowing you to use the DCT1000 for existing installations.
- The DCT1000 is the same size for 6, 10 and 22 channels. One board size means you standardize on one enclosure.

Reduce Need For External Input Devices – What You Need Is All On One Board:

- Alarm relays integral to the DCP plug-in pressure module. Eliminate the additional cost for a pressure switch.
- 4-20 mA process output integral to the DCP plug-in pressure module. No need to purchase an expensive process transmitter.
- Latching relays and jumper wires are eliminated for large installations requiring channel expanders. Each channel expander connected is automatically detected by the DCT1000.

Reduce Field Service Headaches:

- One board means one simple solution to your dust collection control requirements.

SPECIFICATIONS

DCT1000 Timer Controller:

Output Channels: 6, 10, & 22 channels. Expandable to 255 channels using DCT1122 & DCT1110 channel expander boards.

Power Requirements: 85 to 270 VAC, 50 or 60 Hz.

Power Consumption: 5 W.

Solenoid Supply: 3A maximum per channel.

Fuse: 3A @ 250 VAC. Low voltage control circuitry is isolated from the line voltage for system safety.

Temperature Limits: -40 to 140°F (-40 to 60°C).

Storage Temperature Limits: -40 to 176°F (-40 to 80°C).

On Time: 10 msec to 600 msec, 10 msec steps.

On Time Accuracy: +/- 10 msec.

Off Time: 1 second to 255 seconds, 1 second steps.

Off Time Accuracy: ±1% of the value or ±50 msec, whichever is greater.

Weight: 1 lb 3.0 oz (538.6 g).

Agency Approvals: UL, cUL.

DCP Pressure Module:

Pressure Ranges: 10" w.c. or 20" w.c.

Temperature Limits: -40 to 140°F (-40 to 60°C).

Pressure Limit: 10 psi (68.95 kPa).

Pressure Limit (differential): 10 psi (68.95 kPa).

Accuracy: +/- 1.5% F.S. @ 73°F (22.8°C).

Output Signal: 4-20 mA.

Alarm Contacts: 1.5A inductive load, 3A resistive load @ 30 VAC or 40 VDC.

Process Connections: Two barbed connections for use with 1/8" (3.18 mm) or 3/16" (4.76 mm) I.D. tubing.

Weight: 5.5 oz (155.9 g).

Model Number	Description	No. of Channels	D.P. Range
DCT1022	Master Controller	22	
DCT1010	Master Controller	10	
DCT1006	Master Controller	6	
DCT1122	Channel Expander	22	
DCT1110	Channel Expander	10	
DCP200A	Pressure Module		20" w.c.
DCP100A	Pressure Module		10" w.c.

Series
DCT1000DC

Dust Collector Timer Controller

For Low Voltage Applications

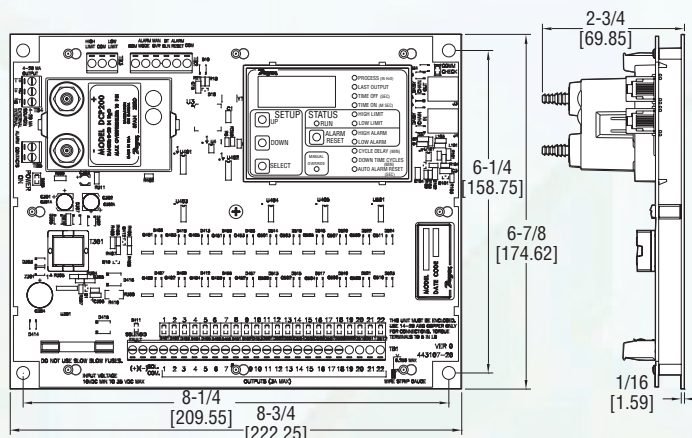
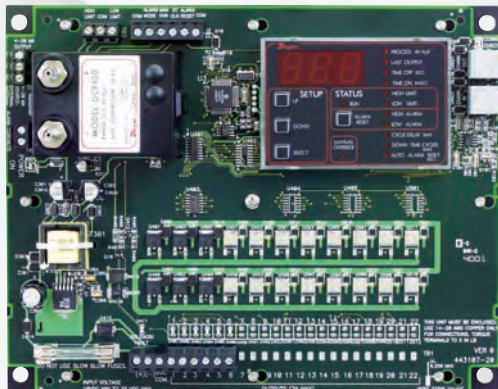

Simplify your on-demand cleaning requirements with the Series DCT1000DC Dust Collector Timer Controller. Relying on one timer board for on demand and continuous cleaning applications, the DCT1000DC eliminates external devices such as pressure switches, relays and timers.

The DCT1000DC accepts 10-30 VDC power. The units modular design allows for use as a continuous cleaning control or on-demand cleaning control using the optional DCP plug-in pressure module. A 4-20 mA process output is integral to the DCP pressure module, eliminating the need to purchase an expensive process transmitter. A solenoid fault light on the DCT1000DC notifies the operator when a solenoid valve fails to activate properly.

The DCT1000DC is the same size for 6, 10 and 22 channels. One board size allows the standardization on one enclosure. For larger installations the DCT1000DC may be expanded by connecting multiple boards in series with the DCA cable.

SPECIFICATIONS

DCT1000DC Timer Controller:

Output Channels: 6, 10, & 22 channels.

Power Requirements: 10 - 30 VDC.

Solenoid Supply: 3A maximum per channel.

Fuse: 3A @ 250 VAC.

Temperature Limits: -40 to 140°F (-40 to 60°C).

Storage Temperature Limits: -40 to 176°F (-40 to 80°C).

On Time: 10 msec to 600 msec, 10 msec steps.

On Time Accuracy: +/- 10 msec.

Off Time: 1 second to 255 seconds, 1 second steps.

Off Time Accuracy: ±1% of the value or ±50 msec, whichever is greater.

Weight: 1 lb 3.0 oz (538.6 g).

DCP Pressure Module:

Pressure Ranges: 10" w.c. or 20" w.c.

Temperature Limits: -40 to 140°F (-40 to 60°C).

Pressure Limit: 10 psi (68.95 kPa).

Pressure Limit (differential): 10 psi (68.95 kPa).

Accuracy: +/- 1.5% F.S. @ 73°F (22.8°C).

Output Signal: 4-20 mA.

Alarm Contacts: 1.5A inductive load, 3A resistive load @ 30 VAC or 40 VDC.

Process Connections: Two barbed connections for use with 1/8" (3.18 mm) or 3/16" (4.76 mm) I.D. tubing.

Weight: 5.5 oz (155.9 g).

Agency Approvals: CE.

OPTIONS

WP – Weatherproof Housing Only

WPP – Weatherproof Housing with Pressure Ports

WPPS – Weatherproof Housing with Pressure Ports, Three Position Rotary Switch Installed

EXPL – Explosion-proof Housing

Multiple Boards stacked in enclosure

ACCESSORIES

DCA, Channel expander cable available in 1 ft., 2 ft., and 4 ft. lengths

Series 1000, Process Indicator

Series 1010, Process Indicator with Alarm



DCT in optional NEMA 4/4X weatherproof enclosure.



DCT in optional Explosion proof Enclosure.



Model DCAC02 Cable Connection: For connecting multiple boards.



DCT expanded with multiple boards.



Model Number	Description	No. of Channels	D.P. Range
DCT1022DC	Master Controller	22	
DCT1010DC	Master Controller	10	
DCT1006DC	Master Controller	6	
DCP200A	Pressure Module		20" w.c.
DCP100A	Pressure Module		10" w.c.

Series
DCT500A

Low Cost Timer Controller

Compact, Easy to Use; 4, 6 or 10 Channels

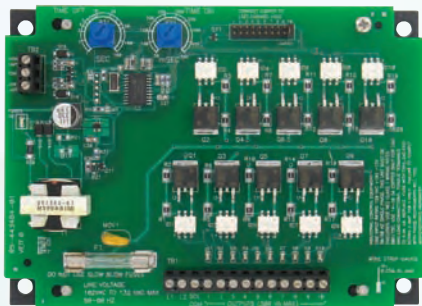

Ideal for pneumatic conveying systems, the Series DCT500A Low Cost Timer Controller is designed to provide continuous or on-demand cleaning for receivers and pulse jet systems. Available in either 4, 6 or 10 channels, each unit is the same size, minimizing enclosure space and reducing overall system installation cost. The DCT500A is simple and easy to use. Time-On and Time-Off settings are selected using two potentiometers. High Limit and Low Limit control inputs are provided for use with on demand systems. The new enhanced board circuitry of the DCT500A synchronizes the on-time pulse to the power line to achieve a pulse stability of ± 1 msec. For added safety, the control circuitry including the control inputs are isolated from the line voltage. To meet your system requirements, an optional weatherproof enclosure is available. For on demand systems, a Dwyer Series A3000 Photohelic® gage or Series 1800 Pressure Switch may be used with the DCT500A.

Model Number	Description	No. of Channels
DCT504A	Timer Controller	4
DCT506A	Timer Controller	6
DCT510A	Timer Controller	10

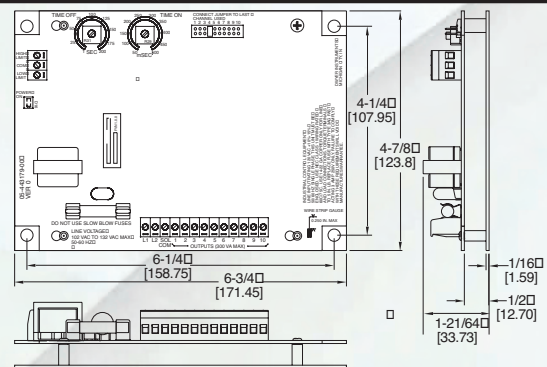

SPECIFICATIONS
Output Channels: 4, 6, & 10 channels.
Power Requirements: 102 to 132 VAC 50 or 60 Hz.
Power Consumption: 2.5 W.
Solenoid Supply: 3A max. per channel.
Fuse: Type 3 AG, 3 A @ 250 VAC.
Temperature Limits: -40 to 176°F (-40 to 80°C).
Storage Temperature Limits: -40 to 176°F (-40 to 80°C).
On Time: 50 msec to 500 msec.
On Time Accuracy: ± 10 msec.
On Time Stability: ± 1 ms.
Off Time: 1 second to 180 seconds.
Off Time Accuracy: $\pm 5\%$ of setting.
Weight: 9 oz (255 g).

OPTIONS
WP – Weatherproof Housing Only
L – Mounting Bracket for Field Retrofits:
 8-1/4 (209.55) x 6-1/4 (158.75)

Series DCT500ADC Low Cost Timer Controller

For Low Voltage Applications

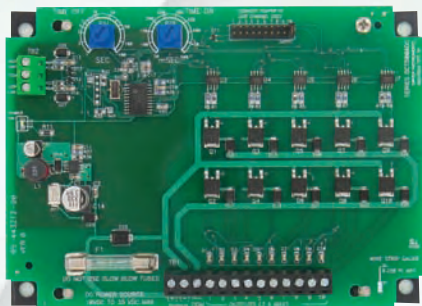

Ideal for pneumatic conveying systems, the Series DCT500ADC Low Cost Timer Controller is designed to provide continuous or on-demand cleaning for 10-35 volt powered receivers and pulse jet systems. Available in either 4, 6 or 10 channels, each unit is the same size, minimizing enclosure space and reducing overall system installation cost. The DCT500ADC is simple and easy to use. Time-On and Time-Off settings are selected using two potentiometers. High Limit and Low Limit control inputs are provided for use with on demand systems. For added safety, the control circuitry including the control inputs are isolated from the line voltage. To meet your system requirements, an optional weatherproof enclosure is available. For on demand systems, a Dwyer Series A3000 Photohelic® gage or Series 1800 Pressure Switch may be used with the DCT500ADC.

Model Number	Description	No. of Channels
DCT504ADC	Timer Controller	4
DCT506ADC	Timer Controller	6
DCT510ADC	Timer Controller	10

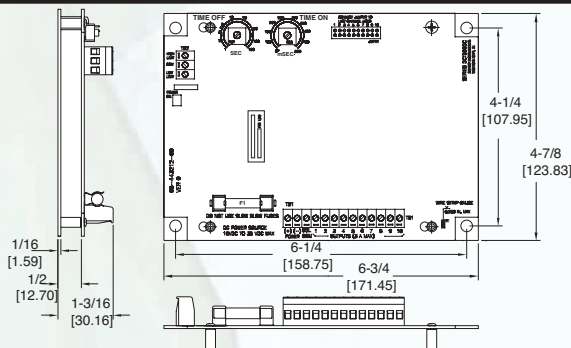

SPECIFICATIONS
Output Channels: 4, 6, & 10 channels.
Power Requirements: 10 to 35 VDC.
Power Consumption: 0.6 W.
Solenoid Supply: 3A max. per channel.
Fuse: Type 3 AG, 3 A @ 250 VAC.
Temperature Limits: -40 to 176°F (-40 to 80°C).
Storage Temperature Limits: -40 to 176°F (-40 to 80°C).
On Time: 50 msec to 500 msec.
On Time Accuracy: ± 10 msec.
On Time Stability: $\leq \pm 1$ ms
Off Time: 1 second to 180 seconds.
Off Time Accuracy: $\pm 5\%$ of setting.
Weight: 9 oz (255 g).

OPTIONS
WP – Weatherproof Housing Only
L – Mounting Bracket for Field Retrofits:
 8-1/4 (209.55) x 6-1/4 (158.75)

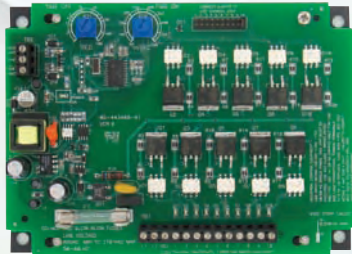

4 thru 10 channel boards

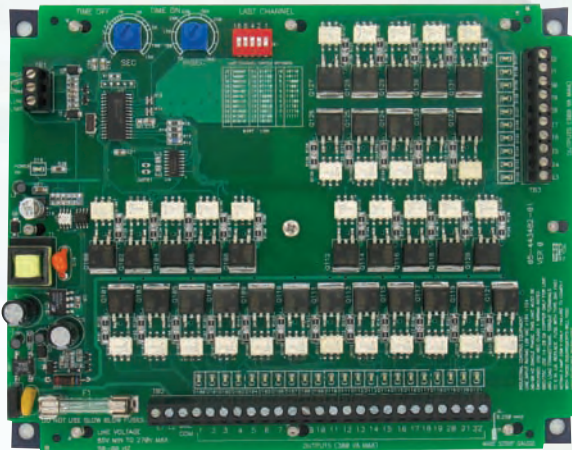

22 and 32 channel board

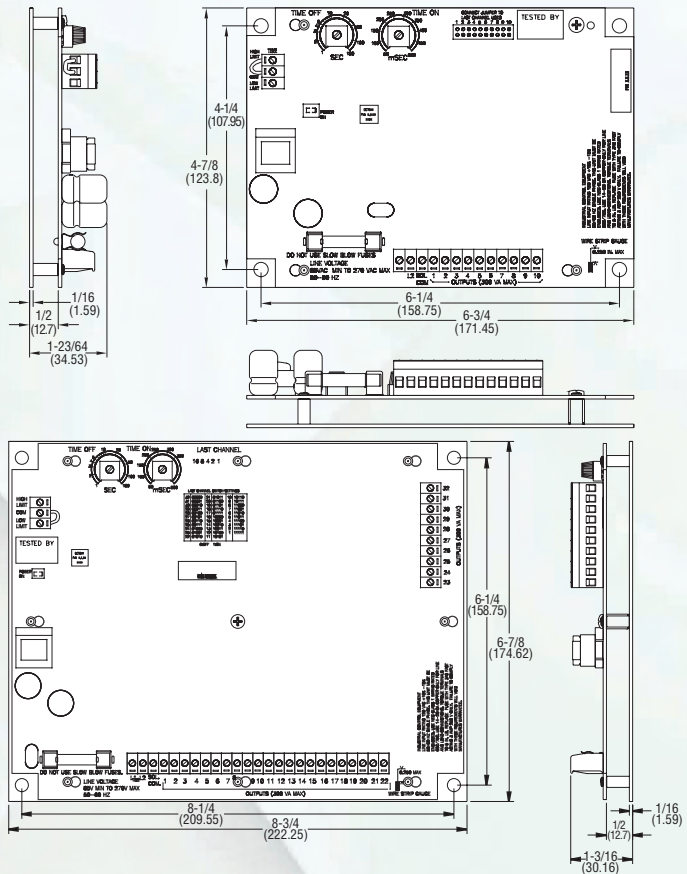

The Series DCT600 Timer Controller is a timing system for pulse-jet type dust collectors or pneumatic conveying systems in either continuous or on-demand cleaning applications. It provides either 4, 6, 10, 22 or 32 channels. The DCT600 was designed for ease of installation in your dust collector system. For installations requiring fewer channels than available on the board, a shorting plug (DCT604 & DCT610) or dip switches (DCT622 & DCT632) allows selection of the last used channel. Time-on and time-off settings are selected using two potentiometers. High-limit and low-limit control inputs are provided for use with on-demand systems. Units can also work in continuous clean mode. The new enhanced board circuitry of the DCT600 synchronizes the on-time pulse to the power line to achieve a pulse stability of ± 1 msec. For safety, the control circuitry including the control inputs and the last channel jumper is isolated from the power line.

SPECIFICATIONS

- Output Channels:** 4, 6, 10, 22 and 32 channels available.
- Power Requirements:** 85 to 270 VAC.
- Power Consumption:** 1.2 W.
- Solenoid Supply:** 300 VA.
- Fuse:** Type 3 AG, 3 A @ 250 VAC.
- Temperature Limits:** -40 to 176°F (-40 to 80°C).
- Storage Temperature Limits:** -40 to 176°F (-40 to 80°C).
- On Time:** 50 msec to 500 msec.
- On Time Accuracy:** $\pm 5\%$ of setting.
- On Time Stability:** ± 1 msec.
- Off Time:** 1 second to 180 seconds.
- Off Time Accuracy:** 5% of setting.
- Weight:** 9 oz (255 g).
- Agency Approvals:** UL, cUL.

OPTIONS

- WP** – Weatherproof Housing (4 thru 10 channel only)
- L** – Mounting Bracket for Field Retrofits (4, 6 or 10 channel boards only): 8-1/4" x 6-1/4" (209.55 mm x 158.75 mm)
- Note:** L mounting bracket available with 4, 6 or 10 channel models only.

Model Number	Description	No. of Channels
DCT604	Timer Controller	4
DCT606	Timer Controller	6
DCT610	Timer Controller	10
DCT622	Timer Controller	22
DCT632	Timer Controller	32

Complete Control Packages

for the Series DCT1000 and Series DCT500



DCT1000 - NEMA 4/4X Weatherproof Enclosure

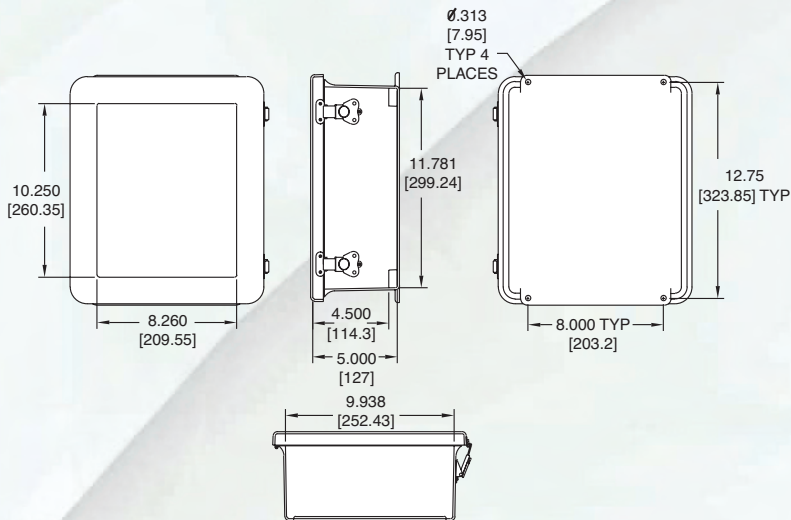

DCT500 - NEMA 4/4X Weatherproof Enclosure

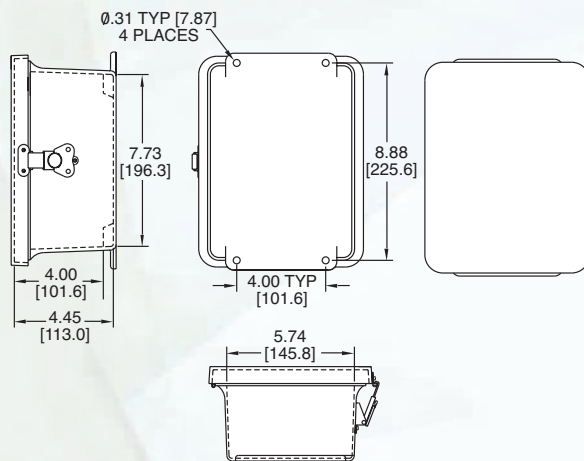

ENCLOSURE PACKAGES

DCT10XX-WP – DCT1000 mounted in Weatherproof Housing

DCT10XX-DCPX00-WPP – Weatherproof Housing with Pressure Ports

DCT10XX-DCPX00-WPPS – Weatherproof Housing with Pressure Ports, Three Position Rotary Switch Installed

DCT5XX-WP – DCT500 Mounted in Weatherproof Enclosure



DCT in optional Explosion-proof Enclosure

DCT10XX-EXPL – DCT1000 mounted in Explosion-proof Housing



44 Channel Package

DCTS3212 – DCT1022 with 22 channel expander and DCP100 pressure module mounted in large weatherproof enclosure. DCP100 connected with tubing to pressure fittings on enclosure. (Various combinations of this package are available, consult factory.)

ACCESSORIES

DCA, Channel expander cable available in 1 ft, 2 ft, and 4 ft lengths

Series 1000, Process Indicator

Series 1010, Process Indicator with Alarm

Photohelic® Pressure Switch/Gages On-Demand Cleaning Controller

Reverse Pulse-Jet Cleaning Initiated by Differential Pressure

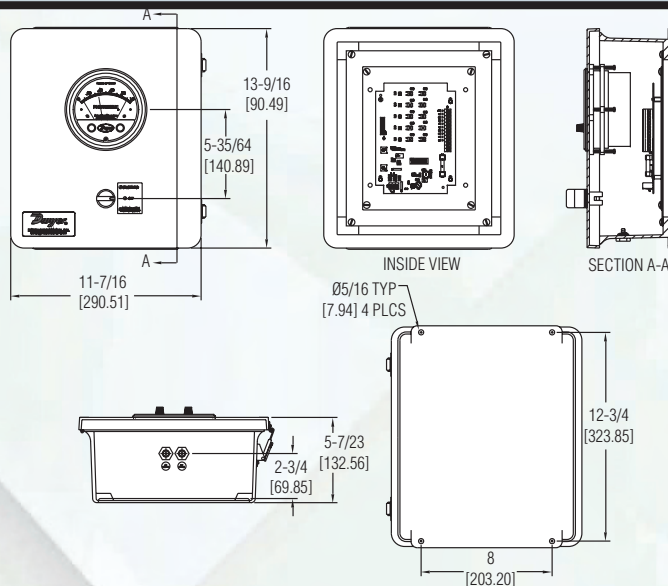

The Photohelic® Pressure Switch/Gages On-Demand Cleaning Controller provides a simple, complete dust collection control all in one enclosure. The Photohelic® controller combined with the DCT500DC Timer Control provides a timed energization of solenoid valves when the differential pressure indicates filter cleaning is necessary. The operator can easily set the cleaning initiation and duration by adjusting the 2 set point knobs on the front face of the Photohelic® controller. Solenoid valve sequencing is also easily set via two potentiometers inside the enclosure on the timer board. A three position switch on the front of the enclosure offers cleaning versatility by allowing the user to select between on-demand or continuous manual cleaning. The Photohelic® controller is pneumatically connected with tubing to fittings on the enclosure. All that is required for start-up is connection of tubing from the process to the external fittings on the enclosure, and wiring the solenoid valves to the timer board.

CONTROLLER FEATURES

- External, manual adjustment of set points with Photohelic® controller adjustment knobs.
- On and off time easily set with 2 potentiometers located on the DCT500DC timer board.
- 3 position switch for selecting between On-Demand Cleaning or continuous manual cleaning.
- Photohelic® controller pre-connected with tubing to pressure fittings on body of enclosure.

MODEL NUMBER	RANGE*
DCTE504ADC-3010MR	10" w.c.
DCTE506ADC-3010MR	10" w.c.
DCTE510ADC-3010MR	10" w.c.

* For other ranges and engineering units contact factory.
 Note: 120 VAC powered timer board also available.

DCT500DC SPECIFICATIONS

- Output Channels:** 4, 6, & 10 channels.
- Power Requirements:** 10 to 35 VDC, 0.6 watt max. no load power. 120 Volt powered timer board also available.
- Solenoid Supply:** 3A max. per channel.
- Fuse:** Type 3 AG, 3A @ 250 VAC.
- Temperature Limits:** -40 to 176°F (-40 to 80°C).
- Storage Temperature Limits:** -40 to 176°F (-40 to 80°C).
- On Time:** 50 msec to 500 msec.
- On Time Accuracy:** ±5% of setting.
- Off Time:** 1 second to 200 seconds.
- Off Time Accuracy:** ±5% of setting.
- Weight:** 9 oz (255 g).

PHOTOHELIC® SPECIFICATIONS GAGE SPECIFICATIONS

- Service:** Air and non-combustible, compatible gases.
- Wetted Materials:** Consult factory.
- Accuracy:** ±2% of full scale.
- Pressure Limits:** -20" Hg to 25 psig (-0.677 bar to 1.72 bar). MP option; 35 psig (2.41 bar), HP option; 80 psig (5.52 bar).
- Temperature Limits:** 20 to 120°F (-6.67 to 48.9°C).
- Process Connections:** 1/8" female NPT (duplicated side and back).
- Size:** 4" (101.6 mm) dial face, 5" (127 mm) O.D. x 3-1/8" (79.38 mm).
- Weight:** 1.8 lb (816 g).

SWITCH SPECIFICATIONS 3000MR

- Switch Type:** Each setpoint has a 1 Form C relay (SPDT).
- Relay Contacts:** (resistive load) 1 Form C rated 1.0A @ 30 VDC, 0.3A @ 110 VDC or 0.5A @ 125 VAC. Gold over clad silver - suitable for dry circuits.
- Electrical Connections:** 18" (46 cm) cable assembly with 8 conductors. Optional lengths to 100' (30.5 m).
- Power Requirements:** 24 VDC, regulated ±10%.
- Mounting Orientation:** Diaphragm in vertical position. Consult factory for other position orientations.
- Set Point Adjustment:** Adjustable knobs on face.

Series
2000

Magnehelic® Differential Pressure Gages

For Monitoring Filtration Systems



Standard Magnehelic® Pressure Gage has a large, easy-to-read 4" dial.

Select the Dwyer® Magnehelic® gage for high accuracy – guaranteed within 2% of full scale – and for the wide choice of 81 models available to suit your needs precisely. Using Dwyer's simple, frictionless Magnehelic® gage movement, it quickly indicates low air or non-corrosive gas pressures – either positive, negative (vacuum) or differential. The design resists shock, vibration and over-pressures. No manometer fluid to evaporate, freeze or cause toxic or leveling problems. It's inexpensive, too.

The Magnehelic® gage is the industry standard to measure fan and blower pressures, filter resistance and air velocity in filtration or pneumatic conveying systems.

NOTE: May be used with Hydrogen where pressures are less than 35 psi.

MOUNTING. A single case size is used for most models of Magnehelic® gages. They can be flush or surface mounted with standard hardware supplied. With the optional A-610 Pipe Mounting Kit they may be conveniently installed on horizontal or vertical 1-1/4" - 2" pipe. Although calibrated for vertical position, many ranges above 1" may be used at any angle by simply re-zeroing. However, for maximum accuracy, they must be calibrated in the same position in which they are used. These characteristics make Magnehelic® gages ideal for both stationary and portable applications. A 4-9/16" hole is required for flush panel mounting. Complete mounting and connection fittings plus instructions are furnished with each instrument.

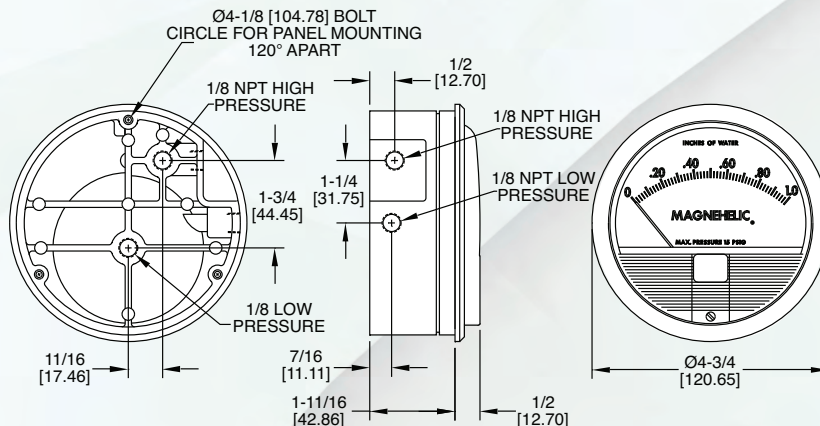

Dimensions, Standard Series 2000 Magnehelic® Pressure Gages. (Slightly different on medium and high pressure models)

SPECIFICATIONS

Service: Air and non-combustible, compatible gases. (Natural Gas option available.)

Wetted Materials: Consult factory.

Housing: Die cast aluminum case and bezel, with acrylic cover. Exterior finish is coated gray to withstand 168 hour salt spray corrosion test.

Accuracy: ±2% of full scale (±3% on -0, -100PA, -125PA, 10MM and ±4% on -00, -60PA, -6MM ranges), throughout range at 70°F (21.1°C).

Pressure Limits: -20" Hg to 15 psig.† (-0.677 bar to 1.034 bar); MP option; 35 psig (2.41 bar), HP option; 80 psig (5.52 bar).

Overpressure: Relief plug opens at approximately 25 psig (1.72 bar), standard gages only.

Temperature Limits: 20 to 140°F* (-6.67 to 60°C).

Size: 4" (101.6 mm) Diameter dial face.

Mounting Orientation: Diaphragm in vertical position. Consult factory for other position orientations.

Process Connections: 1/8" female NPT duplicate high and low pressure taps - one pair side and one pair back.

Weight: 1 lb 2-oz (510 g), MP & HP 2 lb 2 oz (963 g).

Standard Accessories: Two 1/8" NPT plugs for duplicate pressure taps, two 1/8" pipe thread to rubber tubing adapter and three flush mounting adapters with screws. (Mounting and snap ring retainer substituted for 3 adapters in MP & HP gage accessories.)

*Low temperature models available as special option.

†For applications with high cycle rate within gage total pressure rating, next higher rating is recommended. See Medium and High pressure options below.

Model Number	Range Inches of Water	Model Number	Range Zero Center Inches of Water	Model Number	Range, Pascals	Accessories A-299, Surface Mounting Bracket A-300, Flat Flush Mounting Bracket A-310A, 3-Way Vent Valve A-321, Safety Relief Valve A-432, Portable Kit A-605, Air Filter Kit A-610, Pipe Mount Kit
2000-00†	0-.25	2300-0†	.25-0-.25	2000-60PA†	0-60	
2000-0†	0-.50	2301	.5-0-.5	2000-100PA†	0-100	
2001	0-1.0	2302	1-0-1	2000-125PA†	0-125	Scale Overlays — Red, Green, Mirrored or Combination, Specify Locations †These ranges calibrated for vertical scale position. • Accuracy +/-3% •• Accuracy +/-4%
2002	0-2.0	2304	2-0-2	2000-250PA	0-250	
2003	0-3.0	2310	5-0-5	2000-300PA	0-300	
2004	0-4.0	2320	10-0-10	2000-500PA	0-500	
2005	0-5.0	2330	15-0-15	2000-750PA	0-750	
2006	0-6.0			Zero Center Ranges		
2008	0-8.0			2300-250PA	125-0-125	
2010	0-10	Model Number	Range PSI	2300-500PA	250-0-250	
2015	0-15	2201	0-1	Model Number	Range MM of Water	
2020	0-20	2202	0-2	2000-6MM†	0-6	
2025	0-25	2203	0-3	2000-10MM†	0-10	
2030	0-30	2204	0-4	2000-25MM†	0-25	
2040	0-40	2205	0-5	2000-50MM	0-50	
2050	0-50	2210*	0-10	2000-80MM	0-80	
2060	0-60	2215*	0-15	2000-100MM	0-100	
2080	0-80	2220*	0-20	Zero Center Ranges		
2100	0-100	2230**	0-30	2300-20MM†	10-0-10	
2150	0-150					

Minihelic® II Differential Pressure Gages

Compact Air Filter Gage



The Series 2-5000 Minihelic® II low differential pressure gage provides excellent readability in a compact size.

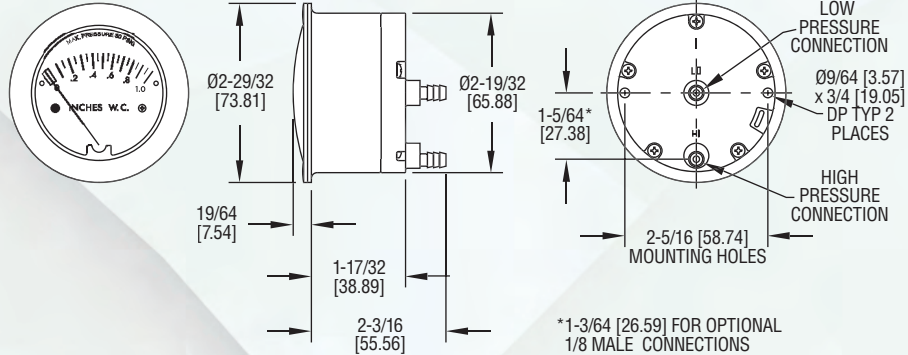

Dimensions, Series 2-5000 Minihelic® II Gage.

Combining clean design, small size and low cost with enough accuracy for all but the most demanding applications our Minihelic® II gage offers the latest in design features for a dial type differential pressure gage. It is our most compact gage but is easy to read and can safely operate at total pressures up to 30 psig. The Minihelic® II is designed for panel mounting in a single 2" diameter hole. Standard pressure connections are barbed fittings for 3/8" I.D. tubing; optional 1/8" male NPT connections are also available. Over-pressure protection is built into the Minihelic II® gage by means of a blow-out membrane molded in conjunction with the diaphragm. Accidental over-ranging up to the rated total pressure will not damage the gage. With removable lens and rear housing, the gage may be easily serviced at minimum cost.

With the housing molded from mineral and glass filled nylon and the lens molded from polycarbonate, the gage will withstand rough use and exposure as well as high total pressure. The 5% accuracy and low cost of the Minihelic® II gage make it well-suited for a wide variety of OEM and user applications. As an air filter gage, the Minihelic® II gage finds many end use applications. The Minihelic® II gage is suitable for many of the same applications as the Magnehelic® gage where the greater accuracy, sensitivity, and higher and lower differential pressure ranges of the Magnehelic® gage are not required.

SPECIFICATIONS

Service: Air and compatible gases.

Wetted Materials: Consult factory.

Housing: Glass filled nylon; polycarbonate lens.

Accuracy: ±5% of full scale at 70°F (21.1°C).

Pressure Limits: 30 psig (2.067 bar) continuous to either pressure connection.

Temperature Limits: 20 to 120°F (-6.67 to 48.9°C).

Size: 2-1/16" (52.39 mm) diameter dial face.

Mounting Orientation: Diaphragm in vertical position. Consult factory for other position orientations.

Process Connections: Barbed, for 3/16" I.D. tubing (standard); 1/8" male NPT (optional).

Weight: 6 oz (170.1 g).

Model Number	Range, Inches of Water	Model Number	Range, PSI	Model Number	Range, MM of Water
2-5000-0	0-0.5	2-5205	0-5	2-5000-25MM	0-25
2-5001	0-1.0	2-5210	0-10	2-5000-50MM	0-50
2-5002	0-2.0	2-5215	0-15	2-5000-100MM	0-100
2-5003	0-3.0	*2-5230	0-30	Model Number	Range, Pascals
2-5005	0-5.0			2-5000-125Pa	0-125
2-5010	0-10			2-5000-250Pa	0-250
2-5020	0-20			2-5000-500Pa	0-500
2-5040	0-40			Model Number	Range, kPa
2-5060	0-60			2-5000-1 kPa	0-1
2-5100	0-100			2-5000-3 kPa	0-3
Accessories		*THIS RANGE EMPLOYS SPIRALLY WOUND BERYLLIUM COPPER BOURDON TUBE POINTER DRIVE MECHANISM. NOTE: CONSULT FACTORY REGARDING AVAILABILITY OF ADDITIONAL RANGES.			
A-434 Portable Kit					
A-497 Surface Mtg. Brkt.					
A-609 Air Filter Kit					

For optional 1/8" male NPT connections, add suffix -NPT to model numbers listed above. Example: 2-5001-NPT. No extra charge.

2.5" Stainless Steel Low Pressure Gage

1.6% Full Scale Accuracy, Brass or 316 SS Wetted Parts

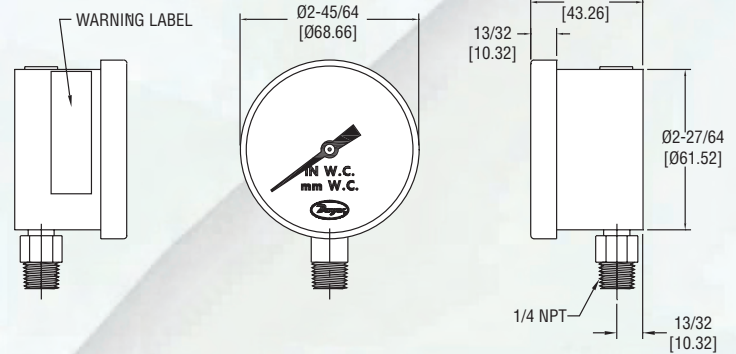

The Series SGX/SGF Gages have dual English/metric scales with $\pm 1.6\%$ full scale accuracy. The Series SGX/SGF gages are designed with 304 SS housing and brass or 316 SS wetted parts. Units can withstand ambient temperatures up to 149°F (65°C) and process temperatures up to 212°F (100°C). Ranges of vacuum, compound and pressures to 235 inches w.c. are available. Included on the dial is a convenient zero adjustment screw which allows the user to easily re-zero the needle.

APPLICATIONS

Pneumatic, Draft Measurement, Filter Monitoring.

SPECIFICATIONS

Service: Compatible gases & liquids.

Wetted Materials: SGX: Brass; SGF: 316/316L SS.

Housing: 304 SS.

Lens: Glass.

Accuracy: $\pm 1.6\%$ full scale.

Pressure Limit: Full scale value.

Temperature Limits:

Ambient: -13 to 149°F (-25 to 65°C);

Process: 212°F max. (100°C max.).

Size: 2.5" (63 mm).

Process Connections: 1/4" male NPT.

Enclosure Rating: NEMA 3 (IP55).

Weight: 4.6 oz (0.13 kg).

Model Number	Ranges	Model Number	Ranges
SGX-D7122N	-10-0 in. w.c. (-250-0 mm)	SGF-D7122N	-10-0 in. w.c. (-250-0 mm)
SGX-D7222N	-15-0 in. w.c. (-400-0 mm)	SGF-D7222N	-15-0 in. w.c. (-400-0 mm)
SGX-D7322N	-25-0 in. w.c. (-600-0 mm)	SGF-D7322N	-25-0 in. w.c. (-600-0 mm)
SGX-D7422N	-40-0 in. w.c. (-1000-0 mm)	SGF-D7422N	-40-0 in. w.c. (-1000-0 mm)
SGX-D7522N	-60-0 in. w.c. (-1600-0 mm)	SGF-D7522N	-60-0 in. w.c. (-1600-0 mm)
SGX-D7622N	-80-0 in. w.c. (-2000-0 mm)	SGF-D7622N	-80-0 in. w.c. (-2000-0 mm)
SGX-D7722N	-100-0 in. w.c. (-2500-0 mm)	SGF-D7722N	-100-0 in. w.c. (-2500-0 mm)
SGX-D7822N	-160-0 in. w.c. (-4000-0 mm)	SGF-D7822N	-160-0 in. w.c. (-4000-0 mm)
SGX-D7922N	-235-0 in. w.c. (-6000-0 mm)	SGF-D7922N	-235-0 in. w.c. (-6000-0 mm)
SGX-D8022N	0-10 in. w.c. (0-250 mm)	SGF-D8022N	0-10 in. w.c. (0-250 mm)
SGX-D8122N	0-15 in. w.c. (0-400 mm)	SGF-D8122N	0-15 in. w.c. (0-400 mm)
SGX-D8222N	0-25 in. w.c. (0-600 mm)	SGF-D8222N	0-25 in. w.c. (0-600 mm)
SGX-D8322N	0-40 in. w.c. (0-1000 mm)	SGF-D8322N	0-40 in. w.c. (0-1000 mm)
SGX-D8422N	0-60 in. w.c. (0-1600 mm)	SGF-D8422N	0-60 in. w.c. (0-1600 mm)
SGX-D8522N	0-80 in. w.c. (0-2500 mm)	SGF-D8622N	0-100 in. w.c. (0-2500 mm)
SGX-D8722N	0-160 in. w.c. (0-4000 mm)	SGF-D8722N	0-160 in. w.c. (0-4000 mm)
SGX-D8822N	0-235 in. w.c. (0-6000 mm)	SGF-D8822N	0-235 in. w.c. (0-6000 mm)
SGX-D8922N	-4-0-6 in. w.c. (-100-0-150 mm)	SGF-D8922N	-4-0-6 in. w.c. (-100-0-150 mm)
SGX-D9022N	-6-0-10 in. w.c. (-150-0-250 mm)	SGF-D9022N	-6-0-10 in. w.c. (-150-0-250 mm)
SGX-D9122N	-8-0-16 in. w.c. (-200-0-400 mm)	SGF-D9122N	-8-0-16 in. w.c. (-200-0-400 mm)
SGX-D9222N	-16-0-24 in. w.c. (-400-0-600 mm)	SGF-D9222N	-16-0-24 in. w.c. (-400-0-600 mm)
SGX-D9322N	-24-0-40 in. w.c. (-600-0-1000 mm)	SGF-D9322N	-24-0-40 in. w.c. (-600-0-1000 mm)
SGX-D9422N	-30-0-50 in. w.c. (-800-0-1200 mm)	SGF-D9422N	-30-0-50 in. w.c. (-800-0-1200 mm)
SGX-D9522N	-40-0-60 in. w.c. (-1000-0-1500 mm)	SGF-D9522N	-40-0-60 in. w.c. (-1000-0-1500 mm)
SGX-D9622N	-60-0-100 in. w.c. (-1500-0-2500 mm)	SGF-D9622N	-60-0-100 in. w.c. (-1500-0-2500 mm)
SGX-D9722N	-80-0-160 in. w.c. (-2000-0-4000 mm)	SGF-D9722N	-80-0-160 in. w.c. (-2000-0-4000 mm)

Series
SGI

4" Stainless Steel Safety Gage

0.5% Full Scale Accuracy, 316L SS Wetted Parts

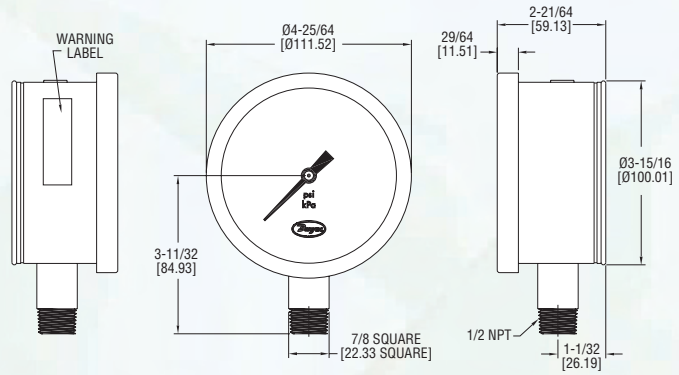

The Series SGI Gages have dual English/metric scales with $\pm 0.5\%$ ASME Grade 2A Accuracy. The solid front design with baffle wall interposed between the sensing element and the window face, plus a pressure relieving back, provides the increased safety required for potentially dangerous applications.

Series SGI gages are designed with 304 SS housings and 316L SS wetted parts for excellent chemical compatibility. Units can withstand ambient temperatures up to 149°F (65°C) and process temperatures up to 518°F (270°C). Series SGI gages may be easily liquid filled in the field without the need for a separate kit. Included is a micrometer adjustable pointer which allows for re-zeroing the gage in the field. A wide selection of ranges are available from full vacuum, compound to 20,000 psi.

SPECIFICATIONS

Service: Compatible gases and liquids.

Wetted Materials: 316L SS.

Housing: 304 SS.

Lens: Shatterproof safety glass.

Accuracy: $\pm 0.5\%$ full scale, ANSI B40.1 Grade 2A.

Pressure Limit: 130% full scale for ranges <10,000 psi, 115% for 10,000 psi and greater.

Temperature Limits:

Ambient: -4 to 149°F (-20 to 65°C);

Process: 518°F max. (270°C max.).

Size: 4" (100 mm).

Process Connections: 1/2" male NPT.

Enclosure Rating: NEMA 3 (IP55).

Weight: 1.3 lb (0.6 kg).

APPLICATIONS

Pneumatics and Compressors.

Model Number	Ranges	Model Number	Ranges
SGI-F0124N	30" Hg-0 (-100-0 kPa)	SGI-F1624N	0-4000 psi (0-28 MPa)
SGI-F0224N	0-15 psi (0-100 kPa)	SGI-F1724N	0-5000 psi (0-34 MPa)
SGI-F0324N	0-30 psi (0-200 kPa)	SGI-F1824N	0-6000 psi (0-40 MPa)
SGI-F0424N	0-60 psi (0-400 kPa)	SGI-F1924N	0-10000 psi (0-70 MPa)
SGI-F0524N	0-100 psi (0-700 kPa)	SGI-F2024N	0-15000 psi (0-100 MPa)
SGI-F0624N	0-150 psi (0-1000 kPa)	SGI-F2124N	30" Hg-0-15 psi (-100-0-100 kPa)
SGI-F0724N	0-200 psi (0-1400 kPa)	SGI-F2224N	30" Hg-0-30 psi (-100-0-200 kPa)
SGI-F0824N	0-300 psi (0-2000 kPa)	SGI-F2324N	30" Hg-0-60 psi (-100-0-400 kPa)
SGI-F0924N	0-400 psi (0-2800 kPa)	SGI-F2424N	30" Hg-0-100 psi (-100-0-700 kPa)
SGI-F1024N	0-500 psi (0-3400 kPa)	SGI-F2524N	30" Hg-0-150 psi (-100-0-1000 kPa)
SGI-F1124N	0-600 psi (0-4000 kPa)	SGI-F2624N	30" Hg-0-200 psi (-100-0-1400 kPa)
SGI-F1224N	0-1000 psi (0-7000 kPa)	SGI-F2724N	30" Hg-0-300 psi (-100-0-2000 kPa)
SGI-F1324N	0-1500 psi (0-10 MPa)	SGI-F2924N	0-20000 psi (0-140 MPa)
SGI-F1424N	0-2000 psi (0-14 MPa)		
SGI-F1524N	0-3000 psi (0-20 MPa)		

2.5" Stainless Steel Industrial Pressure Gages

1.6% Full Scale Accuracy, 316 SS or Brass Wetted Parts

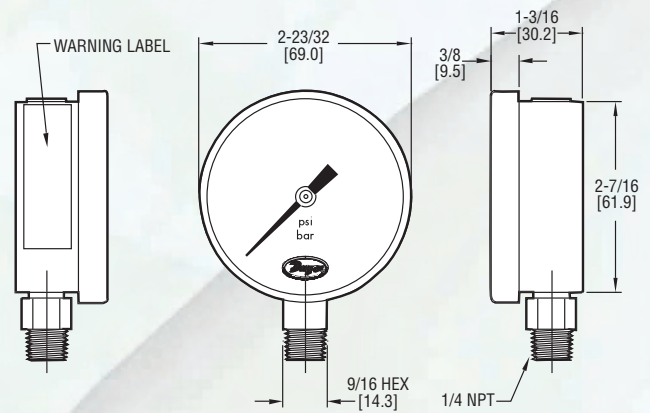

The Series SGD/SGT Gages have dual English/metric scales with $\pm 1.6\%$ full scale accuracy. The Series SGD/SGT gages are designed with 304 SS housings and 316 SS or brass wetted parts for excellent chemical compatibility. These gages cover a wide variety of ranges from full vacuum to 15,000 psi. Series SGD/SGT gages may be easily liquid filled in the field without the need for a sperate kit.

APPLICATIONS

- Vacuums in pneumatic conveying lines.
- Positive Pressures in compressed air headers.

SPECIFICATIONS

Service: Compatible gases and liquids.

Wetted Materials: SGD: 316 SS; SGT: Brass.

Housing: 304 SS.

Lens: Plexi-glass.

Accuracy: $\pm 1.6\%$ full scale.

Pressure Limit: 130% full scale for ranges <6000 psi, 115% for 6000 psi and greater.

Temperature Limits:

SGD: Ambient: -4 to 149°F (-25 to 65°C), Process: 518°F max. (270°C max.);

SGT: Ambient: -4 to 140°F (-20 to 60°C), Process: 248°F max. (120°C max.).

Size: 2.5" (63 mm).

Process Connections: 1/4" male NPT.

Enclosure Rating: NEMA 3 (IP55).

Weight: 4.6 oz (0.13 kg).

Model Number	Ranges	Model Number	Ranges
SGD-D0122N	30" Hg-0 (-100-0 kPa)	SGT-D0122N	30" Hg-0 (-100-0 kPa)
SGD-D0222N	0-15 psi (0-100 kPa)	SGT-D0222N	0-15 psi (0-100 kPa)
SGD-D0322N	0-30 psi (0-200 kPa)	SGT-D0322N	0-30 psi (0-200 kPa)
SGD-D0422N	0-60 psi (0-400 kPa)	SGT-D0422N	0-60 psi (0-400 kPa)
SGD-D0522N	0-100 psi (0-700 kPa)	SGT-D0522N	0-100 psi (0-700 kPa)
SGD-D0622N	0-150 psi (0-1000 kPa)	SGT-D0622N	0-150 psi (0-1000 kPa)
SGD-D0722N	0-200 psi (0-1400 kPa)	SGT-D0722N	0-200 psi (0-1400 kPa)
SGD-D0822N	0-300 psi (0-2000 kPa)	SGT-D0822N	0-300 psi (0-2000 kPa)
SGD-D0922N	0-400 psi (0-2800 kPa)	SGT-D0922N	0-400 psi (0-2800 kPa)
SGD-D1022N	0-500 psi (0-3400 kPa)	SGT-D1022N	0-500 psi (0-3400 kPa)
SGD-D1122N	0-600 psi (0-4000 kPa)	SGT-D1122N	0-600 psi (0-4000 kPa)
SGD-D1222N	0-1000 psi (0-7000 kPa)	SGT-D1222N	0-1000 psi (0-7000 kPa)
SGD-D1322N	0-1500 psi (0-10 MPa)	SGT-D1322N	0-1500 psi (0-10 MPa)
SGD-D1422N	0-2000 psi (0-14 MPa)	SGT-D1422N	0-2000 psi (0-14 MPa)
SGD-D1522N	0-3000 psi (0-20 MPa)	SGT-D1522N	0-3000 psi (0-20 MPa)
SGD-D1622N	0-4000 psi (0-28 MPa)	SGT-D1622N	0-4000 psi (0-28 MPa)
SGD-D1722N	0-5000 psi (0-34 MPa)	SGT-D1722N	0-5000 psi (0-34 MPa)
SGD-D1822N	0-6000 psi (0-40 MPa)	SGT-D1822N	0-6000 psi (0-40 MPa)
SGD-D2122N	30" Hg-0-15 psi (-100-0-100 kPa)	SGT-D2122N	30" Hg-0-15 psi (-100-0-100 kPa)
SGD-D2222N	30" Hg-0-30 psi (-100-0-200 kPa)	SGT-D2222N	30" Hg-0-30 psi (-100-0-200 kPa)
SGD-D2322N	30" Hg-0-60 psi (-100-0-400 kPa)	SGT-D2322N	30" Hg-0-60 psi (-100-0-400 kPa)
SGD-D2422N	30" Hg-0-100 psi (-100-0-700 kPa)	SGT-D2422N	30" Hg-0-100 psi (-100-0-700 kPa)
SGD-D2522N	30" Hg-0-150 psi (-100-0-1000 kPa)	SGT-D2522N	30" Hg-0-150 psi (-100-0-1000 kPa)
SGD-D2622N	30" Hg-0-200 psi (-100-0-1400 kPa)	SGT-D2622N	30" Hg-0-200 psi (-100-0-1400 kPa)
SGD-D2722N	30" Hg-0-300 psi (-100-0-2000 kPa)	SGT-D2722N	30" Hg-0-300 psi (-100-0-2000 kPa)

Series
SGS

4" Stainless Steel Industrial Pressure Gage

1.6% Full Scale Accuracy, Brass Wetted Parts

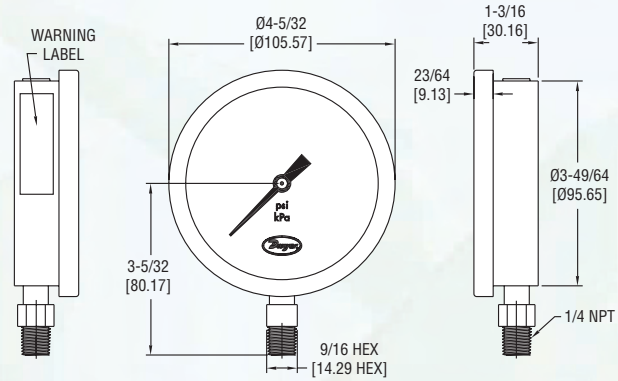

The Series SGS Gages have dual English/metric scales with $\pm 1.6\%$ full scale accuracy. Series SGS gages are designed with 304 SS housings and brass wetted parts. Units can withstand ambient temperatures up to 149°F (65°C) and process temperatures up to 257°F (125°C). These gages may be easily liquid filled in the field without the need for a separate kit. A wide selection of ranges are available from full vacuum, compound to 15,000 psi.

APPLICATIONS

Pneumatics and Compressors.

SPECIFICATIONS

Service: Compatible gases and liquids.

Wetted Materials: Brass for ranges ≤ 1000 psi; 316L SS for ranges greater than 1000 psi.

Housing: 304 SS.

Lens: Plexi-glass.

Accuracy: $\pm 1.6\%$ full scale.

Pressure Limits: 125% full scale for ranges < 1500 psi; 115% for ranges 1500 psi and greater.

Temperature Limits:

Ambient: -4 to 149°F (-20 to 65°C);

Process: 257°F max. (125°C max.).

Size: 4" (100 mm).

Process Connection: 1/4" male NPT.

Enclosure Rating: NEMA 3 (IP55).

Weight: 1.1 lb (0.49 kg).

Model Number	Ranges	Model Number	Ranges
SGS-F0122N	30" Hg-0 (-100-0 kPa)	SGS-F1622N	0-4000 psi (0-28 MPa)
SGS-F0222N	0-15 psi (0-100 kPa)	SGS-F1722N	0-5000 psi (0-34 MPa)
SGS-F0322N	0-30 psi (0-200 kPa)	SGS-F1822N	0-6000 psi (0-40 MPa)
SGS-F0422N	0-60 psi (0-400 kPa)	SGS-F1922N	0-10000 psi (0-70 MPa)
SGS-F0522N	0-100 psi (0-700 kPa)	SGS-F2122N	30" Hg-0-15 psi (-100-0-100 kPa)
SGS-F0622N	0-150 psi (0-1000 kPa)	SGS-F2222N	30" Hg-0-30 psi (-100-0-200 kPa)
SGS-F0722N	0-200 psi (0-1400 kPa)	SGS-F2322N	30" Hg-0-60 psi (-100-0-400 kPa)
SGS-F0822N	0-300 psi (0-2000 kPa)	SGS-F2422N	30" Hg-0-100 psi (-100-0-700 kPa)
SGS-F0922N	0-400 psi (0-2800 kPa)	SGS-F2522N	30" Hg-0-150 psi (-100-0-1000 kPa)
SGS-F1022N	0-500 psi (0-3400 kPa)	SGS-F2622N	30" Hg-0-200 psi (-100-0-1400 kPa)
SGS-F1122N	0-600 psi (0-4000 kPa)	SGS-F2722N	30" Hg-0-300 psi (-100-0-2000 kPa)
SGS-F1222N	0-1000 psi (0-7000 kPa)		
SGS-F1322N	0-1500 psi (0-10 MPa)		
SGS-F1422N	0-2000 psi (0-14 MPa)		
SGS-F1522N	0-3000 psi (0-20 MPa)		

Series
763
&
764

Field-Fillable & Glycerin-Filled Process Gages

0.5% Accuracy, Internal Over and Under Load Protection

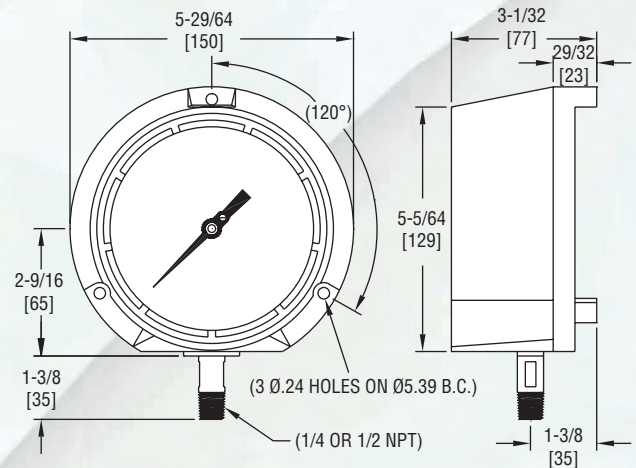

The Series 763/764 Process Gages possess psi scales with 0.5% full scale ANSI B40.1 Grade 2A accuracy. The 763/764 gages are designed with a Phenolic safety-case. This safety-case has a solid front with blow-out back. Internal overload and under-load protection is provided to prevent damage to the gage from extreme over or under range sensing. Access to the adjustable needle pointer is simple via the removable bezel. Series 763 units are shipped dry, but can be easily liquid-filled in the field without the need for a separate kit. Series 764 units contain glycerin fill which allows the gages to be used in high vibration applications. Excellent chemical compatibility is obtained with the 316 SS socket and Bourdon tube. A wide offering of ranges are available from full vacuum, compound to 20,000 psi. The 763/764 is typically used to monitor suction pressures on the blower.

SPECIFICATIONS

Service: Compatible gases and liquids.

Wetted Materials: 316 SS socket and Bourdon tube.

Housing: Phenolic.

Lens: Polycarbonate.

Fill: Glycerin (764 only).

Accuracy: 0.5% full scale ANSI B40.1 Grade 2A.

Pressure Limit: 110% of full scale.

Temperature Limits: 763: -40 to 160°F (-40 to 71°C); 764: 30 to 160°F (-1 to 71°C).

Size: 4.5" (115 mm).

Process Connection: 1/4" or 1/2" male NPT lower.

Weight: 763: 31.36 oz (0.9 kg); 764: 41.6 oz (1.18 kg).

Model Number (1/4" NPT)	Ranges	Model Number (1/2" NPT)	Ranges
763-012N	30" Hg - 0	763-014N	30" Hg - 0
763-022N	0-15 psi	763-024N	0-15 psi
763-032N	0-30 psi	763-034N	0-30 psi
763-042N	0-60 psi	763-044N	0-60 psi
763-052N	0-100 psi	763-054N	0-100 psi
763-062N	0-160 psi	763-064N	0-160 psi
763-072N	0-200 psi	763-074N	0-200 psi
763-082N	0-300 psi	763-084N	0-300 psi
763-092N	0-400 psi	763-094N	0-400 psi
763-112N	0-600 psi	763-114N	0-600 psi
763-122N	0-1000 psi	763-124N	0-1000 psi
763-132N	0-1500 psi	763-134N	0-1500 psi
763-142N	0-2000 psi	763-144N	0-2000 psi
763-152N	0-3000 psi	763-154N	0-3000 psi
763-172N	0-5000 psi	763-174N	0-5000 psi
763-192N	0-10000 psi	763-194N	0-10000 psi
763-212N	30" Hg-0-15 psi	763-204N	0-15000 psi
763-222N	30" Hg-0-30 psi	763-294N	0-20000 psi
763-232N	30" Hg-0-60 psi	763-214N	30" Hg-0-15 psi
763-242N	30" Hg-0-100 psi	763-224N	30" Hg-0-30 psi
763-252N	30" Hg-0-160 psi	763-234N	30" Hg-0-60 psi
763-262N	30" Hg-0-200 psi	763-244N	30" Hg-0-100 psi
763-272N	30" Hg-0-300 psi	763-254N	30" Hg-0-160 psi
		763-264N	30" Hg-0-200 psi
		763-274N	30" Hg-0-300 psi

For glycerin fill change series from 763 to 764.

Series
TPG

Temperature & Pressure Gage

Eliminates Need for Two Separate Gages

Pressure Gages

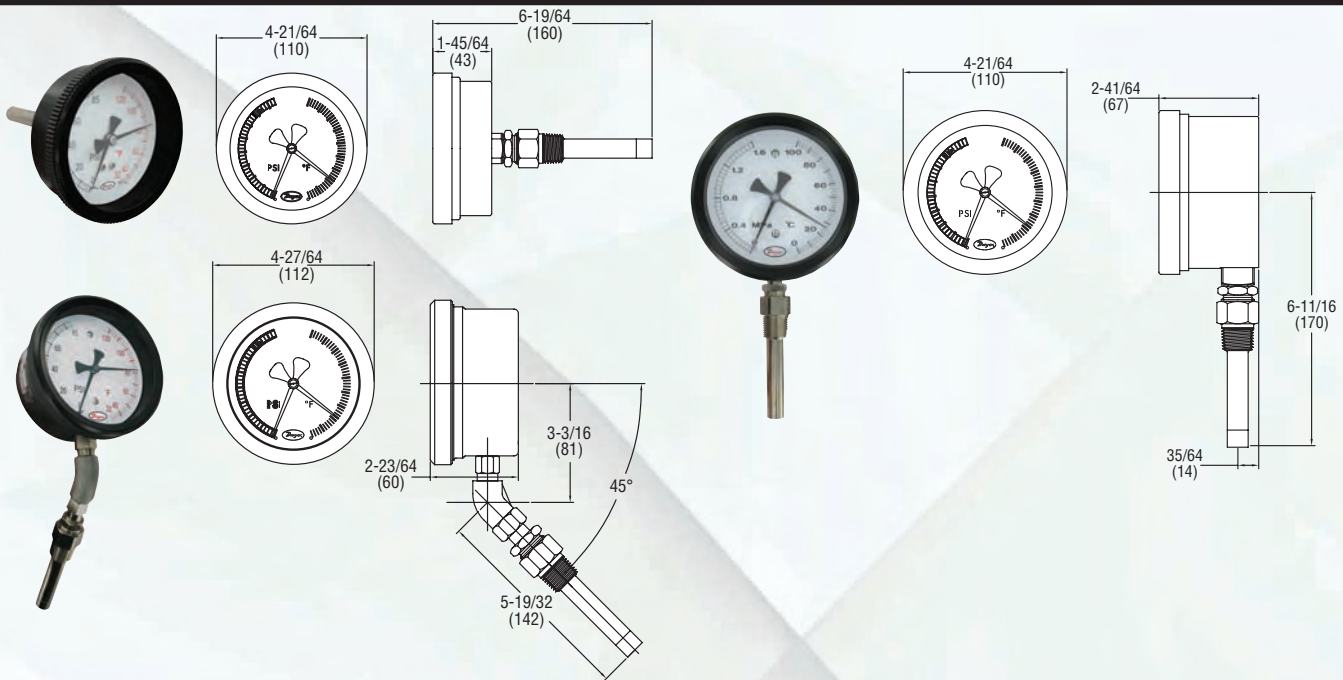

The Series TPG Temperature & Pressure Gage eliminates the need for two separate temperature and pressure gages. Unique internal valve depressor built into the well allows the gage's sensing probe to be easily removed from the thermowell without causing leakage, eliminating downtime. Installation time is further reduced via one connection to pipe instead of two.

Series TPG is packaged in an ABS plastic case. Models are available with a back mount, direct bottom mount, 45° bottom mount or panel or surface mount with capillary. Side by side pressure and temperature scales allow quick and easy readings. Series TPG has a temperature accuracy of 2% and a pressure accuracy of 1.6% of full scale. Intended for industrial or HVAC applications, specifically measuring water in air conditioners and heat ventilation systems.

APPLICATIONS

Air line temperatures and pressures.

SPECIFICATIONS

Service: Clean water and compatible gases.

Wetted Materials: Brass, 304 SS.

Housing Materials: ABS Plastic.

Accuracy: Pressure $\pm 1.6\%$ FS; Temperature $\pm 2.0\%$ FS.

Pressure Limits: 150% FS. Normal operation should be between 10% and 90% of full scale.

Temperature Limits: Ambient: -4 to 140°F (-20 to 60°C); Process: Within range.

Humidity Limit: Ambient not to exceed 80%.

Size: TPG-BA/TPG-BO: 4.33" (110 mm) casing, 3.54" (90 mm) dial; TPG-45: 4.41" (112 mm) casing, 3.66" (93 mm) dial.

Process Connections: 1/2" male NPT.

Mounting Orientation: Dial face in vertical position.

Weight: 15.2 oz (431 g).

Model (Back Mount)	Description	Model (Bottom Mount)	Description	Model (45° Mount)	Description
TPG-BA-01-065	85 psi/120°F	TPG-BO-01-065	85 psi/120°F	TPG-45-01-065	85 psi/120°F
TPG-BA-02-065	85 psi/210°F	TPG-BO-02-065	85 psi/210°F	TPG-45-02-065	85 psi/210°F
TPG-BA-03-065	150 psi/120°F	TPG-BO-03-065	150 psi/120°F	TPG-45-03-065	150 psi/120°F
TPG-BA-04-065	150 psi/210°F	TPG-BO-04-065	150 psi/210°F	TPG-45-04-065	150 psi/210°F
TPG-BA-05-065	235 psi/120°F	TPG-BO-05-065	235 psi/120°F	TPG-45-05-065	235 psi/120°F
TPG-BA-06-065	235 psi/210°F	TPG-BO-06-065	235 psi/210°F	TPG-45-06-065	235 psi/210°F
TPG-BA-07-065	6 bar/50°C	TPG-BO-07-065	6 bar/50°C	TPG-45-07-065	6 bar/50°C
TPG-BA-08-065	6 bar/100°C	TPG-BO-08-065	6 bar/100°C	TPG-45-08-065	6 bar/100°C
TPG-BA-09-065	10 bar/50°C	TPG-BO-09-065	10 bar/50°C	TPG-45-09-065	10 bar/50°C
TPG-BA-10-065	10 bar/100°C	TPG-BO-10-065	10 bar/100°C	TPG-45-10-065	10 bar/100°C
TPG-BA-11-065	16 bar/50°C	TPG-BO-11-065	16 bar/50°C	TPG-45-11-065	16 bar/50°C
TPG-BA-12-065	16 bar/100°C	TPG-BO-12-065	16 bar/100°C	TPG-45-12-065	16 bar/100°C

ACCESSORY

A-167, Spare Thermowell

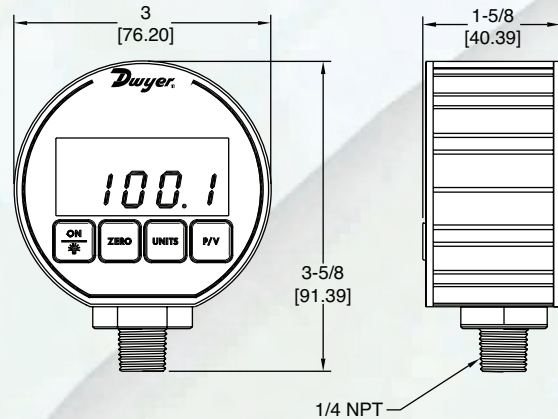

Replace your outdated analog gages with the new **Series DPG-100 Digital Pressure Gage**. The Series DPG-100 has a high $\pm 0.25\%$ full scale accuracy. The 4 digit digital display will reduce the potential for errors in readings by eliminating parallax error commonly produced with analog gages.

Series DPG-100 is battery powered and has an auto-shut off to conserve battery life. Battery life, on average, will last 2000 hours. A 4 button key pad allows easy access to features without the need to work through complex menus or difficult key combinations. These features include back-light, peak and valley, tare or auto zero and conversion of the pressure units.

APPLICATIONS

- Checking process pressures at system start-up.
- Validating performance of mechanical gages in the plant.

SPECIFICATIONS

Service: Compatible liquids and gases (for FM listing see Agency Approvals below).

Wetted Materials: Type 316L SS.

Housing Materials: Black Polycarbonate front & back cover, anodized aluminum extruded housing with recessed grooves, Polycarbonate overlay, Buna-N O-rings, 316L SS sensor construction.

Accuracy: 0.25% F.S. +/- 1 least significant digit @ 70°F (21°C) (Includes linearity, hysteresis, repeatability).

Pressure Limit: 2x pressure range for models ≤ 1000 psi; 5000 psi for 3000 psi range; 7500 psi for 5000 psi range.

Enclosure Rating: Designed to meet NEMA 4/4X (IP66).

Temperature Limits: 0 to 130°F (-18 to 55°C).

Thermal Effect: Between 70 to 130°F is 0.016%/F.

Between 32 to 70°F is 0.026%/F. Between 10 to 32°F is 0.09%/F.

Size: 3.00" OD x 1.90 deep (max).

Process Connection: 1/4" male NPT.

Weight: 8.84 oz (275 g).

Display: 4 digit (.425 H x .234 W digits).

Power Requirements: Two AAA batteries.

Battery Life: 2000 hours typical; Low battery indicator.

Auto Shut-Off:

Gage: 60 minute auto shut off. Auto shut-off may be disengaged.

Backlight: 2 minute auto shut-off.

Agency Approvals: CE, FM approved to be intrinsically safe for Class I, Division I, Groups A, B, C and D, for ranges 0-15 to 0-3000 psi.

Model Number	Range psi	Pressure Ranges									
		kg/cm ²	bar	in Hg	ft wc	kPa	oz/in ²	in wc	mbar	cm wc	mm Hg
DPG-100*	-14.70-0	-1.033	-1.013	-29.93	-33.94	-101.4	-235.2	-407.3	-1013	-1034	-760.7
DPG-102	15.00	1.055	1.034	30.54	34.61	103.4	240	415.2	1034	1055	775.7
DPG-103	30.00	2.109	2.069	61.08	69.21	206.9	480	830.4	2069	2109	1551
DPG-104	50.00	3.515	3.448	101.8	115.4	344.8	800	1384	3448	3515	2586
DPG-105	100.0	7.03	6.895	203.6	230.7	689.5	1600	2768	6895	7031	5172
DPG-106	200.0	14.06	13.79	407.2	461.4	1379	3200	5536			
DPG-107	300.0	21.09	20.69	610.8	692.1	2069	4800	8304			
DPG-108	500.0	35.15	34.48	1018	1154	3448	8000				
DPG-109	1000	70.3	68.98	2036	2307	6895					
DPG-110	3000	210.9	206.9	6108	6921						
DPG-111*	5000	351.5	344.8								

Compound Ranges Available: DPG-120* Range: 30" Hg-0-15 psi; DPG-121* Range: 30" Hg-0-30 psi; DPG-122* Range: 30" Hg-0-45 psi; DPG-123*: Range 30" Hg-0-60 psi; DPG-124*: 30" Hg-0-100 psi.

* Models DPG-100, DPG-111, DPG-120, DPG-121, DPG-122, DPG-123 and DPG-124 are not FM approved.



DPGA



DPGW

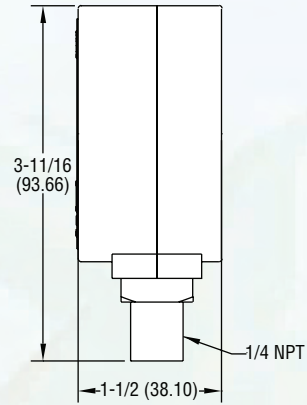
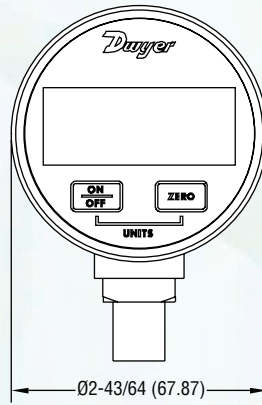

The Series DPGA is the only economic digital pressure gage with selectable engineering units on the market. With its 1% accuracy and digital push-button zero, the DPGA is the perfect choice for digitally monitoring the pressures of air and compatible gases.

The Series DPGW is the only economic digital pressure gage for liquids with the ability to select engineering units on the market. With its 1% accuracy and digital push-button zero, the DPGW is the perfect choice for digitally monitoring the pressures of compatible liquids and gases. Ideal for checking process pressures at system start-up.

SPECIFICATIONS

Service: DPGA: Air and compatible gases; DPGW: Liquids and compatible gases.

Wetted Materials: DPGA: 316L SS, Silicone sensor; DPGW: 316L SS.

Housing Materials: ABS plastic.

Accuracy: ±1.0% F.S. (Includes linearity, hysteresis, repeatability).

Pressure Limits: 2X pressure range. Vacuum range max. pressure is 30 psig.

Temperature Limits: 30 to 120°F (-1 to 49°C).

Thermal Effect: 0.05% FS/°F.

Size: 2.62" O.D. x 1.52" deep.

Process Connections: 1/4" male NPT.

Display: 4-digit LCD (.425" H x .234" W digits).

Power Requirements: 9 volt alkaline battery. Battery included but not connected.

Auto Shut-off: 20 minute auto shut-off.

Weight: 5.6 oz (160 g).

Agency Approvals: CE.

Model Number	Range	Pressure Ranges											Resolution psi
		psi	kg/cm ²	bar	in Hg	ft wc	kPa	oz/in ²	in wc	mbar	cm wc	mm Hg	
DPGA-00	30" Hg to 0 (vac)	-14.70	-1.033	-1.013	-29.93	-33.94	-101.4	-235.2	-407.3	-1013	-1034	-761	0.01
DPGA-01	0 to 20" w.c.	0.722	.0508	.0498	1.471	1.667	4.980	11.55	20.00	49.80	50.8	37.37	0.001
DPGA-02	0 to 1 psi	1.000	.0703	.0689	2.036	2.307	6.89	16.00	27.68	68.9	70.3	51.7	0.001
DPGA-03	0 to 2 psi	2.000	.1406	.1379	4.072	4.614	13.79	32.00	55.4	137.9	140.6	103.4	0.001
DPGA-04	0 to 5 psi	5.000	.3515	.3447	10.18	11.53	34.47	80.0	138.4	344.7	351.5	258.6	0.002
DPGA-05	0 to 15 psi	15.00	1.055	1.034	30.54	34.60	103.4	240.0	415.2	1034	1055	776	0.01
DPGA-06	0 to 30 psi	30.00	2.109	2.068	61.1	69.2	206.8	480.0	830	2068	2109	1551	0.01
DPGA-07	0 to 50 psi	50.00	3.515	3.447	101.8	115.3	344.7	800	1384	3447	3515	2586	0.02
DPGA-08	0 to 100 psi	100.0	7.03	6.89	203.6	230.7	689	1600	2768				0.1
DPGA-09	0 to 200 psi	200.0	14.06	13.79	407.2	461.3	1379	3200					0.1
DPGA-10	0 to 300 psi	300.0	21.09	20.68	611	692	2068	4800					0.1
DPGA-11	0 to 500 psi	500.0	35.15	34.47	1018	1153	3447						0.2

Model Number	Range	Pressure Ranges											Resolution psi
		psi	kg/cm ²	bar	in Hg	ft wc	kPa	oz/in ²	in wc	mbar	cm wc	mm Hg	
DPGW-00	30" Hg to 0 (vac)	-14.70	-1.033	-1.013	-29.93	-33.94	-101.4	-235.2	-407.3	-1013	-1034	-761	0.01
DPGW-04	0 to 5 psi	5.000	.3515	.3447	10.18	11.53	34.47	80.0	138.4	344.7	351.5	258.6	0.002
DPGW-05	0 to 15 psi	15.00	1.055	1.034	30.54	34.60	103.4	240.0	415.2	1034	1055	776	0.01
DPGW-06	0 to 30 psi	30.00	2.109	2.068	61.1	69.2	206.8	480.0	830	2068	2109	1551	0.01
DPGW-07	0 to 50 psi	50.00	3.515	3.447	101.8	115.3	344.7	800	1384	3447	3515	2586	0.02
DPGW-08	0 to 100 psi	100.0	7.03	6.89	203.6	230.7	689	1600	2768				0.1
DPGW-09	0 to 200 psi	200.0	14.06	13.79	407.2	461.3	1379	3200					0.1
DPGW-10	0 to 300 psi	300.0	21.09	20.68	611	692	2068	4800					0.1
DPGW-11	0 to 500 psi	500.0	35.15	34.47	1018	1153	3447						0.2

Compound Range Available: DPGW-12 30" Hg-0-100 psi

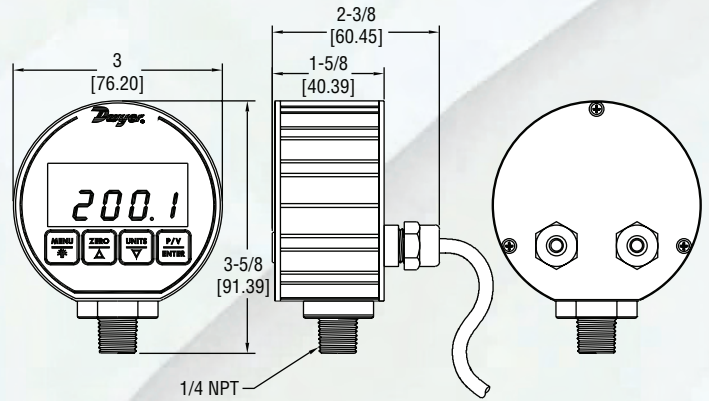

The Series DPG-200 Digital Pressure Gage has a precise $\pm 0.25\%$ full scale accuracy. The 4 digit digital display will reduce the potential for errors in readings by eliminating parallax error commonly produced with analog gages. The DPG-200 is packaged in a durable extruded aluminum case designed to meet NEMA 4X (IP66). The unit is powered by 12-24 VDC/VAC and contains two alarm set points along with a 4-20 mA process output. A four-button keypad allows easy access to features. These features include backlight, peak and valley, auto zero and conversion of the pressure units.

APPLICATIONS

- Process Control
- Compressor Control

SPECIFICATIONS

DIGITAL GAGE SPECIFICATIONS

Service: Liquids and non-combustible compatible gases.

Wetted Materials: Type 316L SS.

Housing: Black polycarbonate front & back cover, anodized aluminum extruded housing with recessed grooves, polycarbonate overlay, Buna-N O-rings, 316L SS sensor construction.

Accuracy: 0.25% F.S. ± 1 least significant digit. (Includes linearity, hysteresis, repeatability).

Pressure Limit: 2x pressure range for models 1000 psi; 5000 psi for 3000 psi range; 7500 psi for 5000 psi range.

Temperature Limits: 0 to 158°F (0 to 70°C).

Process Connection: 1/4" male NPT.

Display: 4 digit (.425" H x .234" W digits).

Size: 3.00" OD x 1.90" deep (not including cables).

Weight: 8.84 oz (275 g).

SWITCH SPECIFICATIONS

Switch Type: 2 SPDT Form C contacts.

Electrical Rating: 0.5A @ 125 VAC resistive, 1A @ 24 VDC.

Relay Differential: 1 least significant digit.

Electrical Connections: 3 ft (.91 m) cable.

Mounting Orientation: Mount in any position.

Set Point Adjustment: Via menu.

TRANSMITTER SPECIFICATIONS

Temperature Limits: 0 to 158°F (0 to 70°C).

Thermal Effect: Between 70 to 158°F = 0.016%/°F.

Between 0 to 70°F = 0.026%/°F.

Power Requirements: 12-24 VAC +/- 20% 50-400 HZ, 12-24 VDC +/-20%.

Output Signal: 4-20 mA.

Loop Resistance: 600 ohms maximum.

Power Consumption: 0.8 W max.

Electrical Connections: 3 ft (.91 m) cable.

Enclosure Rating: Designed to meet NEMA 4X (IP66).

Agency Approvals: CE.

Model Number	Range psi	Pressure Ranges										
		kg/cm ²	bar	in Hg	ft wc	ft sw*	kPa	oz/in ²	in wc	mbar	cm wc	mm Hg
DPG-200	-14.70-0	-1.033	-1.013	-29.93	-33.94	-33.06	-101.4	-235.2	-407.3	-1013	-1034	-760.7
DPG-202	15.00	1.055	1.034	30.54	34.61	33.73	103.4	240	415.2	1034	1055	775.7
DPG-203	30.00	2.109	2.069	61.08	69.21	67.45	206.9	480	830.4	2069	2109	1551
DPG-204	50.00	3.515	3.448	101.8	115.4	112.4	344.8	800	1384	3448	3515	2586
DPG-205	100.0	7.03	6.895	203.6	230.7	224.8	689.5	1600	2768	6895	7031	5172
DPG-206	200.0	14.06	13.79	407.2	461.4	449.7	1379	3200	5536			
DPG-207	300.0	21.09	20.69	610.8	692.1	674.5	2069	4800	8304			
DPG-208	500.0	35.15	34.48	1018	1154	1124	3448	8000				
DPG-209	1000	70.3	68.98	2036	2307	2248	6895					
DPG-210	3000	210.9	206.9	6108	6921	6745						
DPG-211	5000	351.5	344.8									

Compound Ranges Available: DPG-220 Range: 30" Hg-0-15 psi.

*feet of seawater @ 4°C

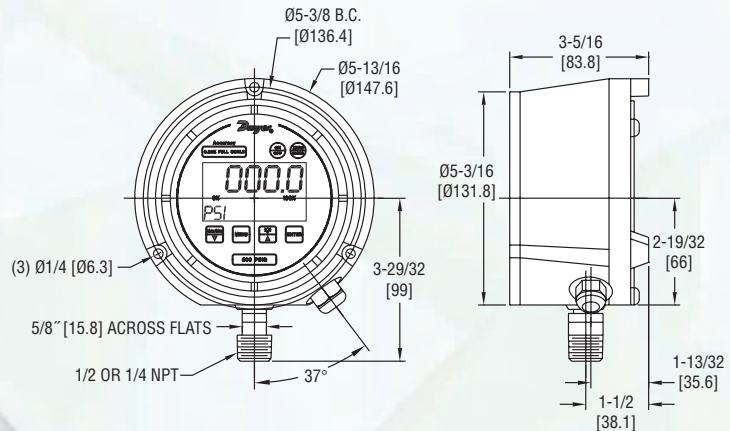

The Series DSGT Digital Indicating Transmitter is a versatile multi-function process gage that features an excellent 0.25% full scale accuracy. This all-in-one digital gage package is designed to reduce installation costs, instrument cost, and save space where an application requires a gage, transmitter, and switches. The Series DSGT gage comes standard with a loop-powered 4-20 mA transmitter output and is offered with one or two optional SPDT switches.

The Series DSGT gage is housed in a durable fiberglass reinforced thermoplastic case that is designed to meet NEMA 4 (IP65) requirements. The gage features a menu-driven display for easy customization. User selectable features include 12 engineering units of measure, password protected calibration and disable functions, as well as an adjustable bar graph and update/dampening rates.

- DSGT-XXX-C0S**, Transmitter with No Switch Outputs
- DSGT-XXX-C1S**, Transmitter with 1 SPDT Switch Output
- DSGT-XXX-C2S**, Transmitter with 2 SPDT Switch Outputs

Model Number*	Range	Model Number*	Range
DSGT-101-C0S	30" Hg-0-15 psig	DSGT-111-C0S	0-800 psig
DSGT-102-C0S	30" Hg-0-30 psig	DSGT-112-C0S	0-1000 psig
DSGT-103-C0S	30" Hg-0-60 psig	DSGT-113-C0S	0-1500 psig
DSGT-104-C0S	0-30 psig	DSGT-114-C0S	0-2000 psig
DSGT-105-C0S	0-60 psig	DSGT-115-C0S	0-3000 psig
DSGT-106-C0S	0-100 psig	DSGT-116-C0S	0-5000 psig
DSGT-107-C0S	0-160 psig	DSGT-117-C0S	0-8000 psig
DSGT-108-C0S	0-200 psig	DSGT-118-C0S	0-10,000 psig
DSGT-109-C0S	0-300 psig	DSGT-119-C0S	0-15,000 psig
DSGT-110-C0S	0-600 psig	DSGT-120-C0S	0-20,000 psig

*For optional switch outputs change -C0S suffix to -C1S for 1 SPDT switch, or -C2S for 2 SPDT switches.

SPECIFICATIONS

GAGE SPECIFICATIONS

- Service:** Compatible, non-combustible liquids & gases.
- Wetted Materials:** 17-4 stainless steel sensor, 316 SS socket.
- Housing Materials:** Fiberglass reinforced thermoplastic case.
- Accuracy:** 0.25% full scale (Includes linearity, hysteresis, repeatability).
- Pressure Limit:** 2 x full scale range.
- Process Connection:** 1/2" male NPT.
- Display:** 5 Digit (0.88" high).

TRANSMITTER SPECIFICATIONS

- Power Supply:** 12-36 VDC (Loop Powered).
- Output Signal:** 4-20 mA.
- Response Time:** 100 ms.
- Temperature Limits:** 14 to 140°F (-10 to 60°C).
- Thermal Effects:** 0.04% full scale/°F.
- Electrical Connections:** 3 ft flying leads.
- Loop Resistance:** DC; 0-1090 ohms maximum.
- Set Point Adjustments:** Adjustable through menu selections.
- Weight:** 1.45 lb (.66 kg).
- Agency Approvals:** CE.

SWITCH SPECIFICATIONS (OPTIONAL)

- Switch Type:** 1 SPDT (-C1S option); 2 SPDT (-C2S option).
- Repeatability:** 0.25% full scale.
- Electrical Rating:** 1A @ 24 VDC or 0.5A @ 125 VAC.
- Electrical Connections:** 3 ft flying leads.
- Power Requirements:** 12-36 VDC (Separate line power).
- Enclosure Rating:** NEMA 4X (IP66).

Hi/Lo Limit Control Initiates Dust Collector Cleaning Cycles



Set points are instantly adjusted with front knobs.

Photohelic® Switch/Gages function as versatile, highly repeatable pressure switches combined with a precise pressure gage employing the time-proven Magnehelic® gage design. The low cost Photohelic® gage measures and controls positive, negative or differential pressures of air and compatible gases. Standard models are rated to 25 psig (1.7 bar) with options to 35 (2.4) or 80 (5.5 bar) psig. The Photohelic® Switch/Gages have been utilized for years as Hi/Lo limit controls combined with a timer board to provide on-demand cleaning in dust filtration systems.

OPTIONS

Single contact, right set point, for actuation on increasing or decreasing pressure.

OEM Model, less relay and transformer components and housing but including infrared diodes and phototransistor(s), light shutter and set pointer(s). For single or double contact.

Remote-Mounted Relay, relay pack may be mounted remotely from gage. Specify cable length required.

Tamper-proof knobs, low temperature option, special scales, voltages and other features and modifications are available.

Special Housings available include Weatherproof (NEMA 4) and Explosion-proof (NEMA 7 CD, 9 EFG; NEC Class I, DIV. 1 & 2, Groups C, D, Class II, Div. 1 & 2, Groups E, F, G, Class III end). Contact Customer Service for detailed dimension drawings.

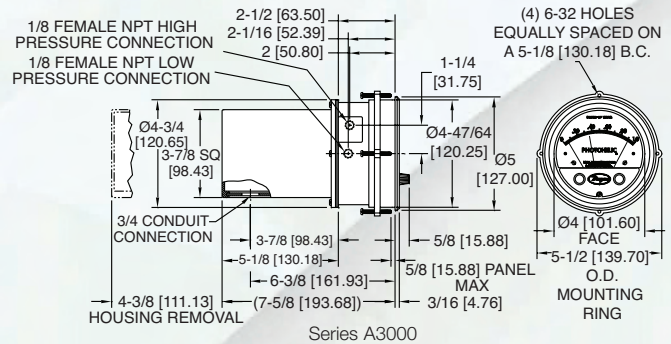

SPECIFICATIONS

GAGE SPECIFICATIONS

Service: Air and non-combustible, compatible gases.

Wetted Materials: Consult factory.

Accuracy: ±2% of full scale at 70°F (21.1°C). ±3% on -0 and ±4% on -00 models.

Pressure Limits: -20" Hg. to 25 psig (-0.677 to 1.72 bar). MP option; 35 psig (2.41 bar), HP option; 80 psig (5.52 bar).

Temperature Limits: 20 to 120°F (-6.67 to 48.9°C) low temperature option available.

Process Connections: 1/8" female NPT.

Size: 4" (101.6 mm) dial face. 5" (127 mm) O.D. x 8-1/4" (209.55 mm).

Weight: 4 lb (1.81 kg).

SWITCH SPECIFICATIONS

Switch Type: Each setpoint has 2 Form C relays (DPDT).

Repeatability: ±1% of full scale.

Electrical Rating: 10A @ 28 VDC, 10A @ 120, 240 VAC.

Electrical Connections: Screw terminals. Use 167°F (75°C) copper conductors only.

Power Requirements: 120 VAC, 50/60 Hz; 240 VAC & 24 VAC Power optional.

Mounting Orientation: Diaphragm in vertical position. Consult factory for other position orientations.

Set Point Adjustment: Adjustable knobs on face.

Agency Approvals: UL, CSA, CE.

Model Number	Range, In W.C.	Model Number	Range, PSI	Model Number	Range, MM W.C.	Model Number	Range, Pascals
A3000-00	0-.25	A3201	0-1	A3000-6MM	0-6	A3000-60PA	0-60
A3000-0	0-.50	A3202	0-2	A3000-10MM	0-10	A3000-125PA	0-125
A3001	0-1.0	A3203	0-3	A3000-25MM	0-25	A3000-250PA	0-250
A3002	0-2.0	A3204	0-4	A3000-50MM	0-50	A3000-500PA	0-500
A3003	0-3.0	A3205	0-5	A3000-80MM	0-80	A3000-750PA	0-750
A3004	0-4.0	A3210**	0-10	A3000-100MM	0-100		
A3005	0-5.0	A3215**	0-15				
A3006	0-6.0	A3220**	0-20				
A3008	0-8.0	A3230***	0-30				
A3010	0-10	** MP or *** HP option standard					
A3015	0-15	Options and Accessories — Add options as a suffix. Example: A3001-LT -SRH, Single Relay Activates on Increase -MP, Medium pressure -SRL, Single Relay Activates on Decease -HP, High pressure -OLS, OEM model -LT, Low temperature (-20°F) -RMR, Remote mounted relay A-298, Flat Flush Mounting Bracket -TAMP, Tamper proof knobs A-601, Manual reset switch					
A3020	0-20						
A3025	0-25						
A3030	0-30						
A3040	0-40						
A3050	0-50						
A3060	0-60						
A3080	0-80						
A3100	0-100						
A3150	0-150						

Series
3000MR
3000MRS

Photohelic® Switch/Gages



Hi/Lo Limit Control for On-Demand Cleaning

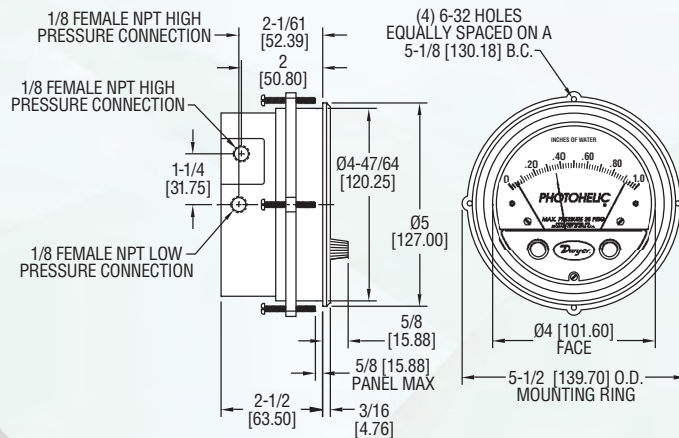

SPECIFICATIONS

GAGE SPECIFICATIONS

Service: Air and non-combustible, compatible gases.

Wetted Materials: Consult factory.

Accuracy: ±2% of full scale (3000-0 ±3% of full scale). (3000-00 ±4% of full scale.)

Pressure Limit: -20" Hg. to 25 psig (-0.677 bar to 1.72 bar). MP option; 35 psig (2.41 bar), HP option; 80 psig (5.52 bar).

Temperature Limits: 20 to 120°F (-6.67 to 48.9°C).

Process Connections: 1/8 female NPT (duplicated side and back).

Size: 4" (101.6 mm) dial face, 5" (127 mm) O.D. x 3-1/8" (79.38 mm).

Weight: 1.8 lb (816 g).

SWITCH SPECIFICATIONS 3000MR

Switch Type: Each setpoint has 1 Form C relays (SPDT).

Relay Contacts: (resistive load) 1 Form C rated 1.0A @ 30 VDC, 0.3A @ 110 VDC or 0.5A @ 125 VAC. Gold over clad silver - suitable for dry circuits.

Electrical Connections: 18" (46 cm) cable assembly with 8 conductors.

Optional lengths to 100' (30.5 m).

Power Requirements: 24 VDC, regulated ±10%.

Mounting Orientation: Diaphragm in vertical position. Consult factory for other position orientations.

Set Point Adjustment: Adjustable knobs on face.

Agency Approval: CE.

SWITCH SPECIFICATIONS 3000MRS

Switch Type: Each setpoint has a solid state relay.

Switching Voltage: 20-280 VAC (47 - 63 Hz).

Switching Current: 1.0 amp (AC) max., 0.01 mA (AC) min, (2) SPST N.O.

Electrical Connections: 18" (46 cm) cable assembly with 6 conductors, optional lengths to 100' (30.5 m).

Power Requirements: 24 VDC, regulated ±10%.

Mounting Orientation: Diaphragm in vertical position. Consult factory for other position orientations.

Set Point Adjustment: Adjustable knobs on face.

Agency Approval: CE.

OPTIONS — ACCESSORIES

Tamper-proof Knobs, require spanner type key (supplied) to change setpoints. Add suffix **-TAMP**

Low Temperature Option for use under 20°F (-6.7°C).

Add suffix **-LT**

Medium Pressure increases maximum rated pressure to 35 psig (2.41 bar). Add suffix **-MP**

High Pressure increases maximum rated pressure to 80 psig (5.5 bar). Add suffix **-HP**

A-298 Flat Aluminum Bracket, for flush mounting 3000MR/MRS

A-370 Mounting Bracket, flush mount 3000MR/MRS bracket. Bracket is then surface mounted. Steel with gray hammertone epoxy finish

A-600 R/C Snubber: Recommended for inductive loads like a solenoid or contactor.

Using solid state technology, the Series 3000MR and 3000MRS Photohelic® switch/gages combine the functions of a precise, highly repeatable differential pressure switch with a large easy-to-read analog pressure gage employing the durable, time-proven Magnehelic® gage design. Switch setting is easy to adjust with large external knobs on the gage face. Gage reading is unaffected by switch operation – will indicate accurately even if power is interrupted. Solid state design now results in greatly reduced size and weight. Units can be flush mounted in 4 1/16" (122 mm) hole or surface mounted with hardware supplied. 3000MR models employ versatile electromechanical relays with gold over silver contacts – ideal for dry circuits. For applications requiring high cycle rates, choose 3000MRS models with SPST (N.O.) solid state relays. All models provide both low and high limit control and include 18-inch (45 cm) cable assemblies for electrical connections.

The Photohelic® Switch/Gages have been utilized for years as Hi/Lo limit controls combined with a timer board to provide on-demand cleaning in dust filtration systems.

Standard Accessories

- | | |
|---------------------------------------|---|
| Mounting ring, snap ring | (4) 6-32 x 1 1/4" RH machine screws (panel mounting) |
| 18" (45 cm) cable assembly | (3) 6-32 x 5/16" RH machine screws (surface mounting) |
| (2) 3/16" tubing to 1/8" NPT adapters | |
| (2) 1/8" NPT pipe plugs | |

Model Number	Range, Inches W.C.	Minor Divs.	Model Number	Range, Kilopascals	Minor Divs.
3000(MR)(MRS)-00**	0-0.25	.005	3000(MR)(MRS)-1kPa	0-1.0	.02
3000(MR)(MRS)-0*	0-0.5	.01	3000(MR)(MRS)-3kPa	0-3.0	.10
3001(MR)(MRS)	0-1.0	.02	3000(MR)(MRS)-4kPa	0-4.0	.10
3002(MR)(MRS)	0-2.0	.05			
3003(MR)(MRS)	0-3.0	.10	Model Number	Range, MM W.C.	Minor Divs.
3005(MR)(MRS)	0-5.0	.10	3000(MR)(MRS)-6MM*	0-6	.20
3010(MR)(MRS)	0-10	.20	3000(MR)(MRS)-10MM	0-10	.50
3015(MR)(MRS)	0-15	.50	3000(MR)(MRS)-25MM	0-25	.50
3020(MR)(MRS)	0-20	.50	3000(MR)(MRS)-50MM	0-50	1.0
3030(MR)(MRS)	0-30	1.0	3000(MR)(MRS)-100MM	0-100	2.0
3050(MR)(MRS)	0-50	1.0			
3100(MR)(MRS)	0-100	2.0	Model Number	Range, CM W.C.	Minor Divs.
			3000(MR)(MRS)-20CM	0-20	.50
3000(MR)(MRS)-60Pa*	0-60	2.0			
3000(MR)(MRS)-125Pa	0-125	5.0			
3000(MR)(MRS)-250Pa	0-250	5.0			
3000(MR)(MRS)-500Pa	0-500	10.0			

* ±3% of full scale. ** ±4% of full scale.

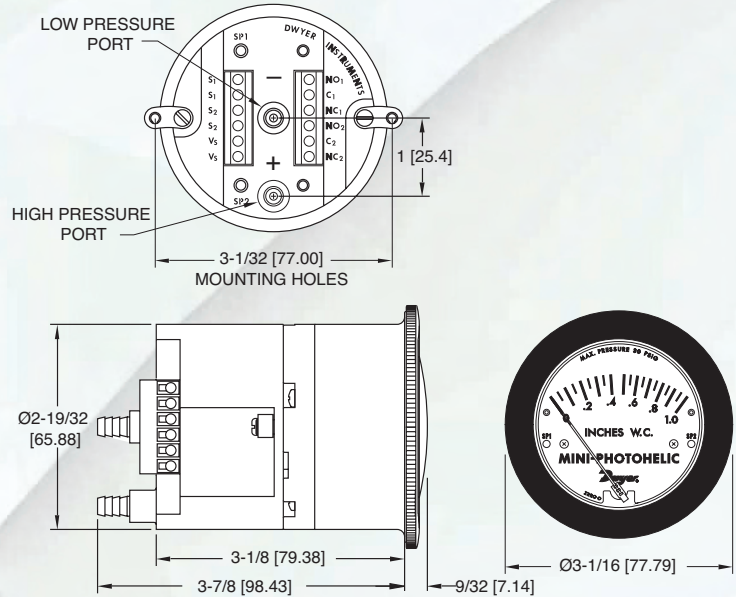

Pressure Switches

The Series MP Mini-Photohelic® differential pressure switch/gage combines the time proven Minihelic® II differential pressure gage with two SPDT switching setpoints. The Mini-Photohelic® gage is designed to measure and control positive, negative, or differential pressures consisting of non-combustible and non-corrosive gases. Gage reading is independent of switch operation. Switching status is visible by LED indicators located on the front and rear of the gage. Set points are adjusted with push buttons on back of unit. This extremely compact switch/gage is ideal for, dust collection and pneumatic conveying applications. As with the popular Photohelic® switch/gage, the Series MP switch gage is ideal for providing on-demand cleaning when used in conjunction with a timer board.

SPECIFICATIONS

GAGE SPECIFICATIONS

- Service:** Air and non-combustible, compatible gases.
- Wetted Materials:** Consult factory.
- Accuracy:** ±5% of full scale @ 70°F (21.1°C). Gage face mounted in vertical position.
- Pressure Limits:** 30 psig (2.067 bar).
- Temperature Limits:** 20 to 120°F (-6.7 to 49°C).
- Process Connections:** Barbed for 3/16" I.D. tubing (STD); 1/8" male NPT (optional).
- Size:** 4-1/8" (104.78 mm) depth x 3-1/16" (77.79 mm) diameter.
- Weight:** 23 oz (652 g).

SWITCH SPECIFICATIONS

- Switch Type:** (2) SPDT relays.
- Electrical Rating:** 5A @ 120/240 VAC Resistive; 5A @ 30 VDC.
- Electrical Connections:** Screw type terminal block. Accepts 22-12 AWG wire.
- Power Requirements:** 24 VDC / 24 VAC 50/60 Hz 4 watts.
- Mounting Orientation:** Gage face in vertical position.
- Set Point Adjustment:** Push Buttons.
- Standard Accessories:** (2) mounting screws, (1) .050" hex allen wrench.
- Agency Approvals:** UL, cUL, CE.

Model Number	Range, Inches of Water	Model Number	Range, MM of Water
MP-000	0-0.5	MP-25MM	0-25
MP-001	0-1.0	MP-50MM	0-50
MP-002	0-2.0	MP-100MM	0-100
MP-003	0-3.0		
MP-005	0-5.0		
MP-010	0-10		
MP-020	0-20		
MP-040	0-40		
MP-060	0-60		
MP-100	0-100		
		Model Number	Range, Pascals
		MP-125Pa	0-125
		MP-250Pa	0-250
		MP-500 Pa	0-500
Model Number	Range, PSI	Model Number	Range, kPa
MP-5PSI	0-5	MP-1KPa	0-1
MP-10PSI	0-10	MP-3KPa	0-3
MP-15PSI	0-15		

For optional 1/8" male NPT connections, add suffix -NPT to model numbers listed above. Example: MP-000-NPT. No extra charge. Allow additional lead time.

Series
DH3

Digihelic® Differential Pressure Controller



Digihelic® Controller in Photohelic® Gage, Square Root Output for Flow

Pressure Switches

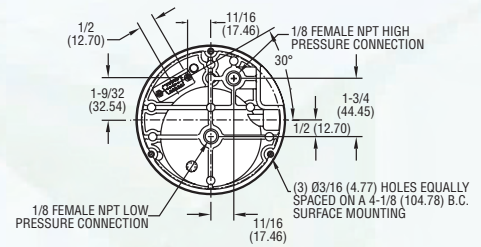
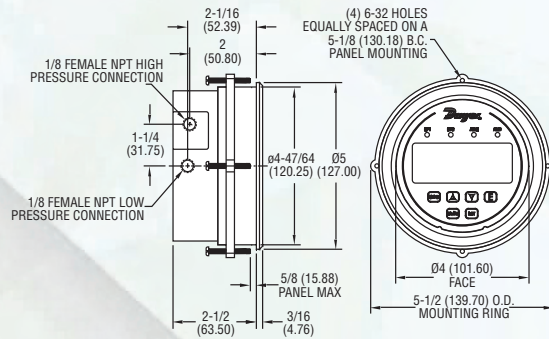

The Series DH3 Digihelic® Differential Pressure Controller is a 3 in 1 instrument possessing a digital display gage, control relay switches, and a transmitter with current output all packed in the popular Photohelic® gage style housing. Combining these 3 features allows the reduction of several instruments with one product, saving inventory, installation time and money. The Digihelic® controller is the ideal instrument for pressure, velocity and flow applications, achieving a 1% full scale accuracy on ranges down to the extremely low 0.25" w.c. to 2.5" w.c. full scale. Ranges of 5" w.c. and greater maintain 0.5% F.S. accuracy. Bi-directional ranges are also available.

The Series DH3 Digihelic® controller allows the selection of pressure, velocity or volumetric flow operation in several commonly used engineering units. 2 SPDT control relays with adjustable deadbands are provided along with a scalable 4-20 mA process output.

Programming is easy using the menu key to access 5 simplified menus which provide access to: security level; selection of pressure, velocity or flow operation; selection of engineering units; K-factor for use with flow sensors; rectangular or circular duct for inputting area in flow applications; set point control or set point and alarm operation; alarm operation as a high, low or high/low alarm; automatic or manual alarm reset; alarm delay; view peak and valley process reading; digital dampening for smoothing erratic process applications; scaling the 4-20 mA process output to fit your applications range and field calibration. See applications below for some popular uses.

APPLICATIONS

- Dust collection bag filters
- SCFM flow in ducts
- Filter status
- Static pressures in ducts or buildings
- Damper control
- Fan control

SPECIFICATIONS

Service: Air and non-combustible, compatible gases.

Wetted Materials: Consult factory.

Housing Material: Die cast aluminum case and bezel.

Accuracy: < 5" w.c. (except ±2.5" w.c.): ±1%; All other ranges: ±0.5% at 77°F (25°C) including hysteresis and repeatability (after 1 hour warm-up).

Stability: < ±1% per year.

Pressure Limits: Ranges ≤ 2.5" w.c.: 25 psi; ±2.5", 5" w.c.: 5 psi; 10" w.c.: 5 psi; 25" w.c.: 5 psi; 50" w.c.: 5 psi; 100" w.c.: 9 psi.

Temperature Limits: 32 to 140°F (0 to 60°C).

Compensated Temperature Limits: 32 to 140°F (0 to 60°C).

Thermal Effects: 0.020%/°F (0.036/°C) from 77°F (25°C).

Power Requirements: 12-24 VAC/VDC.

Power Consumption: 3 VA max.

Output Signal: 4-20 mA DC into 900 ohms max.

Zero & Span Adjustments: Accessible via menus.

Response Time: 250 ms (dampening set to 1).

Display: Backlit 4 digit LCD 0.4" height LED indicators for set point and alarm status.

Electrical Connections: 15 pin male high density D-Sub connection. 18" (46 cm) cable with 10 conductors included.

Process Connections: 1/8" female NPT. Side or back connections.

Enclosure Rating: Face designed to meet NEMA 4X (IP66).

Mounting Orientation: Mount unit in vertical plane.

Size: 5" (127 mm) O.D. x 3-1/8" (79.38 mm).

Weight: 1.75 lbs. (794 g).

Agency Approvals: CE.

SWITCH SPECIFICATIONS

Switch Type: 2 SPDT relays.

Electrical Rating: 1 amp @ 30 VAC/VDC.

Set Point Adjustment:

Adjustable via keypad on face.

Model	Ranges
DH3-002	0-0.25" w.c.
DH3-003	0-0.5" w.c.
DH3-004	0-1" w.c.
DH3-005	0-2.5" w.c.
DH3-006	0-5" w.c.
DH3-007	0-10" w.c.
DH3-009	0-25" w.c.
DH3-010	0-50" w.c.
DH3-011	0-100" w.c.
DH3-013	0.25-0-0.25" w.c.
DH3-014	0.5-0-0.5" w.c.
DH3-015	1-0-1" w.c.
DH3-016	2.5-0-2.5" w.c.
DH3-017	5-0-5" w.c.
DH3-018	10-0-10" w.c.

ACCESSORIES

A-298 Flat Aluminum Bracket, for flush mounting.

A-370 Mounting Bracket, flush mount bracket. Bracket is then surface mounted. Steel with gray hammertone epoxy finish.

Digihelic® II Differential Pressure Controller

NEMA 4 (IP66) Housing, Perfect for Mounting Outdoors on Dust Collectors

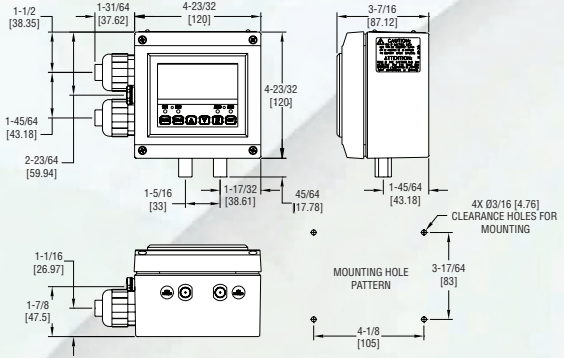

The Digihelic® Controller just got better with the New Series DHII Differential Pressure Controller. The DHII takes all the fabulous features of the standard Digihelic® Pressure Controller and packages them in a robust NEMA 4 (IP66) housing.

The Digihelic® II Pressure Controller combines the 2 SPDT control relays, 4-20 mA process output and Modbus® communications with a large, brightly backlit 4 digit LCD display that can easily be seen from long distances. The electrical wiring has also been enhanced in the DHII with its detachable terminal blocks. The removable terminals allow the installer to easily wire the terminal block outside the housing and then attach to the circuit board, reducing wiring difficulties and installation time in the process.

The Digihelic® II Differential Pressure Control in the new NEMA 4 (IP66) enclosure enables this product to be the perfect choice when mounting pressure controls outdoors. This housing also makes it the ideal solution for surface mounting directly to the dust collector.

ACCESSORIES

351-9, Mother Node™ silver RS-232 to RS-485 Converter with DB9F Connector. Includes 120 VAC to 12 VDC adapter

A-438, Surface Mounting Brackets

Digihelic® Links Communications Software

SPECIFICATIONS

Service: Air and non-combustible, compatible gases.

Wetted Materials: Consult factory.

Housing Material: Aluminum, glass.

Accuracy: ±0.5% at 77°F (25°C) including hysteresis and repeatability (after 1 hour warm-up).

Stability: < ±1% per year.

Pressure Limits: Ranges 5": 5 psi; 10": 5 psi; 25": 5 psi; 50": 5 psi; 100": 9 psi.

Temperature Limits: 32 to 140°F (0 to 60°C).

Compensated Temperature Limits: 32 to 140°F (0 to 60°C).

Thermal Effects: 0.020%/°F (0.036%/°C) from 77°F (25°C).

Power Requirements:

High Voltage Power = 100 to 240 VAC, 50 to 400 Hz or 132 to 240 VDC.

Low Voltage Power = 24 VDC ±20%.

Power Consumption:

Low Voltage Power = 24 VDC - 130 mA max.

High Voltage Power = 100 to 240 VAC, 132 to 240 VDC - 7VA max.

Output Signal: 4-20 mA DC into 900 ohms max.

Zero & Span Adjustments: Accessible via menus.

Response Time: 250 ms (dampening set to 1).

Display: 4 digit backlit LCD 0.6" height. LED indicators for set point and alarm status.

Electrical Connections: Euro type removeable terminal blocks with watertight conduit fittings for 1/2" watertight conduit.

Process Connections: 1/8 female NPT.

Enclosure Rating: Designed to meet NEMA 4 (IP66).

Mounting Orientation: Mount unit in horizontal plane.

Size: 4.73" x 4.73" x 3.43" (120 mm x 120 mm x 87.1 mm).

Weight: 2 lb 10 oz (1.19 kg).

Serial Communications: Modbus® RTU, RS485, 9600 Baud.

SWITCH SPECIFICATIONS

Switch Type: 2 SPDT relays.

Electrical Rating: 8 Amps at 240 VAC resistive.

Set Point Adjustment: Adjustable via keypad on face.

Modbus® is a registered trademark of Schniieder Automation.

Available Pressure Engineering Units												
Model No.	in. wc	ft. wc	mm wc	cm wc	psi	in. Hg	mm Hg	mbar	Pa	kPa	hPa	oz. in.
DHII-006	5.000	.4167	127.0	12.70	.1806	.3678	9.342	12.45	1245	1.245	12.45	2.890
DHII-007	10.00	.8333	254.0	25.40	.3613	.7356	18.68	24.91	2491	2.491	24.91	5.780
DHII-008	25.00	2.083	635.0	63.50	.9032	1.839	46.71	62.27	6227	6.227	62.27	14.45
DHII-009*	50.00	4.167	1270	127.0	1.806	3.678	93.42	124.5		12.45	124.5	28.90
DHII-010*	100.0	8.333	2540	254.0	3.613	7.356	186.8	249.1		24.91	249.1	57.80

Bi-Directional* Ranges also available: DHII-015 Range: 2.5 - 0 - 2.5" w.c.

DHII-016 Range: 5 - 0 - 5" w.c.

DHII-017 Range: 10 - 0 - 10" w.c.

*Velocity and volumetric flow not available on bi-directional range units and models DH-009 & DH-010.

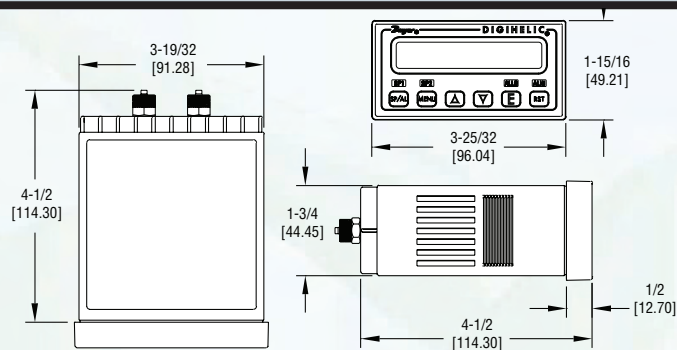

The Series DH Digihelic® Differential Pressure Controller is a 3-in-1 instrument possessing a digital display gage, control relay switches, and a transmitter with current output. Combining these three features allows the reduction of several instruments with one product, saving inventory, installation time and money. The Digihelic® controller is the ideal instrument for pressure, velocity and flow applications, achieving a 0.5% full scale accuracy on ranges from 5 to 100 in. w.c.

The Digihelic® controller allows the selection of pressure, velocity or volumetric flow operation in several commonly used engineering units. Two SPDT control relays with adjustable dead bands are provided along with a scalable 4-20mA process output. The Series DH provides extreme flexibility in power usage by allowing 120/220 VAC and also 24 VDC power which is often used in control panels.

Programming is easy using the menu key to access five simplified menus which provide access to: security level; selection of pressure, velocity or flow operation; selection of engineering units; K-factor for use with flow sensors; rectangular or circular duct for inputting area in flow applications; set point control or set point and alarm operation; alarm operation as a high, low or high/low alarm; automatic or manual alarm reset; alarm delay; view peak and valley process readings; digital dampening for smoothing erratic process applications; scaling the 4-20mA process output to fit your application's range; Modbus® communications; and field calibration.

With all this packed into one product it is easy to see why the Digihelic® controller is the only instrument you will need for all your pressure applications.

APPLICATIONS

- Dust Collection Bag Filters
- SCFM Flow In Ducts
- Filter Status
- Damper Control
- Fan Control

SPECIFICATIONS

Service: Air and non-combustible, compatible gases.

Wetted Materials: Consult factory.

Housing Material: ABS plastic, UL approved 94-V-0.

Accuracy: $\pm 0.5\%$ at 77°F (25°C) including hysteresis and repeatability.

Stability: $< \pm 1\%$ per year.

Pressure Limits: Ranges ≤ 2.5 in. w.c. = 2 psi
5": 5 psi; 10": 5 psi; 25": 5 psi; 50": 5 psi; 100": 9 psi.

Temperature Limits: 32 to 140°F (0 to 60°C).

Compensated Temperature Limits: 32 to 140°F (0 to 60°C).

Thermal Effects: 0.020%/°F (0.036/°C) from 77°F (25°C).

Power Requirements: High Voltage Power = 100 to 240 VAC, 50 to 400 Hz or 132 to 240 VDC.

Low Voltage Power = 24 VDC $\pm 20\%$.

Power Consumption:

Low Voltage Power = 24 VDC - 130 mA max.

High Voltage Power = 100 to 240 VAC, 132 to 240 VDC - 7VA max.

Output Signal: 4-20 mA DC into 900 ohms max.

Zero & Span Adjustments: Accessible via menus.

Response Time: 250 ms.

Display: 4 digit LCD 0.4" height.

LED indicators for set point and alarm status.

Electrical Connections: Screw terminals.

Process Connections: Compression fitting for use with 1/8" ID X 1/4" OD tubing (3.175 mm ID x 6.35 mm OD).

Enclosure Rating: Face designed to meet NEMA 4X (IP66).

Mounting Orientation: Mount unit in horizontal plane.

Size: 1/8 DIN.

Panel Cutout: 1.772 x 3.620 in (45 x 92 mm).

Weight: 14.4 oz. (408 g).

Serial Communications: Modbus® RTU, RS485, 9600 Baud.

Agency Approvals: CE, UL.

SWITCH SPECIFICATIONS

Switch Type: 2 SPDT relays.

Electrical Rating: 8 Amps at 240 VAC resistive.

Set Point Adjustment: Adjustable via keypad on face.

One Control for all your Pressure Applications

Reduces Instruments, Inventory, Installation Time and Cost

Compact 1/8 DIN housing reduces panel space.

Set Point Status LED Indicators display set point activation. Allows user to view process status from a distance.

"Hot Key" saves time by allowing instant access to set point and alarms. Set points/alarms can be easily adjusted with arrow keys.

Menu Key Scrolls through menus to adjust settings. 5 simple menus allow for quick set-up and reduced installation time.

Adjustable clip for panel mounting

Set point 2 or alarm output (SPDT). Selectable direct acting control relay with adjustable deadband or high, low or high low alarm.

4-20 mA process output. View process remotely or send signal to PLC. Alleviates purchase of a separate transmitter.

24 VDC power supply. Universal power supply eliminates options, inventory and ordering mistakes.



Selectable Engineering Units in Pressure, Velocity or Flow, programmed on one unit. Alleviates time consuming conversions and flow charts

Alarm LED Indicator shows alarm activation status. View alarm status from a distance.

Reset button for clearing an alarm when alarm is set for manual operation.

Enter a menu or store a value. From home display press to view full scale range.

120-240 VAC power supply. Reduce inventory and eliminate lead times with universal power supply.

Set point 1 output (SPDT). Direct or reverse acting control relay with adjustable deadband.

Durable compression fittings for 1/4" O.D. x 1/8" I.D. plastic tubing. Secures tubing in harsh applications where vibration & temperature fluctuations occur.

RS-485 serial communications View, record, and adjust control settings remotely from a computer with Modbus® protocol.

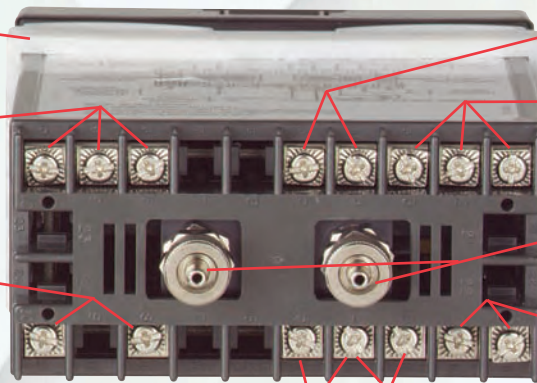

Remote reset switch for alarm. Acknowledge alarm from remote location. For users that need quick alarm reset from a distance.

Available Pressure Engineering Units

Model No.	in. wc	ft. wc	mm wc	cm wc	psi	in. Hg	mm Hg	mbar	Pa	kPa	hPa	oz. in.
DH-002	.2500		6.350	0.635			0.467	0.623	62.28			0.144
DH-004	1.000		25.40	2.540			1.868	2.491	249.1	0.249	2.491	0.578
DH-006	5.000	.4167	127.0	12.70	.1806	.3678	9.342	12.45	1245	1.245	12.45	2.890
DH-007	10.00	.8333	254.0	25.40	.3613	.7356	18.68	24.91	2491	2.491	24.91	5.780
DH-008	25.00	2.083	635.0	63.50	.9032	1.839	46.71	62.27	6227	6.227	62.27	14.45
DH-009*	50.00	4.167	1270	127.0	1.806	3.678	93.42	124.5		12.45	124.5	28.90
DH-010*	100.0	8.333	2540	254.0	3.613	7.356	186.8	249.1		24.91	249.1	57.80

Bi-Directional Ranges* also available: DH-012 Range: 0.25 - 0 - 0.25" w.c.

DH-014 Range: 1.0 - 0 - 1.0" w.c.

DH-015 Range: 2.5 - 0 - 2.5" w.c.

DH-016 Range: 5 - 0 - 5" w.c.

DH-017 Range: 10 - 0 - 10" w.c.

*Velocity and volumetric flow not available on bi-directional range units and models DH-009 & DH-010.

ACCESSORIES

The Mother Node™ converter is an easy solution for utilizing the Digihelic® Controller's RS-485 serial communication and connecting to virtually any PC.

351-9N, Mother Node™ silver RS-232 to RS-485 Converter with DB9F Connector.

351-9, Mother Node™ silver RS-232 to RS-485 Converter with DB9F Connector. Includes 120 VAC to 12 VDC adapter.

A-266, Digihelic® controller surface mounting bracket.

A-203, 1/8" I.D. x 1/4" O.D. PVC tubing.

Digihelic® Links Communication Software

Modbus® is a registered trademark of Schneider Automation.



Series
1900

Compact Low Differential Pressure Switches

For Monitoring Filters or Initiating Cleaning Cycles



Pressure Switches

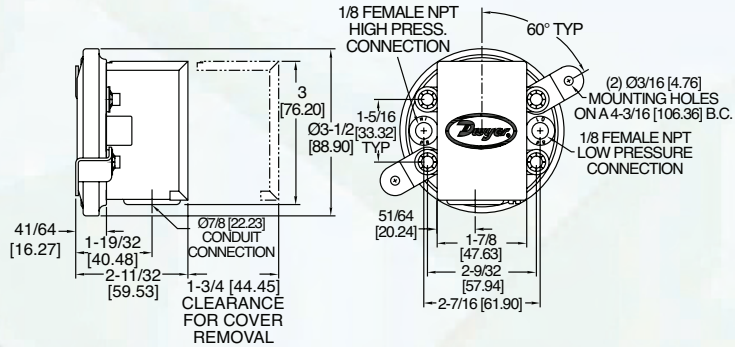
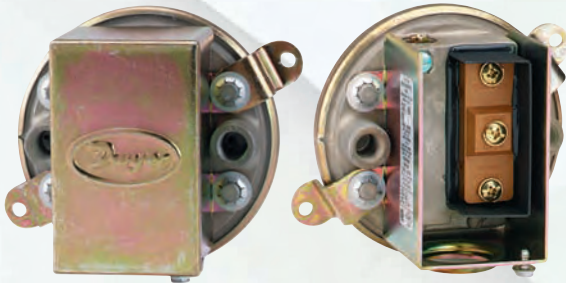

Series 1910 pressure switch. All pressure and electrical connections and set point adjustments are on one side for easy installation.

Series 1910 switch with conduit enclosure off. Shows electric switch and set point adjustment screw.

The Dwyer-engineered force-motion amplifier increases the leverage of diaphragm movement and results in a switch with excellent sensitivity and repeatability.

Our most popular series combines advanced design and precision construction to make these switches able to perform many of the tasks of larger, costlier units. For air and non-combustible compatible gases, Series 1900 switches have set points from 0.07 to 20" (1.8 to 508 mm) w.c. Set point adjustment is easy with range screw located inside conduit enclosure. Internal location helps prevent tampering. UL and CSA listed and FM approved. The 1900 is a compact, cost-effective solution for monitoring filter banks and providing a signal to initiate a cleaning cycle.

SPECIAL MODELS AND ACCESSORIES

MANUAL RESET MODEL 1900 MR includes special snap switch which latches on pressure increase above the setpoint. Switch must be manually reset after pressure drops below the setpoint. To order, change base model to 1900 and add MR suffix after range number. Example: 1900-10-MR. Available on -1, -5, -10 or -20 ranges only. Option is not UL, CSA or FM listed.

Note: Manual Reset (MR) Option for use only in single positive pressure applications.

A-399 Duct Pressure Monitor Kit — For use with standard or manual reset model switches. Includes mounting flange, tubing and adaptors

A-329 Street EII — Brass adapter for applications requiring right angle connections. Two required for differential pressures

SPECIFICATIONS

Service: Air and non-combustible, compatible gases.

Wetted Materials: Consult factory.

Temperature Limits: -30 to 180°F (-34 to 82.2°C).

Pressure Limits: 45" w.c.

(11.2 kPa) continuous, 10 psig (68.95 kPa) surge.

Switch Type: Single-pole double-throw (SPDT).

Repeatability: ±3%.

Electrical Rating: 15 A @ 120-480 VAC, 60 Hz. Resistive 1/8 HP @ 125 VAC, 1/4 HP @ 250 VAC, 60 Hz. Derate to 10 A for operation at high cycle rates.

Electrical Connections: 3 screw type, common, normally open and normally closed.

Process Connections: 1/8" female NPT.

Mounting Orientation: Diaphragm in vertical position. Consult factory for other position orientations.

Set Point Adjustment: Screw type inside conduit enclosure.

Weight: 1lb, 4.5 oz (581 g).

Agency Approvals: CE, UL, CSA, FM.

CAUTION: FOR USE ONLY WITH AIR OR COMPATIBLE GASES.

Explosion-Proof Cast Housing, Model 1911-CN. Explosion-proof housing, NEMA 7 & 9. Change base number to 1911 and add -CN suffix. Example: 1911-1-CN.



Weatherproof Housing

16 ga. steel enclosure with gasketed cover (NEMA 4, IP66) for wet or oily conditions. Withstands 200 hour salt spray test. Wt. 5 lbs. (2.3 kg). Switch must be factory installed. Change 1910 base number to 1911 and add -WP suffix. Example: 1911-1-WP.

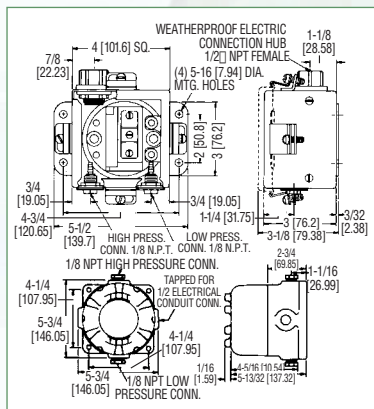

Explosion-Proof Housing

Cast iron base with brass cover. Rated Class I, Div. 1 & 2, Groups D; Class II, Div. 1 & 2, Groups E,F,G; Class III and NEMA 7, 9 NEMA 3. (7 lbs). Switch must be factory installed. Change model to 1911 and add -EXPL suffix. Example: 1911-1-EXPL.

SERIES 1910 SWITCHES OPERATING RANGES, DEADBANDS & PRICES

Model Number	Operating Range, Inches W.C.	Approximate Dead Band	
		At Min. Set Point	At Max. Set Point
1910-00	0.07 to 0.15	0.04	0.04
1910-0	0.15 to 0.55	0.10	0.10
1910-1	0.40 to 1.6	0.15	0.16
1910-5	1.40 to 5.5	0.30	0.30
1910-10	3.0 to 11.75	0.40	0.40
1910-20	4.0 to 20.0	0.40	0.50

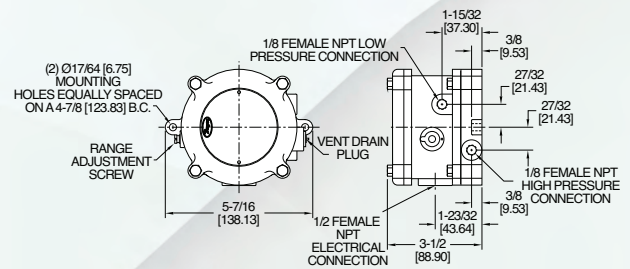

Model 1950 Explosion-Proof Differential Pressure Switch combines the best features of the popular Dwyer® Series 1900 pressure switch with an integral explosion-proof and weather-proof housing, making it an exceptional value for either application. It is CE, UL and CSA Listed, FM approved for use in Class I, Div. 1, Groups C and D, Class II Groups E, F, and G and Class III hazardous atmospheres (NEMA 7 & 9), Raintight (NEMA 3). Weatherproof features include a drain plug and O-ring seal in cover. Electrical connections are easily made by removing front cover. For convenience the set point adjustment screw is located on the outside of the housing. Twelve models offer set points from .03 to 20" w.c. (7.5 to 5 kPa) and from .5 to 50 psi (0.035 to 3.5 bar). The unit is very light and compact – about half the weight and bulk of other explosion-proof or weather-proof switches with separate enclosures. The 1950 is a compact solution for monitoring filtration units that are located outdoors or in hazardous locations in the plant.

SPECIFICATIONS

- Service:** Air and non-combustible, compatible gases.
- Wetted Materials:** Contact factory.
- Temperature Limits:** -40 to 140°F (-40 to 60°C); 0 to 140°F (-17.8 to 60°C) for 1950P-8, 15, 25, and 50. -30 to 130°F (-34.4 to 54.4°C) for 1950-02.
- Pressure Limits:**
 Continuous: 1950's - 45" w.c. (0.11 bar); 1950P's - 35 psi (2.41 bar); 1950P-50 only - 70 psi (4.83 bar).
 Surge: 1950's - 10 psi (0.69 bar), 1950P's - 50 psi (3.45 bar), 1950P-50 only - 90 psi (6.21 bar).
- Enclosure Rating:** IP64, NEMA 3, 7 and 9.
- Switch Type:** Single-pole double-throw (SPDT).
- Electrical Rating:** 15 A @, 125, 250, 480 VAC, 60 Hz. Resistive 1/8 HP @ 125 VAC, 1/4 HP @ 250 VAC, 60 Hz.
- Electrical Connections:** 3 screw type, common, normally open and normally closed.
- Process Connections:** 1/8" female NPT.
- Mounting Orientation:** Diaphragm in vertical position. Consult factory for other position orientations.
- Set Point Adjustment:** Screw type on top of housing.
- Weight:** 3.25 lb (1.5 kg); 1950-02 model, 4.4 lb (2 kg).
- Agency Approvals:** CE, UL, CSA, FM.

Model Number	Range, Inches W.C.	Approximate Dead Band at	
		Min. Set Point	Max. Set Point
1950-02-2S	.03 to .10	.025	.05
1950-00-2F	.07 to .15	.04	.05
1950-0-2F	.15 to .50	.10	.15
1950-1-2F	0.4 to 1.6	.15	.20
1950-5-2F	1.4 to 5.5	.30	.40
1950-10-2F	3 to 11	.40	.50
1950-20-2F	4 to 20	.40	.60

Model* Number	Range, PSID	Approximate Dead Band at	
		Min. Set Point	Max. Set Point
1950P-2-2F	0.5 to 2	.3	.3
1950P-8-2F	1.5 to 8	1.0	1.0
1950P-15-2F	3 to 15	.9	.9
1950P-25-2F	4 to 25	.7	.7
1950P-50-2F	15 to 50	1.0	1.5

CAUTION: For use only with air or compatible gases. Applications with hazardous atmospheres and a single positive pressure may require special venting. *P=PSID range models

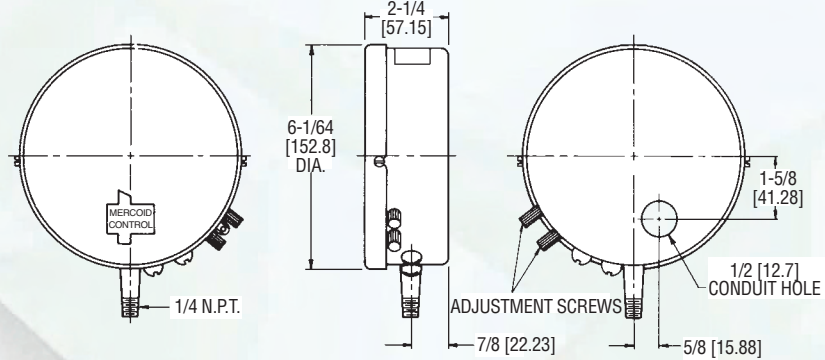
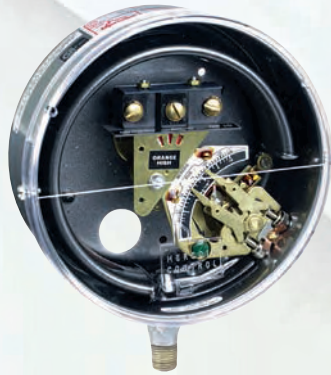

Pressure Switches

Customers tell us that this is the best pressure switch made. The Mercoid D Series is one of the world's broadest lines of pressure switches. Whatever your application might be, it is most probable it can be fully satisfied with a D Series pressure switch. The D Series has extremely high sensitivity and great repeatability. The DA Models are equipped with two external adjustments, one for setting high pressure operating point, the other for setting low pressure operating point. Deadband, the difference between high and low setpoints, is adjustable over the full scale. The DS Models are equipped with a single external adjustment for setting operating point only. The deadband is fixed at a factory setting and cannot be altered in the field. The Series D Pressure Switch provides a monitoring switch for vacuum or pressure air lines in pneumatic conveying systems.

FEATURES

- Visible calibrated dial.
- On/off indication.
- Adjustable or fixed deadband.
- SPDT snap-action switch.
- External switch setpoint adjustments.
- Minimum deadband is obtainable at any point in the range.
- UL listed, CSA approved.
- General purpose, weatherproof or explosion-proof enclosures.

Options

Weatherproof, explosion-proof, other circuit types, SS wetted materials, other ranges up to 8000 psig, manual reset, hermetically sealed switches.

SPECIFICATIONS

- Wetted Materials:** Brass. 403 SS or 316 SS available.
- Temperature Limit:** 180°F (82°C).
- Pressure Limit:** Maximum pressure of the operating range.
- Enclosure Rating:** General purpose. Weatherproof or explosion-proof available.
- Repeatability:** ± 1% of full operating range.
- Switch Type:** SPDT snap switch. Other circuit types available.
- Electrical Rating:** See model chart.
- Electrical Connections:** Screw terminal.
- Conduit Connection:** 1/2" hole for conduit hub.
- Process Connection:** 1/4" male NPT.
- Mounting Orientation:** Vertical.
- Set Point Adjustment:** Thumbscrew.
- Weight:** 4 lb (1.8 kg).
- Deadband:** See model chart.
- Agency Approvals:** UL, CSA, CE, FM. (Consult factory for FM approved models).

Bourdon Tube Material	Adjustable Operating Range psig (bar)	Adjustable Deadband SPDT: 15A @120/240 VAC		Fixed Deadband SPDT: 15A @ 120/240 AC	
		Minimum Deadband psig (bar)	Model Number	Fixed Deadband psig (bar)	Model Number
Brass	0-30" Hg Vac (0 - 762 mm Hg)	9" Hg	DA-7031-153-2	3" Hg	DS-7231-153-2
	1/8-20 (.009 - 1.39)	4 (.28)	DA-7031-153-3A	1.5 (.10)	DS-7231-153-3A
	1-35 (.07 - 2.41)	5 (.35)	DA-7031-153-4	1.5 (.10)	DS-7231-153-4
	2-60 (.14 - 4.14)	6 (.41)	DA-7031-153-5	2 (.14)	DS-7231-153-5
	5-100 (.35 - 6.9)	9 (.62)	DA-7031-153-6	2.5 (.17)	DS-7231-153-6

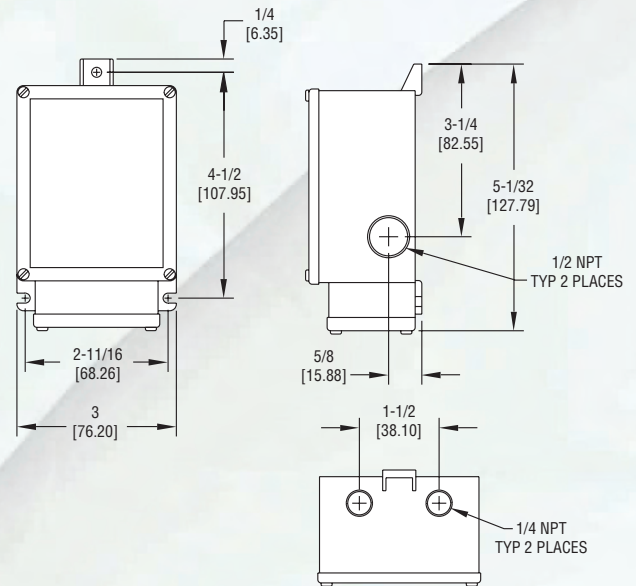

The Series 608 Differential Pressure Transmitters

convert positive, negative (vacuum), or differential pressures of clean, dry air or other non-conductive, non-corrosive gases into a standard two wire, 4-20 mA output signal. The use of an ultra thin silicon diaphragm enables precision measurement of differential pressures as low as 0.1" of w.c. while withstanding high static working pressures up to 100 psig (6.89 bar). The Series 608 transmitters are FM approved intrinsically safe for use in the specified hazardous locations when used with an approved intrinsic safety barrier. The rugged NEMA 4X, stainless steel housing combined with the intrinsic safe ratings makes this transmitter ideal for use in industrial and process plant environments where hazardous ratings are required.

APPLICATIONS

- Flow Measurements & Control
- Filter Monitoring

Model Number	Range (in. w.c.)	Model Number	Range (in. w.c.)
608-00	0-0.1	608-07	0-25.0
608-10*	0-0.1	608-17*	0-25.0
608-01	0-0.25	608-00B	0.1-0-0.1
608-11*	0-0.25	608-10B*	0.1-0-0.1
608-02	0-0.5	608-01B	0.25-0-0.25
608-12*	0-0.5	608-11B*	0.25-0-0.25
608-03	0-1.0	608-02B	0.5-0-0.5
608-13*	0-1.0	608-12B*	0.5-0-0.5
608-04	0-2.0	608-03B	1.0-0-1.0
608-14*	0-2.0	608-13B*	1.0-0-1.0
608-05	0-5.0	608-04B	2.0-0-2.0
608-15*	0-5.0	608-14B*	2.0-0-2.0
608-06	0-10.0	608-05B	5.0-0-5.0
608-16*	0-10.0	608-15B*	5.0-0-5.0

*Models have a ±0.25% F.S. accuracy.

SPECIFICATIONS

- Service:** Clean/dry air and compatible gases.
- Wetted Materials:** Consult factory.
- Accuracy:** ±0.5% or ±0.25% full scale.
- Stability:** ±0.5% F.S./year.
- Pressure Limits:** 100 psig (6.89 bar); 15 psid (1.03 bar).
- Temperature Limits:** -20 to 185°F (-28 to 85°C).
- Compensated Temperature Range:** 0 to 160°F (-18 to 71°C).
- Thermal Effect:** 0.5% Accuracy: ±0.02% F.S./°F; 0.25% Accuracy: ±0.01% F.S./°F.
- Power Requirements:** 12 to 36 VDC (2-wire).
- Output Signal:** 4-20 mA DC.
- Zero and Span Adjustments:** Potentiometers for zero and span.
- Response Time:** 250 ms.
- Loop Resistance:** DC: 0-1045 ohms maximum.
- Current Consumption:** 4-20 mA.
- Electrical Connections:** Screw terminal: Two 1/2" female NPT conduit.
- Process Connections:** Two 1/4" female NPT.
- Enclosure Rating:** NEMA 4X (IP65).
- Mounting Orientation:** Not position sensitive.
- Weight:** 2 lb (0.9 kg).
- Agency Approvals:** FM approved intrinsically safe for use in Class I, Div. 1, Groups A, B, C, D; Class II, Div. 1, Groups E, F, G; Class III, Div. 1 when wired with approved intrinsically safe barrier.
- Entity parameters: $V_{max}= 36$ VDC; $I_{max}= 250$ mA; $C_i=12$ nF; $L_i=0$ mH.

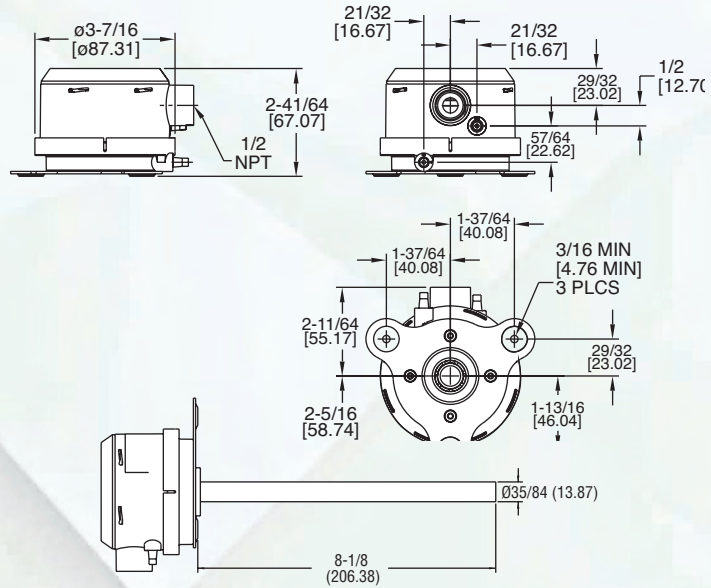

Pressure Transmitters

The Series MS Magnesense® Differential Pressure Transmitter is an extremely versatile transmitter for monitoring pressure and air velocity. This compact package is loaded with features such as: field selectable English or metric ranges, field upgradeable LCD display, adjustable dampening of output signal (with optional display) and the ability to select a square root output for use with Pitot tubes and other similar flow sensors.

Along with these features, the magnetic sensing technology provides exceptional long term performance and enables the Magnesense® to be the solution for a myriad of pressure and flow applications such as monitoring filters or duct air flow.

Model Number	Output	Selectable Ranges
MS-121	4-20 mA	0.1", 0.25", 0.5" (25, 50, 100 Pa)
MS-121-LCD	4-20 mA	0.1", 0.25", 0.5" (25, 50, 100 Pa)
MS-321	0-10 V	0.1", 0.25", 0.5" (25, 50, 100 Pa)
MS-321-LCD	0-10 V	0.1", 0.25", 0.5" (25, 50, 100 Pa)
MS-111	4-20 mA	1", 2", 5" (200, 500, 1000 Pa)
MS-111-LCD	4-20 mA	1", 2", 5" (200, 500, 1000 Pa)
MS-311	0-10 V	1", 2", 5" (200, 500, 1000 Pa)
MS-311-LCD	0-10 V	1", 2", 5" (200, 500, 1000 Pa)

ACCESSORY

A-435, Field Upgradeable LCD

SPECIFICATIONS

Service: Air and non-combustible, compatible gases.

Wetted Materials: Consult factory.

Accuracy: MS-X21: 0.5" w.c. & 0.25" w.c. ±1%, 0.1" w.c. ±2%. 100 Pa & 50 Pa ±1%, 25 Pa ±2%. MS-X11: 5" & 2" ±1%, 1" w.c. ±2%. 1000 & 500 Pa ±1%, 200 Pa ±2% (@ standard conditions).

Stability: ±1% F.S. / year.

Temperature Limits: 0 to 150°F (-18 to 66°C).

Pressure Limits: 1 psi maximum, operation; 10 psi, burst.

Power Requirements: 10 to 35 VDC (2-wire); 17 to 36 VDC or isolated 21.6 to 33 VAC (3-wire).

Output Signals: 4 to 20 mA (2-wire); 0 to 10 V (3-wire).

Response Time: Field adjustable 0.5 to 15 sec. time constant. Provides a 95% response time of 1.5 to 45 seconds.

Zero & Span Adjustments: Digital push button.

Loop Resistance: Current Output: 0-1250Ω max. Voltage Output: min. load resistance 1 k Ω.

Current Consumption: 40 mA max.

Display (optional): 4 digit LCD.

Electrical Connections:

4-20mA, 2-Wire: European Style Terminal Block for 16 to 26 AWG.

0-10V, 3-Wire: European Style Terminal Block 16 to 22 AWG.

Electrical Entry: 1/2" NPS Thread.

Accessory: Cable Gland for 5 to 10 mm diameter cable.

Process Connections: 3/16" (5 mm) ID tubing. Maximum OD 9 mm.

Enclosure Rating: NEMA 4X (IP66).

Mounting Orientation: Diaphragm in Vertical position.

Weight: 8.0 oz (230 g).

Agency Approvals: CE.

Magnesense® Differential Pressure Transmitter

Monitors Pressure or Air Velocity, Selectable Ranges

- **Field Upgradable LCD.** No need to order two separate transmitters. Simply stock a transmitter and display and you can satisfy any customer's requests. Simply remove cover and snap the LCD onto the board.

- **Field Selectable Ranges** in metric or English. Lowers stock and inventory requirements. You'll always have the right transmitter for every job.

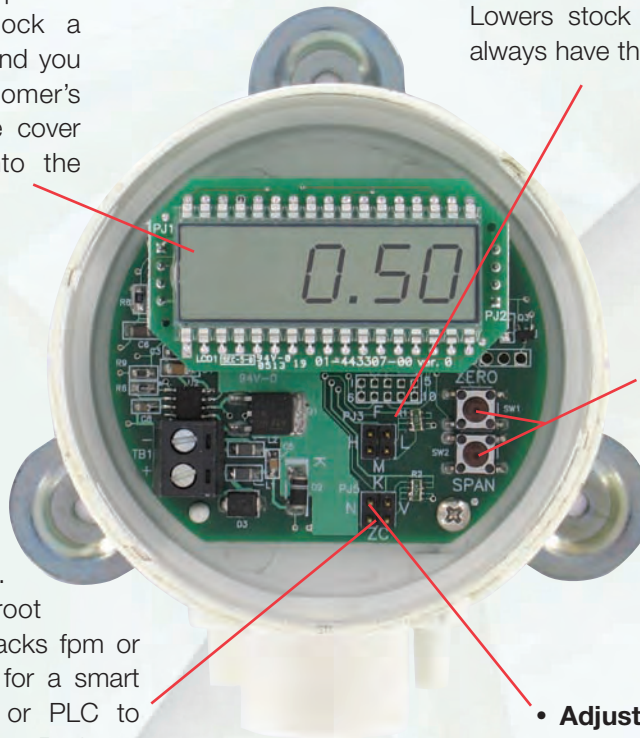

- **Digital Push Button Zero and Span.** Reduces calibration time significantly over other transmitters that utilize potentiometers. Lowers maintenance time and costs.

- **Field Selectable Air Velocity Mode** for fan and blower applications. Unit provides square root output that accurately tracks fpm or m/s flow rate. No need for a smart programmable indicator or PLC to convert pressure to air flow. Reduces components and installation time lowering overall costs.

- **Adjustable Digital Dampening** smooths out unstable pressure fluctuations common in air flow applications.

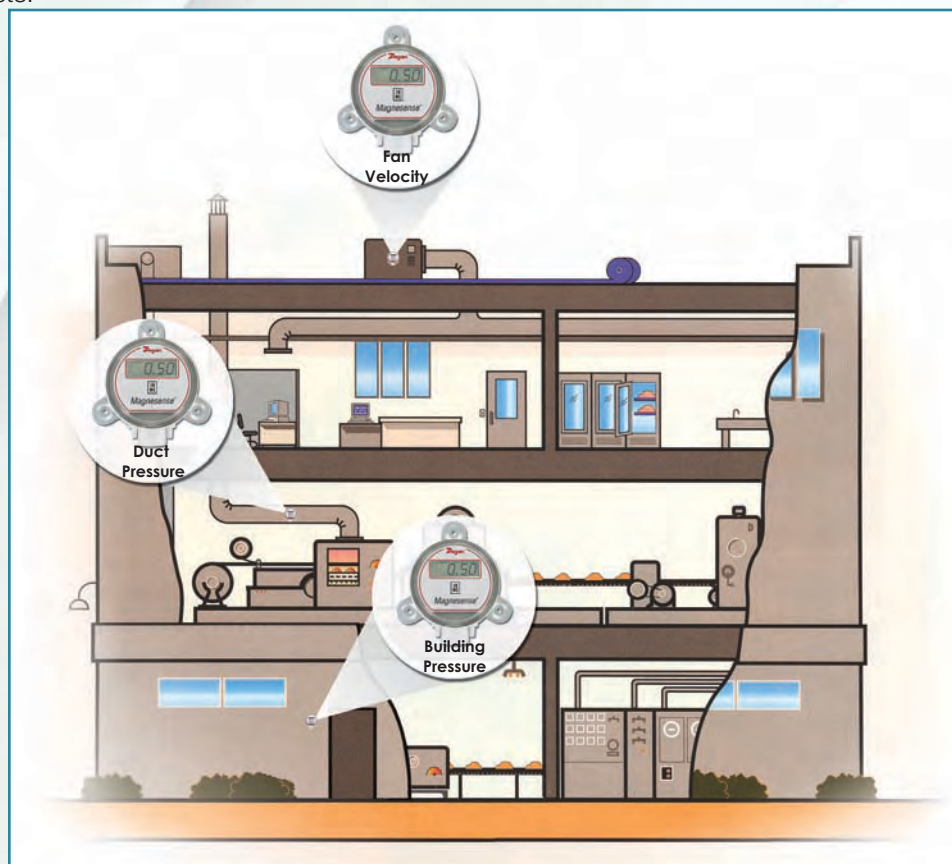

Series
6160T

One-Touch™ Differential Pressure Transmitter

One Button Calibration Reduces Installation and Calibration Time

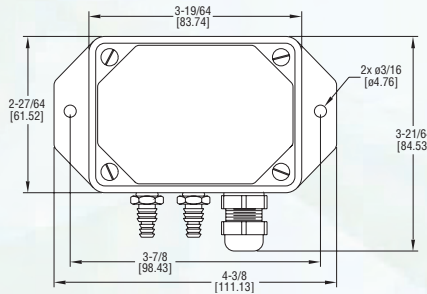

The Series 6160T One-Touch™ Differential Pressure Transmitter is designed for simplicity making it the ideal choice for installers and maintenance professionals. The Series 6160T One-Touch™ Differential Pressure Transmitter is a cost-effective, compact transmitter that reduces up front costs as well as expenses over the life of the product. The 6160T One-Touch™ Transmitter not only alleviates cumbersome turn pots typically found in most transmitters, but eliminates entirely the need to span the instrument during calibration. With a single digital push button, both ZERO AND SPAN are calibrated properly, nothing else is required. No additional reference pressure sources and separate calibration devices are necessary; no need to remove from service and send to the lab. All the installer or user needs to do is let the unit sit at zero reference pressure, and then push a button. That is it! The transmitter is now ready for operation. Time savings are enormous over the life of the product compared to traditional transmitters which require time to annually remove the product from service as well as the extensive time to actually perform a full span calibration. Mounting is simple with back mounting tabs that are inherent to the molded housing. Wiring the transmitter is quick and convenient with a removable terminal block that allows the installer to wire externally, then snap the wired block back onto the board inside the housing.

SPECIFICATIONS

Service: Air and non-combustible, compatible gases.
Wetted Materials: Consult factory.
Accuracy: ±1%.
Thermal Effect: ±0.05%/°F (±0.03%/°C).
Stability: ±1% F.S. / year.
Temperature Limits: 0 to 140°F (-18 to 60°C).
Pressure Limits: 1 psi maximum operation; 10 psi burst.
Power Requirements: 2-wire, 10 to 35 VDC.
Output Signal: 2-wire, 4 to 20 mA.
Response Time: 300 ms.
Pressure Calibration: One digital push button sets both zero & span simultaneously.

Loop Resistance: Current output: 1250 Ohm max.

Current Consumption: 40 mA max.
Electrical Connections: Removable European Style Terminal Block for 16 to 26 AWG.

Electrical Entry: Cable gland for 0.114 to 0.250" (2.9 to 6.4 mm) diameter cable.

Process Connections: Barbed, dual size to fit 1/8" (3 mm) and 3/16" (5 mm) I.D. rubber or vinyl tubing.

Enclosure Rating: NEMA 4X (IP65).
Weight: 4.0 oz (115 g).

Agency Approval: CE pending.

Series 6160T One-Touch™ Transmitter

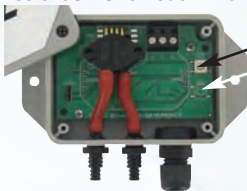

One Touch Button for quick setting of zero & span

Model Number	Ranges
6160T-10	10" w.c.
6160T-15	15" w.c.
6160T-20	20" w.c.
6160T-2 KPA	2 kPa
6160T-3 KPA	3 kPa
6160T-5 KPA	5 kPa

Series
616C

Differential Pressure Transmitter

Ranges from 0-1 in. w.c. to 0-100 psid, Accuracy ±0.25% or ±1% F.S.

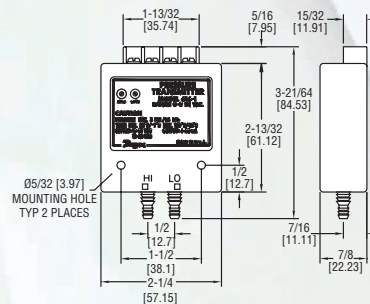

Series 616 Transmitters feature exceptional ±0.25% accuracy in several factory calibrated ranges. Choose the one just right for your application. Span and Zero controls included for fine tuning and minor re-calibration in the field. Compact housing allows unit to be mounted near filtration unit for convenient installation.

SPECIFICATIONS

Service: Air and non-combustible, compatible gases.
Wetted Materials: Consult factory.
Accuracy: 616: ±0.25% F.S.; 616C ±1% F.S.
Stability: ±1% F.S./yr.
Temperature Limits: 0 to 140°F (-17.8 to 60°C).
Compensated Temperature Limits: 20 to 120°F (-6.67 to 48.9°C).
Pressure Limits: See Chart.
Thermal Effect: ±0.02% F.S./°F (±0.0012% F.S./°C).
Power Requirements: 10-35 VDC (2-wire).

Output Signal: 4 to 20 mA.

Zero and Span Adjustments: Potentiometers for zero and span.

Loop Resistance: DC; 0-1250 ohms maximum.

Current Consumption: DC; 38 mA maximum.

Electrical Connections: Screw-type terminal block.

Process Connections: Barbed, dual size to fit 1/8" and 3/16" (3.12 mm and 4.76 mm) I.D. rubber or vinyl tubing.

Weight: 1.8 oz (51 g).

Agency Approvals: CE on 616 only.

Model No.	Range	Max. Press.	Model No.	Range	Max. Press.
616-00	0-1 in. w.c.	5 psig	616-8	0-10 psid	58 psig
616-0	0-2 in. w.c.	5 psig	616-9	0-20 psid	58 psig
616-1	0-3 in. w.c.	5 psig	616-10	0-30 psid	58 psig
616-2	0-6 in. w.c.	5 psig	616-11	0-50 psid	150 psig
616-3	0-10 in. w.c.	5 psig	616-12	0-100 psid	150 psig
616-4	0-20 in. w.c.	11 psig	616-3B	1.5-0-1.5 in. w.c.	5 psig
616-5	0-40 in. w.c.	11 psig	616-6B	3-0-3 in. w.c.	5 psig
616-6	0-100 in. w.c.	29 psig	616-10B	5-0-5 in. w.c.	5 psig
616-7	0-200 in. w.c.	29 psig	616-20B	10-0-10 in. w.c.	11 psig

Note: For 1% models add "C" after 616. 616C not available with 1" or 2" w.c. ranges.

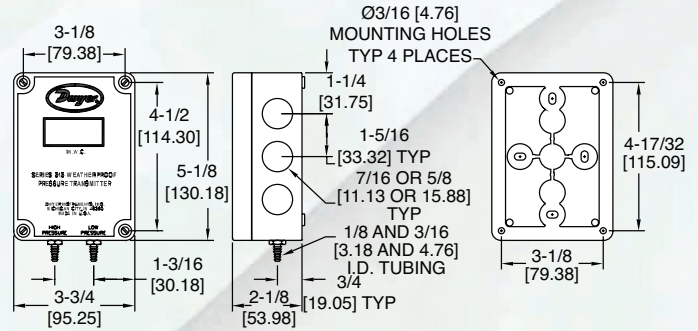
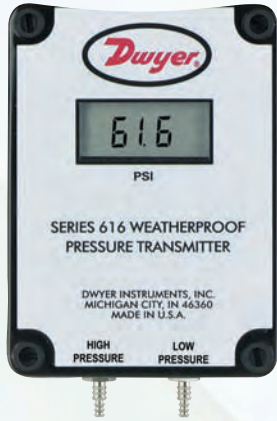

Positive, negative and differential pressures can be measured within a full span accuracy of $\pm 0.25\%$ with the Series 616W Differential Pressure Transmitter. Units are enclosed in a polycarbonate case, rated NEMA 4X (IP66) and operate by sensing the pressure of air and compatible gases then sending a standard 4-20 mA output signal.

Design enables operation in 2-wire current loops. A wide range of models are available factory calibrated to specific ranges. The span and zero controls are for use when checking calibration. They are not intended for re-ranging to a significantly different span. The LCD (as shown above) allows local indication of pressure. (If LCD is not needed, drop from model number).

The 616W transmitter's LCD display and NEMA 4X enclosure allows it to be mounted directly on to dust collectors located outdoors. It provides both local indication and signal back to the control network to communicate filtration status.

SPECIFICATIONS

Service: Air and non-combustible, compatible gases.

Wetted Materials: Consult factory.

Accuracy: $\pm 0.25\%$ F.S., display accuracy $\pm 0.5\%$.

Stability: $\pm 1\%$ F.S./yr.

Temperature Limits: 0 to 140°F (-17.8 to 60°C).

Compensated Temperature Limits: 20 to 120°F (-6.67 to 48.9°C).

Pressure Limits: See chart.

Thermal Effect: $\pm 0.02\%$ F.S./°F (0.0012% F.S./°C).

Power Requirements: 10-35 VDC (2-wire).

Output Signal: 4 to 20 mA.

Zero and Span Adjustments: Potentiometers for zero and span.

Loop Resistance: DC; 0-1250 ohms maximum.

Current Consumption: DC; 38 mA maximum.

Electrical Connections: Screw-type terminal block.

Process Connections: Barbed, dual size to fit 1/8" and 3/16" (3.12 and 4.76 mm) I.D. rubber or vinyl tubing.

Enclosure Rating: NEMA 4X (IP66).

Mounting Orientation: Vertical, consult factory for other position orientations.

Weight: Without LCD 8.8 oz. (249 g); with LCD 9.6 oz (272 g).

Agency Approvals: CE.

Model No.	Range	Max. Press.	Model No.	Range	Max. Press.	Model No.	Range	Max. Press.
616W-00-LCD	0-1 in.w.c.	10 in.w.c.	616W-7-LCD	0-20 in.w.c.	29 psig	616W-10B-LCD	5-0-5 in.w.c.	5 psig
616W-0-LCD	0-2 in.w.c.	10 in.w.c.	616W-8-LCD	0-10 psid	58 psig	616W-20B-LCD	10-0-10 in.w.c.	11 psig
616W-1-LCD	0-3 in.w.c.	10 in.w.c.	616W-9-LCD	0-20 psid	58 psig	616W-0M-LCD	0-500 Pa	10 in. w.c.
616W-2-LCD	0-6 in.w.c.	5 psig	616W-10-LCD	0-30 psid	58 psig	616W-1M-LCD	0-750 Pa	2.5 kPa
616W-3-LCD	0-10 in.w.c.	5 psig	616W-11-LCD	0-50 psid	150 psig	616W-2M-LCD	0-1.5 kPa	34.5 kPa
616W-4-LCD	0-20 in.w.c.	11 psig	616W-12-LCD	0-100 psid	150 psig	616W-3M-LCD	0-2.5 kPa	34.5 kPa
616W-5-LCD	0-40 in.w.c.	11 psig	616W-3B-LCD	1.5-0-1.5 in.w.c.	10 in.w.c.	616W-4M-LCD	0-5.0 kPa	75.8 kPa
616W-6-LCD	0-100 in.w.c.	29 psig	616W-6B-LCD	3-0-3 in.w.c.	5 psig	616W-5M-LCD	0-25.0 kPa	200 kPa

NOTE: Units with "M" in the model number are metric units.

Series
DM-2000

Differential Pressure Transmitter

Same Size as Standard Magnehelic® Differential Pressure Gage

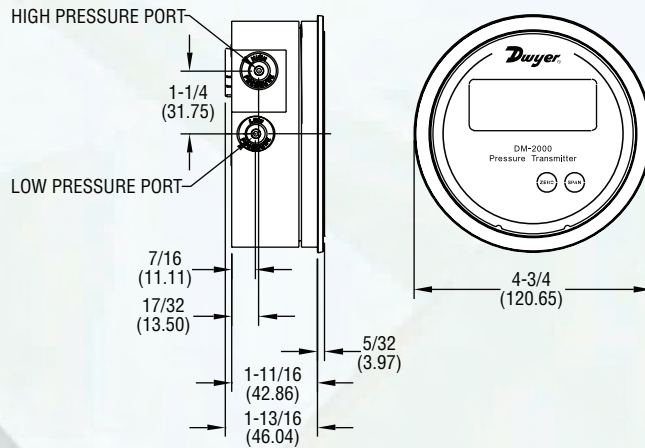

The Series DM-2000 Differential Pressure Transmitter senses the pressure of air and compatible gases and sends a standard 4-20 mA output signal. The DM-2000 housing is specifically designed to mount in the same diameter cutout as a standard Magnehelic® gage. A wide range of models are available factory calibrated to specific ranges.

Pressure connections are inherent to the glass filled plastic molded housing making installation quick and easy. Digital push-button zero and span simplify calibration over typical turn-potentiometers. An optional 3.5 digit LCD shows process and engineering units. The DM-2000 is ideal when digital indication of process or filter status is requested over standard analog gages.

APPLICATIONS

Differential Pressure across Filters.

SPECIFICATIONS

Service: Air and non-combustible, compatible gases.

Wetted Materials: Consult Factory.

Accuracy: ±1% F.S. at 70°F.

Stability: ±1% F.S./yr.

Temperature Limits: 20 to 120°F (-6.67 to 48.9°C).

Pressure Limits: 10 psig (0.69 bar).

Thermal Effect: ±0.055% F.S./°F (0.099% F.S./°C).

Power Requirements: 10-35 VDC (2 wire).

Output Signal: 4 to 20 mA.

Zero and Span Adjustments: Digital push-button zero and span.

Loop Resistance: DC: 0-1250 ohms maximum.

Current Consumption: DC: 38 mA maximum.

Electrical Connections: Screw-type terminal block.

Display: 3.5 digit LCD, 0.7" height.

Process Connections: 1/8" I.D. tubing.

Mounting Orientation: Vertical.

Weight: 4.8 oz (136 g).

Model Number	Range	Pa	mm wc	mBar	kPa	psi
DM-2001-LCD	.100 in wc	24.9	2.54	.249		
DM-2002-LCD	.250 in wc	62.2	6.35	.622		
DM-2003-LCD	.500 in wc	124.3	12.70	1.243	.124	
DM-2004-LCD	1.000 in wc	249	25.4	2.49	.249	
DM-2005-LCD	2.00 in wc	497	50.8	4.97	.497	
DM-2006-LCD	3.00 in wc	746	76.2	7.46	.746	.108
DM-2007-LCD	5.00 in wc	1243	127.0	12.43	1.243	.180
DM-2012-LCD	.250-0-.250 in wc	62.2-0-62.2	3.65-0-6.35	.622-0-.622		
DM-2013-LCD	.500-0-.500 in wc	124.3-0-124.3	12.70-0-12.70	1.243-0-1.243		

Note: Remove '-LCD' from the end of the model number if not needing the display.

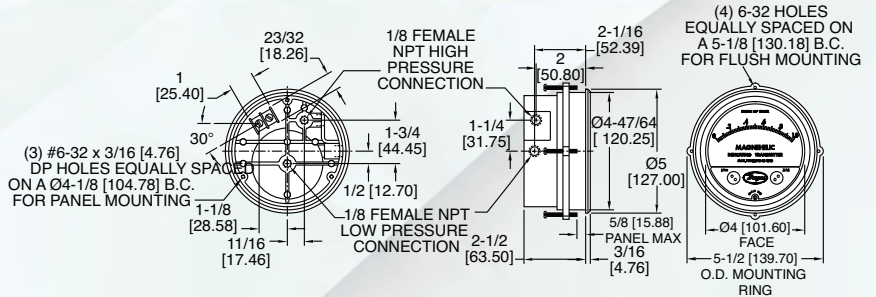

The Series 605 Magnehelic® Indicating Transmitter provides for both visual monitoring and electronic control of very low differential pressure. The Series 605 is ideal for control applications in systems where local indication is desired during routine maintenance checks or necessary when trouble shooting the system. The easily read dial gage is complimented by the two-wire, 4-20 mA control signal utilizing the time-proven Dwyer® Magnehelic® gage mechanical design and Series 600 transmitter technology. The two-wire design with terminal strip on the rear simplifies connection in any 4-20 mA control loop powered by a 10-35 VDC supply. The 605 provides both local indication of filter status as well as providing a signal back to the plant's control network.

ACCESSORIES

A-298 Flat Aluminum Bracket, for flush mounting
A-370 Mounting Bracket, flush mount Series 605 Transmitter in bracket. Bracket is then surface mounted. Steel with gray hammertone epoxy finish.

SPECIFICATIONS

GAGE SPECIFICATIONS

- Service:** Air and non-combustible, compatible gases.
- Wetted Materials:** Consult factory.
- Accuracy:** See chart.
- Stability:** ±1% F.S./yr.
- Pressure Limits:** See chart.
- Temperature Limits:** 20 to 120°F (-6.67 to 48.9°C).
- Process Connections:** 1/8" female NPT.
- Size:** 4" (101.6 mm) dial face, 5" (127 mm) O.D. x 2-11/16" (68.3 mm).
- Weight:** 1 lb, 12.6 oz (811 g).
- Agency Approvals:** CE.

TRANSMITTER SPECIFICATIONS

- Accuracy:** See chart (includes linearity, hysteresis, repeatability).
- Temperature Limits:** 20 to 120°F (-6.67 to 48.9°C).
- Compensated Temperature Range:** 32 to 120°F (0 to 48.9°C).
- Thermal Effect:** ±0.025% F.S./°F (0.045% F.S./°C).
- Power Requirements:** 10-35 VDC (2-wire).
- Output Signal:** 4 to 20 mA.
- Zero and Span Adjustments:** Protected potentiometers.
- Loop Resistance:** DC; 0-1250 ohms maximum.
- Current Consumption:** DC; 38 mA maximum.
- Electrical Connections:** Screw terminal block.
- Mounting Orientation:** Diaphragm in vertical position. Consult factory for other position orientations.

Model Number	Range in w.c.	Maximum Pressure	Electrical Accuracy +/-%	Mechanical Accuracy +/-%	Model Number	Range in w.c.	Maximum Pressure	Electrical Accuracy +/-%	Mechanical Accuracy +/-%
605-00N	.05-0-.20	25 psi (1.7 bar)	2	4	605-20	0-20.0	20 psi (1.4 bar)	0.5	2
605-11	.25-0-.25	25 psi (1.7 bar)	2	3	605-30	0-30	20 psi (1.4 bar)	0.5	2
605-0	0-.50	25 psi (1.7 bar)	2	3	605-50	0-50	20 psi (1.4 bar)	0.5	2
605-1	0-1.0	25 psi (1.7 bar)	2	2		Range in Pa			
605-2	0-2.0	2 psi (13.79 kPa)	0.5	2	605-60PA	0-60	25 psi (1.7 bar)	2	4
605-3	0-3.0	2 psi (13.79 kPa)	0.5	2	605-125PA	0-125	25 psi (1.7 bar)	2	3
605-6	0-6.0	2 psi (13.79 kPa)	0.5	2	605-250PA	0-250	25 psi (1.7 bar)	2	2
605-10	0-10	2 psi (13.79 kPa)	0.5	2	605-500PA	0-500	2 psi (13.79 kPa)	0.5	2

Output Signal Corresponds to System Vacuums or Pressures



Conduit Housing (-CH)



General Purpose Housing (-GH)

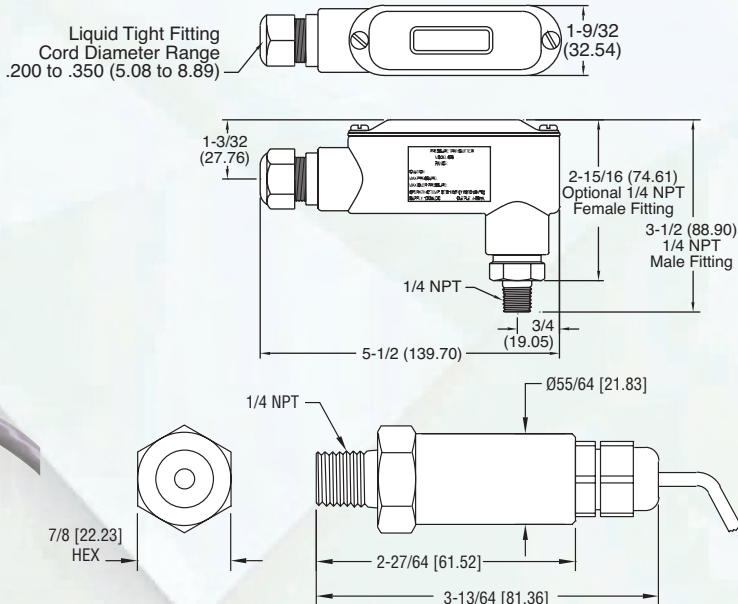

The Series 626 Pressure Transmitters possess a highly precise 0.25% piezo-resistive sensor contained in a compact, rugged, NEMA 4X stainless steel general purpose housing or cast aluminum conduit housing.

The Series 628 Pressure Transmitters are ideal for OEMs with 1% full scale accuracy sensors. The transmitter is also available in the general purpose stainless steel housing and the cast aluminum conduit housing.

The highly corrosive resistant 316L stainless steel wetted parts allow the Series 626 and 628 transmitters to measure the pressure in a multitude of processes. The Series 626 and 628 are available in ranges of vacuum, compound to 5000 psi with a variety of optional outputs, process connections and electrical terminations to allow you to select the right transmitter for your application. The 624/628 is perfect for monitoring pneumatic line vacuums and compressed air lines.

APPLICATIONS

- Vacuums in pneumatic conveying lines
- Positive pressures in compressed air headers

PRESSURE LIMITS

Range Number	Pressure Range (psig)	Maximum Pressure (psig)	Over Pressure (psig)	Range Number	Pressure Range (psig)	Maximum Pressure (psig)	Over Pressure (psig)
00	30" Hg-0	30	150	11	0-150	300	750
01	30-0-15	30	150	12	0-200	400	1000
02	30-0-30	60	300	13	0-300	600	1500
03	30-0-45	100	300	14	0-500	1000	2500
04	30-0-60	200	500	15	0-1000	2000	5000
05	30-0-100	200	500				
06	0-5	10	50				
07	0-15	30	150				
08	0-30	60	300				
09	0-50	100	300				
10	0-100	200	500				

SPECIFICATIONS

Service: Compatible gases and liquids.

Wetted Materials: Type 316 SS, 316L SS.

Accuracy: 626: 0.25% full scale. 628: 1% full scale (includes linearity, hysteresis, and repeatability).

Temperature Limit: 0 to 200°F (-18 to 93°C).

Compensated Temperature Range: 0 to 175°F (-18 to 79°C).

Thermal Effect: 626: ±0.02% FS/°F. 628: ±0.04% FS/°F (includes zero and span).

Pressure Limits: See table.

Power Requirements: 13 to 30 VDC.

Output Signal: 4 to 20 mA. Optional 0-5, 1-5, 0-10, 1-6 or 2-10.

Response Time: 50 msec.

Loop Resistance: 0 - 1300 ohms maximum for current. For voltage outputs, minimum load resistance: 2000 ohms.

Current Consumption: 38 mA (maximum).

Electrical Connections: Conduit Housing (-CH): terminal block, 1/2" female NPT conduit. General Purpose Housing (-GH): cable, DIN connector or M-12 4 Pin Connector.

Process Connection: 1/4" male or female NPT and BSPT.

Enclosure Rating: NEMA 4X (IP66).

Mounting Orientation: Mount in any position.

Weight: 10 oz (283 g).

Agency Approvals: CE.

Accuracy	626 628						0.25% Full Scale Accuracy 1.0% Full Scale Accuracy
Range		-00 -01 -02 -03 -04 -05 -06 -07 -08 -09 -10 -11 -12 -13 -14 -15					0-30" Hg Vacuum 30-0-15 psi 30-0-30 psi 30-0-45 psi 30-0-60 psi 30-0-100 psi 0-5 psi 0-15 psi 0-30 psi 0-50 psi 0-100 psi 0-150 psi 0-200 psi 0-300 psi 0-500 psi 0-1000 psi
Housing			-CH -GH				Conduit Housing General Purpose Housing
Process Connection				-P1 -P2 -P3 -P4 -P5			1/4" male NPT 1/4" female NPT 1/4" male BSPT 1/4" female BSPT Refrigerant Valve Depressor
Electrical Connection					-E1 -E2 -E3 -E4 -E5 -E6		Cable Gland with 3' of Prewired Cable Cable Gland with 6' of Prewired Cable Cable Gland with 9' of Prewired Cable DIN Connector Available with -GH Housing Only 1/2" female NPT Conduit Available with -CH Housing Only M-12 4 Pin Connector
Signal Output						-S1 -S2 -S3 -S4 -S5 -S6	4-20 mA 1-5 Volt 2-10 Volt 0-5 Volt 0-10 Volt 1-6 Volt
Options							-AT Aluminum Tag -NIST NIST Traceable Certificate -LED Bright Red LED display. Available with -CH housing only

626 with LED Display

Note: LED option is not NEMA 4X rated.



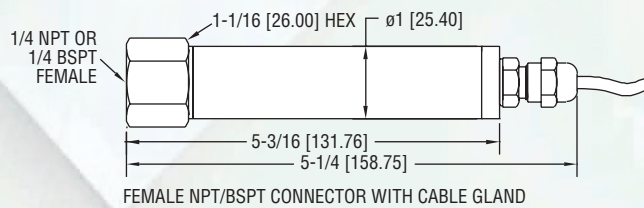
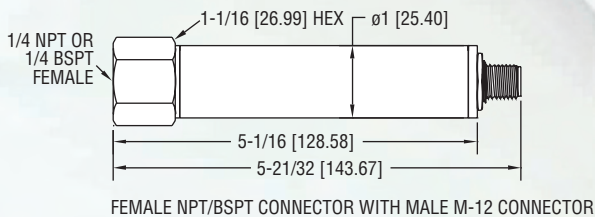
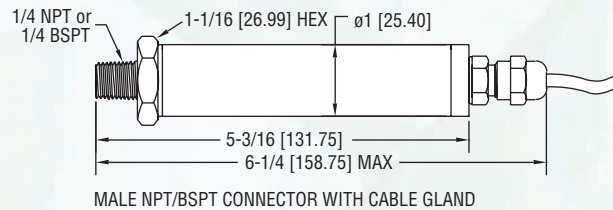
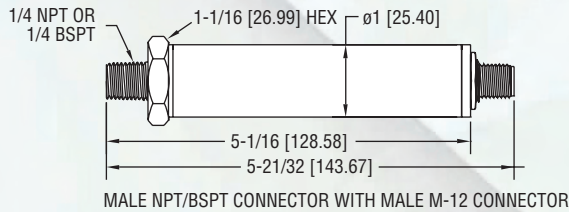
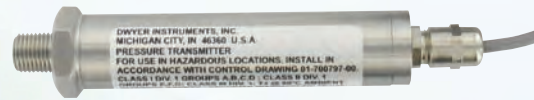
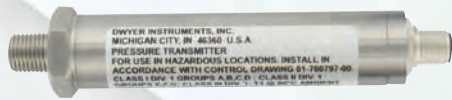

Ⓢ = CRITICAL DIMENSION
STANDARD TOLERANCES UNLESS NOTED:
ALL DECIMAL DIMENSIONS ± .005
ALL ANGLES ± 1°

The Series IS626 Intrinsically Safe Pressure Transmitters convert pressure into a standard 4-20 mA output signal. The Series IS626 can be used to accurately measure compatible gases and liquids compatible with its 316/316L Stainless Steel wetted parts. Series IS626 full scale accuracy is 0.25%. Designed for industrial environments with a NEMA 4X (IP66) housing, this transmitter resists most effects of shock and vibration. Models are available with a 3' cable or M-12 4 pin connection.

The IS626 is UL listed for use in Hazardous (Classified) Locations. The protection method is by Intrinsic Safety, "ia". It was investigated by UL under UL Standard 913 Sixth Edition and CSA Standard No. 157-92.

Applications: Monitoring pressure in hazardous environments.

Model	Range	Maximum Pressure (psig)	Over Pressure (psig)
IS626-00-GH-P1-E1-S1	30" Hg	30	150
IS626-07-GH-P1-E1-S1	15 psig	30	150
IS626-08-GH-P1-E1-S1	30 psig	60	300
IS626-09-GH-P1-E1-S1	50 psig	100	300
IS626-10-GH-P1-E1-S1	100 psig	200	500
IS626-11-GH-P1-E1-S1	150 psig	300	750
IS626-12-GH-P1-E1-S1	200 psig	400	1000
IS626-13-GH-P1-E1-S1	300 psig	600	1500
IS626-14-GH-P1-E1-S1	500 psig	1000	2500
IS626-15-GH-P1-E1-S1	1000 psig	2000	5000
IS626-16-GH-P1-E1-S1	1500 psig	3000	5000

Note: For optional M-12 4 pin electrical connection change E1 to E6.

ACCESSORIES

- A-295**, Female four pin M-12 to cable gland connector
- A-231**, 16' (5m) shielded cable with 4 pin female M-12 connection
- MTL5041**, intrinsically safe galvanic isolator
- MTL7706**, intrinsically safe zener barrier

SPECIFICATIONS

- Service:** Compatible gases and liquids.
- Wetted Materials:** Type 316, 316L SS.
- Accuracy:** 0.25% full scale (includes linearity, hysteresis, and repeatability).
- Temperature Limit:** 0 to 176°F (-18 to 80°C).
- Compensated Temperature Range:** 0 to 176°F (-18 to 80°C).
- Thermal Effect:** ±0.02% FS/°F (includes zero and span).
- Pressure Limits:** See Pressure Range Table.
- Power Requirements:** 10 to 28 VDC.
- Output Signal:** 4 to 20 mA.
- Response Time:** 50 msec.
- Loop Resistance:** 0 - 900 ohms maximum.
- Current Consumption:** 38 mA (maximum).
- Electrical Connections:** 3 ft. cable or 4-pin M-12 Connector.
- Process Connection:** 1/4" male or female NPT and BSPT.
- Enclosure Rating:** NEMA 4X (IP66).
- Mounting Orientation:** Mount in any position.
- Weight:** 8.9 oz (252 g).
- Agency Approvals:** CE, UL and cUL Intrinsically Safe to UL Standard 913.

For use in Hazardous (Classified) Locations:

- Class I Div. 1 Groups A,B,C,D
- Class II Div. 1 Groups E,F,G
- Class III Div. 1

Temperature Code: T4 @ 80°C ambient

Install in accordance with control drawing 01-700797-00.

WARNING To prevent ignition of flammable or combustible atmospheres, disconnect power before servicing.

Use with approved safety barriers using entity evaluation.

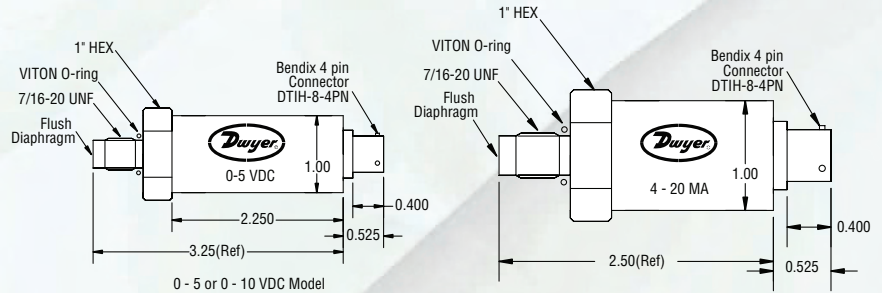

The **Series FDT Flush Diaphragm Transmitter** is designed for highly cyclical conditions. Flush sensor feature prevents any potential inaccuracies due to build-up or blockage which is a typical problem found in most non-flush transmitter sensors. Units have a non-oil filled sensor element that provides resistance to temperature fluctuations. Manufactured from a solid piece of steel, the sensing diaphragm can withstand the most abrasive/cyclical applications. Series FDT transmitters perform well in high cyclical environments with the presence of water-hammering or spiking.

Flush feature greatly reduces chance of leakage. Tough materials allow the unit to withstand harsh process conditions. Advanced manufacturing techniques, extreme environmental burn-in, and thorough residual stress relieving procedures ensure unit will maintain its high performance standard over time.

SPECIFICATIONS

Service: Compatible liquids and gases, adhesives, slurries, materials that can harden, or where a pressure cavity is not desired.

Wetted Materials: 316 & 15-5 SST.

Accuracy: $\pm 0.5\%$ FSO (includes non-linearity, hysteresis, and repeatability).

Stability: $\pm 0.25\%$ FSO per year.

Temperature Limits: -40 to 200°F (-40 to 93°C).

Compensated Temperature Limits: 0 to 170°F (-18 to 77°C).

Pressure Limit: 150% FS; Burst: 200% FS.

Thermal Effect: $\pm 1.5\%$ FSO over compensated range.

Power Requirements: 8-38 VDC.

Output Signal: FDT-A: 4-20 mA DC; FDT-V: 0-5 VDC.

Response Time: <1mS.

Loop Resistance: FDT-A: 0-1.5 ohms; FDT-V: 100 ohms.

Electrical Connections: 4 pin.

Process Connection: 7/16-20 UNF Male Flush Diaphragm. Optional 1/4" male NPT.

Enclosure Rating: NEMA 4X (IP66).

Mounting Orientation: Mount in any position.

Weight: 2 oz (57 g).

Agency Approval: CE.

ACCESSORY

Series FDT, A-168 mating connector for 4 pin M-12

Series	FDT			Series FDT Diaphragm Transmitter
Output		-A		4-20 mA
		-V		0-5 VDC
Range		-01		100 psi
		-02		150 psi
		-03		200 psi
		-04		300 psi
		-05		400 psi
		-06		500 psi
		-07		600 psi
		-08		700 psi
		-09		800 psi
		-10		900 psi
		-11		1,000 psi
		-12		2,000 psi
		-13		3,000 psi
		-14		4,000 psi
		-15		5,000 psi
		-16		6,000 psi
		-17		7,000 psi
	-18		8,000 psi	
	-19		9,000 psi	
	-20		10,000 psi	
Option		-NPT		1/4" male NPT
		-C08		0.25% FS accuracy



SIDE MOUNT

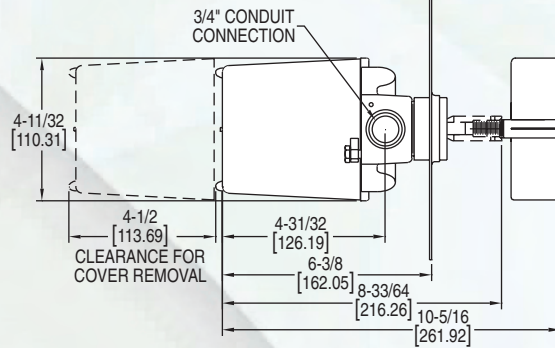

TOP MOUNT

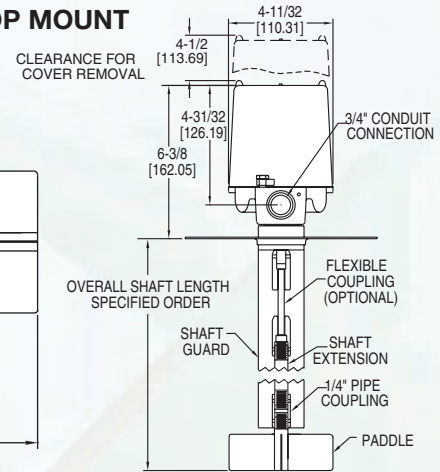

Incorporated in the design of the PLS is a magnetic drive that is time proven by decades of use in our Mark Series valve position indicator product line. A 1 rpm synchronous motor rotates the paddle utilizing a magnetic drive. As product builds up the paddle is impeded from moving and the resulting motor torque activates the output switches and stops the motor. A spring mechanism reactivates the motor and returns the switches to normal state when the product no longer impedes the paddle rotation.

Standard construction is weatherproof with explosion-proof optional, and the unit can be side or top mounted. A high temperature option is available for use with media up to 500°F (260°C). The PLS is designed with the industry standard 1-1/4" male NPT connection and mounting flanges. The PLS is perfect for level indication for receivers and silos in dilute phase pneumatic conveying systems.

FEATURES

- **Magnetic drive** that isolates and completely seals the control head from the process and environment preventing material or dust from entering the control head.
- **Motor shuts-off** when paddle stalls increasing motor life, preventing motor burnout, and decreasing power usage.
- **Slip clutch design** enabled by the magnetic drive that prevents damage to motor and drive mechanism from sudden or excessive loading on the paddle.
- **Status indication light** on weatherproof models. Light is on the side of the enclosure making it easy to view.
- **Screw cover** on the enclosure for easy access with no worries about losing bolts or screws.
- **Modular design** to allow field installation of any paddle, flanges, shaft extensions, or shaft guards.
- **Flexible coupling** available for protection of the paddle and drive from side loads, surges or impacts. Recommended for top mount applications with shaft extension and applications with large or heavy materials.

APPLICATIONS

Perfect for use in bins, hoppers, silos, tanks, feed lines, etc; and ideal for monitoring pneumatic conveying systems. Use to indicate full or empty level status for alarms, for level control by turning on and off conveyors, feeders, and elevators, or detect clogs and jams in conveying lines and elevators.

MOUNTING FLANGE

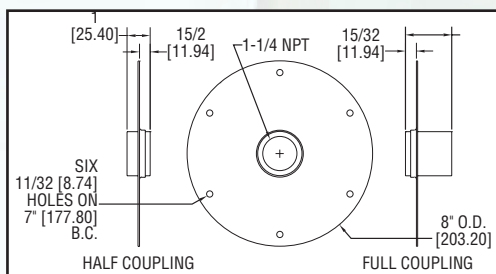

SPECIFICATIONS

Service: Dry powder or bulk materials compatible with wetted materials.

Sensitivity: Minimum material density of 5 lb/ft³ (80 kg/m³), maximum of 200 lb/ft³ (3200 kg/m³).

Wetted Materials:

Paddles: 316 SS. Exposed Shaft: 316 SS. Shaft Seal: PTFE.

Mounting Boss: Aluminum. Flexible Coupling: 316 SS.

Mounting Flanges: Carbon Steel or 316 SS.

Shaft Extension and Shaft Guards: Galvanized Steel or 316 SS

Temperature Limits:

Standard Construction: Process: -40 to 300°F (-40 to 148.9°C), Control Head: -40 to 200°F (-40 to 93.3°C).

High Temperature Option: Process: -40 to 500°F (-40 to 260°C), Control Head: -40 to 185°F (-40 to 85°C).

Time Delay Relay: Control Head: -25 to 140°F (-31.7 to 60.0°C)

Pressure Limit: 30 psig (2.07 bar) maximum for .5 micron or larger material.

Power Requirement: Select by part number: 110-120 VAC, 230 VAC, 24 VAC, 48 VAC, 12 VDC, or 24 VDC.

Power Consumption: Weatherproof models: 5 watts, Explosion-proof models: 3 watts.

Enclosure: Aluminum, powder coated.

Enclosure Rating: Weatherproof (W, WH construction): NEMA 4X, Explosion-proof (E, EH construction): NEMA 4X and rated for Class I, Div. 1 & 2, Groups C & D, Div. 1 & 2, Groups E, F, & G.

Switch Type: SPDT or optional DPDT snap switch.

Electrical Rating: 15A @ 120/230 VAC, 5A @ 24 VDC.

Electric Connections: Screw terminals.

Conduit Connection: 3/4" female NPT.

Process Connection: 1-1/4" male NPT. Optional flange.

Weight: Control head only: 4 lb (1.81 kg).

Indication Light: Red LED that activates when switch is made or when switch is not made with RL option (Not available on Explosion-proof models).

Options: Time delay relay, high temperature construction, top mount, shaft extensions, shaft shields, flexible couplings, other power voltages, reversed light.

Agency Approvals: UL approved as an auxiliary device or as an auxiliary device for hazardous locations.

PADDLES



PDL-1. 316 SS three vane paddle for light weight materials with a minimum bulk density of 5 lb/ft³ (80 kg/m³).



PDL-2. 316 SS three vane paddle for medium weight materials with minimum bulk density of 30 lb/ft³ (481 kg/m³).



PDL-3. 316 SS single vane paddle for medium weight materials with a minimum bulk density of 30 lb/ft³ (481 kg/m³). Fits through a 1-1/4" coupling eliminating the need for a mounting flange.



PDL-4. 316 SS single vane paddle for heavy weight materials with a minimum bulk density of 70 lb/ft³ (1122 kg/m³). Fits through 1-1/4" coupling eliminating the need for a mounting flange.

Example	PLS	W	S	1	1	SSF	SS	SS	024	FC	PLS-W-S-1-1-SSF-SS-SS-024-FC
Series	PLS										Paddle Level Switch
Construction		W E WH EH									Weatherproof Explosion-proof Weatherproof High Temperature Explosion-proof High Temperature
Switch			S D TD1 TD2								SPDT DPDT DPDT Time Delay – 120 VAC DPDT Time Delay – 230 VAC
Power Supply				1 2 3 4 5 6							110-120 VAC 230 VAC 24 VAC 48 VAC 12 VDC 24 VDC
Paddle					0 1 2 3 4						No paddle for Motor Control Only Style Low Density Paddle (PDL-1) Medium Density Paddle (PDL-2) Banana Paddle (PDL-3) High Density Paddle (PDL-4)
Flange						0 CSH CSF SSH SSF					No Mounting Flange Carbon Steel with Half Coupling (FLG-CSH) Carbon Steel with Full Coupling (FLG-CSF) 316 SS with Half Coupling (FLG-SSH) 316 SS with Full Coupling (FLG-SSF)
Shaft Extension Material							0 GS SS				None 1/4" NPS Galvanized Steel 1/4" NPS 316 SS
Protective Shield								0 GS SS			None 1-1/4" NPS Galvanized Steel 1-1/4" NPS 316 SS
Shaft Extension and Shield Length									XXX		Specify length in inches. Minimum 6, Maximum 48. May go longer on custom ordered product.
Options										RL FC	Reversed Light – light indication when paddle free rotating Flexible Coupling (CPL-FLX)

Level/Vibrators

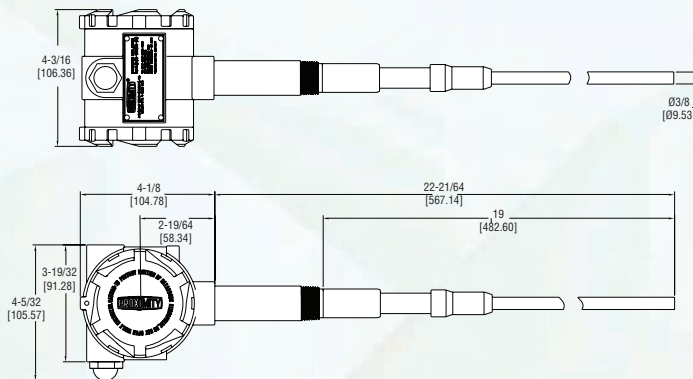

The CLS2 is a capacitive technology level switch that does not have any moving parts - no jams, no wear, nothing to break, and no maintenance. State of the art sensing technology in the CLS2, using impulse RF admittance measurement combined with an active guard, provides excellent level measurement and stability while being insensitive to material buildup. This technology also provides immunity to external RF sources like walkie-talkies and cell phones as well as minimal interference with radio communication or other electronic systems.

Capacitive level technology can be used for liquids, powders, and bulk materials and is great for difficult applications such as slurries, coating products, and liquids with solids. The CLS2 is ideal for level indication in silos, receivers, and transporters in pneumatic conveying systems. Wetted materials of PVDF and 316 SS assure great chemical compatibility and meet food grade requirements.

FEATURES

- **Automatic Calibration:** No need to turn calibration pots, just push the calibration button. The CLS2 even has an external magnet to activate the calibration without having to open the enclosure.
- **Universal Power Supply:** One model works from 12 to 240 VAC/DC without any jumpers or settings.
- **Coat Guard:** Unit is not affected by sticky, dusty, or clingy materials that coat or build up on the probe preventing false alarms.
- **Failsafe Setting:** Output switches can be set for Normally Open or Normally Closed condition on loss of power.
- **Status Indication:** Ultra high brightness external red LED switch status indicator, and internal indicators for power, sensor, and switch status that can be seen externally with window cap option.
- **Time Delay:** Prevent false alarms from material splashing, agitation, etc.
- **Removable Terminals:** Removable terminal block snaps in and out enabling easy wiring outside of the enclosure.

SPECIFICATIONS

Service: Liquids, powder, and bulk materials compatible with wetted materials.

Wetted Materials: 316 SS and Polyvinylidene fluoride (PVDF).

Temperature Limits: Ambient: -40 to 185°F (-40 to 85°C), -4 to 185°F (-20 to 85°C) with under 24 VAC/DC power supply. Process: -40 to 250°F (-40 to 121°C).

Pressure Limit: 365 psi (25 bar).

Enclosure Rating: Weatherproof, NEMA 4X (contact factory for explosion-proof option).

Switch Type: DPDT (two form C).

Electrical Rating: 8A @ 120/240 VAC res., 30 VDC. 1/2 hp @ 120 VAC and 1/4 hp @ 240 VAC ind.

Power Requirements: 12 to 240 VAC/DC; 24 to 240 VAC/DC.

Power Consumption: 2.8 Watts max.

Electrical Connection: 1/2" NPT conduit opening, screw termination with removable terminal block.

Process Connection: See model chart.

Mounting Orientation: Vertical or horizontal.

Set Point Adjustment: Trips when product touches probe. Cut or extend probe to length of desired trip point. Can be cut as short as 1" and can be extended by welding on to probe. (Minimum length will be effected by material being sensed.)

Response Time: 0.2 seconds.

Time Delay: Adjustable, 0 to 60 seconds.

Spark/Static Protection: 10 MEG Ohm dissipation resistance with spark gap. Surge current to 100A max.

Sensitivity: 8 Selectable settings, 1, 2, 4, 6, 8, 10, 14, 20 pF (at 30 pF nominal free capacitance).

Calibrate Switch — Pressing this switch twice initiates the automatic calibration process.

Time Delay Potentiometer — This control selects a delay time from 0 to 60 seconds from the detection of a level change to the output.

Dip Switch — This four section switch selects the sensitivity level and failsafe mode.

Sensor LED — Yellow. This LED is illuminated immediately when the probe capacitance exceeds the setpoint threshold.

Output LED — Red. This LED is illuminated when the relay is powered. It is affected by the failsafe setting and the delay.

Power LED — Green. This LED is illuminated when the unit is powered and indicates that power is being supplied to the sensing circuitry.

External LED — Red. The external LED indicator operates in conjunction with the internal Output LED.

External Calibration Magnet — An external magnet is provided on the end of a chain to initiate calibration without having to open the case. Calibration is started by touching the magnet to the label target twice.

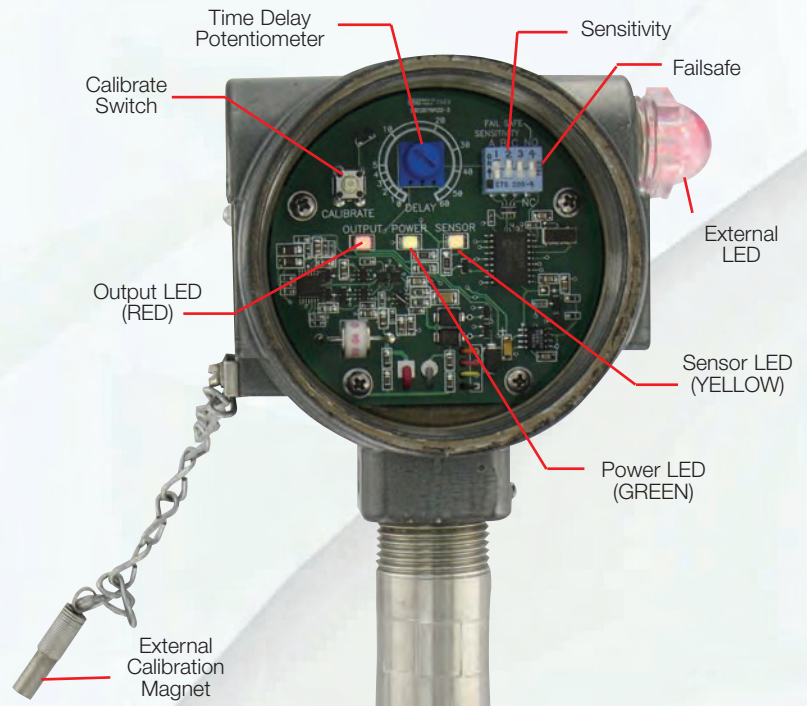

Example	CLS2	W	1	1	R	K	1	019	MC	CLS2-W11RK1-019-MC
Series	CLS2									Capacitive Level Switch
Enclosure		W								Weatherproof
Switch			1							DPDT rated 8A @ 12/240 VAC, 30 VDC res.
Power				1						12-240 VAC/DC
Supply Probe Type					R T C					Standard Rod: 316 SS, .375" diameter Threaded Rod: 316 SS (can attach field extensions) Cable: 316 SS with weight
Insulator Material						K				PVDF
Process Connection							1 2 3 4 5 6 8 9			3/4" male NPT 1" male NPT 1-1/2" male NPT 3/4" BSPT 1" BSPT 1-1/2" BSPT 1-1/2" sanitary clamp 2" sanitary clamp
Probe Length								XXX		Insertion length in inches. Example 019 is 19" length. (Minimum length is 6", with 3/4" sensing tip)
Options									M20 WC	M20 conduit connection with cable gland Window Cap

Explosion-Proof Ultra-Mag™ Level Switches

For Powder & Bulk Solids

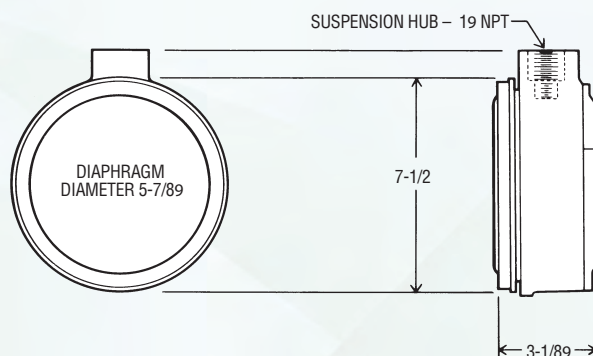
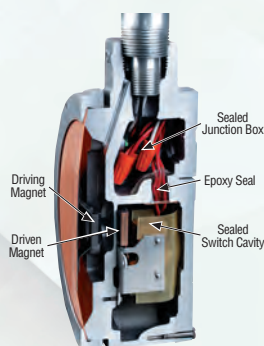

Suspension mounting

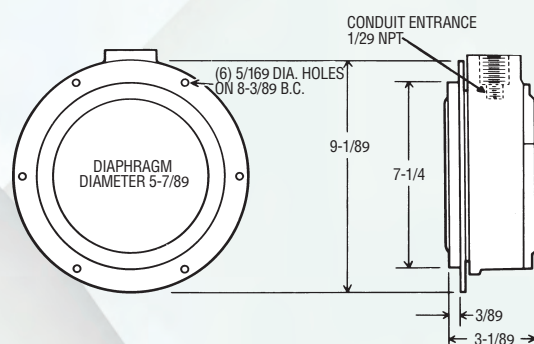

Flange mounting

A unique **Magnetic Linkage** isolates the electrical compartment from controlled product, reducing maintenance and improving sensitivity. The sealed switch compartment and sealed leads yield the utmost in reliable operation. A wide selection of diaphragms and switches are available with choices of flange or suspension mounting to fit your specific application. The Series Ultra-Mag™ is ideal for level indication of difficult bulk material applications that would damage paddle or capacitive switches. The magnetic linkage makes this simple explosion-proof diaphragm switch the most rugged and reliable level control for a variety of products (see cut-away above).

Mounting Selection: A choice of either suspension or flange mounting is available to match your application. Flange mounting is the best choice for control of low or intermediate level in vessels containing granular product that does not “bridge”, “rathole”, or otherwise build up on vessel walls. Choose suspension mounting for high level in vessels and for better operation with “bridging” product. See following two pages for more information on suspension and flange mounting kits. Note that the mounting configuration is represented by the letter “S” for suspension or “F” for flange which is the second digit in the part number on page 56.

Diaphragm Selection: A wide variety of diaphragms are available to match product bulk density, flowability, abrasiveness and temperature requirements while providing maximum sensitivity. The best choice for vessels subject to pressure or vacuum is “breathable” fabric (**P Series**), requiring no venting. Non-porous elastomer (**G Series**) type diaphragms are the best choice for more abrasive product and broader temperature range applications. Venting is always required with the G series and if used in pressurized vessels, venting to the tank atmosphere is required to allow pressure equalization. A slide rule “Diaphragm Selector” is available from the factory to help you choose the diaphragm best suited to your application.

SPECIFICATIONS

Service: Compatible powder or bulk solids.

Wetted Materials:

Mounting Flange: See model chart on page 56. Aluminum or 304 SS.

Diaphragm: See model chart on page 56. Urethane, Buna-N, PTFE, Silicone Rubber, Polyester, Fluoroelastomer, White Buna-N (food grade), or EPDM.

Temperature Limits: Depends on diaphragm material, see model chart on page 56. Standard switch: -40 to 185°F (-40 to 85°C), High temperature switch: -40 to 350°F (-40 to 176°C).

Pressure Limit: 60 psig (4.14 bar).

Enclosure Rating: General purpose or weatherproof and explosion-proof. See model chart on page 56.

Switch Type: See model chart on page 56.

Electrical Rating: See model chart on page 56.

Electrical Connections: 18 gage solid core, 600 volt TEW 105°C, style 1015. Epoxy sealed at conduit entrance. 12” (304.8 mm) long.

Conduit Connection: 1/2” female NPT.

Process Connection: For flanged models standard is 8-3/8” (212.725 mm) diameter bolt hole circle.

Mounting Orientation: Flange mount or suspend depending on model.

Set Point Adjustment: Internal screw.

Weight: 7 lb (3.18 kg).

Options: Suspension kits and flange adaptor rings.

Agency Approvals: UL and CSA.

Explosion-Proof Ultra-Mag™ Level Switches

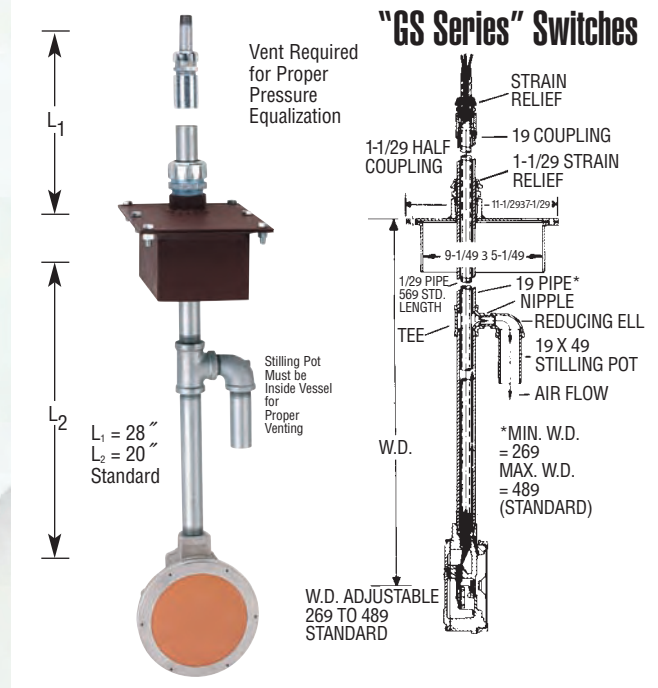
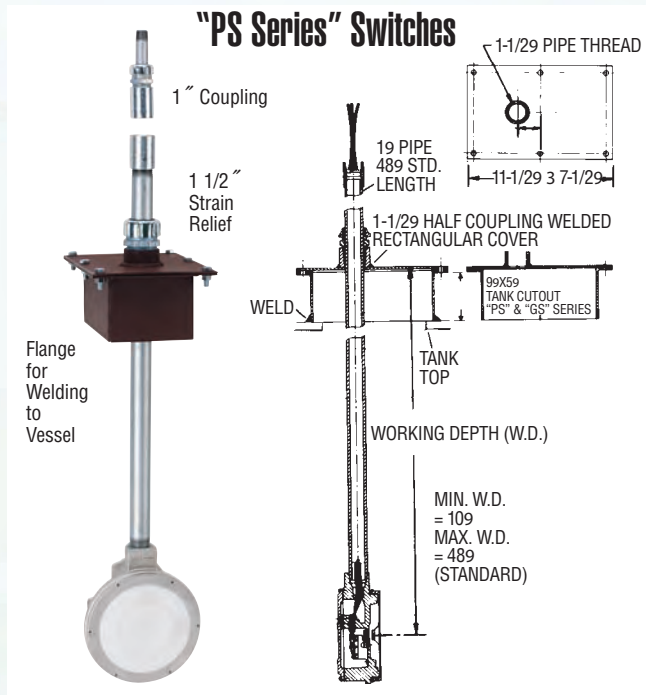

Note: Suspension assemblies sold separately.

Suspension Mounting is normally used for high level monitoring in vessels. For product over 20 pounds/cu. ft., the level switch (diaphragm face) should be located about 1/3 of the distance from the vessel wall to the point of entry of the product. For product less than 20 pounds/cu. ft., the unit should be located closer to the point of entry of the product, about 1/2 the distance from the vessel wall to the point of entry. Pressure required to depress the diaphragm and trip the switch is in the range of 5 - 15 oz. in the horizontal direction (perpendicular to the diaphragm). Suspension mounting provides the easiest vertical adjustment capability, greatest sensitivity and best maintenance conditions.

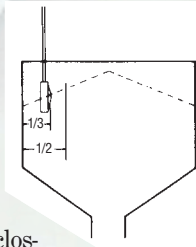

Suspension Assembly Kits: Pre-assembled kits are available from the factory, or you can build your own kits using standard pipe fittings. Pipes and fittings are normally galvanized steel, but aluminum and stainless steel pipes and fittings are available. Units pictured above are secured to a steel coverplate that rests on a rectangular steel flange welded into the top of the vessel. Aluminum and stainless steel coverplates and flanges are also available. Standard 48" long X 1" pipe provides working depth (WD) up to 48". Longer pipe (to provide greater WD) is available. GS Series switches have upper ($L_1 = 28"$ standard) and lower ($L_2 = 20"$ standard) 1" pipes, with a tee (for stilling pot) in between. A stilling pot is required to equalize pressure and keep dirt from building up behind the diaphragm. PS series require a 1/2" conduit in 1" suspension pipe for explosion proof applications. The 1/2" conduit (56" standard length) is a standard part of the GS Series assembly.

Product	Suggested Diaphragm*	Product	Suggested Diaphragm*
Abrasive.....	3D	Polypropylene Powder.....	7A
Aggregate.....	3D	Polypropylene Resin.....	17
Alumina.....	3D	Polystyrene Beads.....	3D
Ash, Dry.....	3D	Pot Ash.....	3D
Baking Powder.....	7B	Powdered Metal.....	3D
Baking Soda.....	7B	Powdered Ore.....	3D
Barite.....	3D	PVC Powder.....	7A
Bark, Ground.....	6G	PVC Resin.....	17
Barley, Ground or Meal.....	17	Rice.....	17
Barley, Whole.....	4B	Rye.....	3D
Beans, Edible.....	4B	Salt.....	3D
Bentonite.....	3D	Sand, Dry.....	3D
Bond, Foundry.....	17	Sand, Dry Silica.....	3D
Carbon, Black.....	7A	Sand, Foundry Prepared.....	5A
Cement, Klinker.....	8A	Sand, Shake Out.....	3D
Cement, Portland.....	4B	Sawdust, Dry.....	6G
Chips, Hogged Fuel.....	6G	Sea Coal.....	3D
Coal.....	3D	Sesame Seed.....	3D
Compost.....	5A	Shale, Crushed.....	3D
Core Sand, Foundry.....	3D	Silica, Flour.....	3D
Corn, Shelled.....	8A	Sludge, Sewage, Dried.....	1A
Diatomaceous Earth.....	7A	Sludge, Sewage, Ground.....	1A
Drill Mud.....	3D	Soda Ash.....	3D
Flour.....	7B	Soybeans, Cracked.....	3D
Fly Ash.....	3D	Soybean, Flake.....	7A
Glass Batch.....	3D	Soybean, Flour.....	7A
Gravel.....	3D	Soybean Meal.....	3D
Iron Ore, Crushed.....	3D	Soybean, Whole.....	3D
Kaolin Clay.....	3D	Sugar Beets, Whole.....	6H
Lime, Hydrated.....	5A	Sugar, Refined.....	7B
Lime, Stone.....	3D	Sunflower Seed.....	7A
Oats.....	4B	Taconite Pellets.....	3D
Peanuts in Shell.....	7A	Talcum Powder.....	3D
Peanuts, Shelled.....	3D	Walnut Shells, Crushed.....	3D
Perlite.....	7A	Wheat.....	8A
Phosphate Rock.....	3D	Wheat, Wet.....	5A
Polyethylene Powder.....	7A	Wood, Chips.....	6G
Polyethylene Resin.....	17	Wood, Dust.....	6G
Polypropylene Fluff.....	7A		

*Diaphragm codes become 4th and 5th characters in model number.

Ultra-Mag™ Level Switch

Specifications and Ordering Information

MODEL #	DRY LEVEL MAGNETIC DIAPHRAGM SWITCH
PREFIX – CERTIFICATION	
EX =	Explosion Proof, UL & CSA, Cl 1, Div I & II Grps C & D; Cl 2, Div I & II, Grps E, F & G
X =	Explosion Proof, CSA, Cl 2, Div I & II, Grps F & G
1ST DIGIT – BASIC MAGNETIC PRESSURE SENSING SERIES	
G =	Elastomeric Diaphragm – Venting required*(Diaphragms 1A - 8A)
P =	Breathable Fabric Diaphragm – No venting required (Diaphragms 16 & 17 only)
2ND DIGIT – MOUNTING (Top = Suspension / Side = Flanged)	
S =	Suspended ("G" Series requires suspension vent fittings)* Subtract 10 lb/cu ft – greater sensitivity
F =	Flanged, Aluminum standard
T =	Flanged, 304 Stainless Steel
3RD DIGIT – HOUSING MATERIAL	
D =	Aluminum
A =	Aluminum, Anodized
E =	Aluminum, Epoxy coated
4TH & 5TH DIGITS – DIAPHRAGM MATERIAL (TEMP) (BULK DENSITY)	
G-----1A =	Fluoroelastomer, black, .025" thick, (25 to 300°F), (.30 lbs/cu ft)
G-----2A =	Neoprene, black, .025" thick, (-30 to 220°F), (.30 lbs/cu ft)
G-----3D =	Urethane, orange, .031" thick, (10 to 150°F), (.30 lbs/cu ft)
G-----3E =	Urethane, orange, .062" thick, (10 to 150°F), (.90 lbs/cu ft)
G-----3F =	Urethane, "3D" elastomer w/bumper for removable overlays, orange, (10 to 150°F), (.90 lbs/cu ft)
G-----4B =	Buna-N, black, .020" thick, (-20 to 212°F), (20 to 90 lbs/cu ft)
G-----5A =	PTFE/Glass on Sil Rubber, brown, .024" thick, (-40 to 350°F), (30 to 90 lbs/cu ft)
G-----6D =	Silicone Rubber, gray, .062" thick, (-40 to 350°F), (15 to 30 lbs/cu ft)
G-----6E =	Silicone Rubber on Glass, red, .032" thick, (-40 to 350°F), (30 to 90 lbs/cu ft)
G-----6G =	"6C" w/Urethane overlay, gray, (-40 to 350°F), (wood chips diaphragm with "A2")
G-----6H =	"6C" w/bumper for removable overlays 901-120, -132, -134, gray, (-40 to 350°F), (.90 lbs/cu ft)
G-----7A =	Silicone Rubber on Glass, white, .015" thick, (-40 to 350°F), (5 to 40 lbs/cu ft)
G-----7B =	Buna-N, white food grade, .060" thick, (-20 to 212°F), (30 to 90 lbs/cu ft)
G-----8A =	EPDM, black, .036" thick, (-40 to 275°F), (40 to 90 lbs/cu ft)
P-----16 =	Polyester Filter Fabric, white, 150 micron permeability, (-30 to 275°F), (30 to 90 lbs/cu ft)
P-----17 =	Polyester "Nitex," white, 15 micron permeability, (-30 to 275°F), (.20 lbs/cu ft)
6TH DIGIT – SWITCH TYPE	
A =	Standard, SPDT, 15 A @ 125, 250 VAC
T =	High Temp, SPDT, 5 A @ 125, 250 VAC, 24 VDC (Non-UL/CSA listed)
V =	High Vibration SPDT, 15 A @ 125, 250 VAC
G =	Gold Contacts, SPDT, 1 A @ 125 VAC; 1/2 amp, 24 VDC
SUFFIX – SPECIAL CONTROLS	
- A2 =	Wood Chips Control (with "6G" diaphragm only)
- A3 =	High sensitivity actuator (for very light product)
EX G S D 3D A	EXAMPLE OF TYPICAL MODEL NUMBER (EXGSD3DA)*

*G, GS series suspended controls require suspension vent fittings.

CONSULT FACTORY for special assemblies, housing materials, switches, fittings, accessories and applications not listed above.

NOTE: The "EX" prefix must be added to the 6-digit model number for "explosion proof standard." General purpose units do not require the "EX" or other prefix.

SUSPENSION ASSEMBLY KITS

"P" and "G" Series Suspension Assembly Kits	
Part #	Description
901-409	"P" Series Suspension Assembly includes 1/2" pipe (56" standard length), 1" pipe (48" standard length), 1" pipe coupling, 1-1/2" NPT strain relief on 1" pipe. Galvanized mild steel pipe, explosion proof, standard.
901-412	"G" Series Suspension Assembly includes 1/2" pipe (56" standard length), watertight strain relief and 1" coupling, upper 1" pipe (28" standard length), lower 1" pipe (20" standard length), strain relief with 1-1/2" male NPT (slip joint), 1" x 1" x 1" Tee, 1" Street El (elbow) and 1" pipe – 4" long Stilling Pot. Galvanized steel pipe, explosion proof, standard. Specials include aluminum or stainless steel assemblies. Flange port and cover assemblies are sold separately. CONSULT FACTORY for details.

Suspension Assembly Parts	
Part #	Description
122-015	Strain relief, slip joint, for 1" pipe
122-016	Strain relief, watertight, for 1/2" pipe
901-003	Rectangular flange port & cover, mild steel

CONTACT FACTORY for additional options.

ALUMINUM FLANGE ADAPTER RINGS

Part #	Tank OD	Part #	Tank OD
126-009	15"	126-016	84"
126-010	30"	126-017	96"
126-011	36"	126-018	10'
126-012	42"	126-019	12'
126-013	48"	126-020	14'
126-014	60"	126-021	24'
126-015	72"		

NOTE: OD = Outside Diameter

Series
TFLS

Tuning Fork Level Switch

Perfect for Sensing Low Bulk Density or Low Dielectric Materials

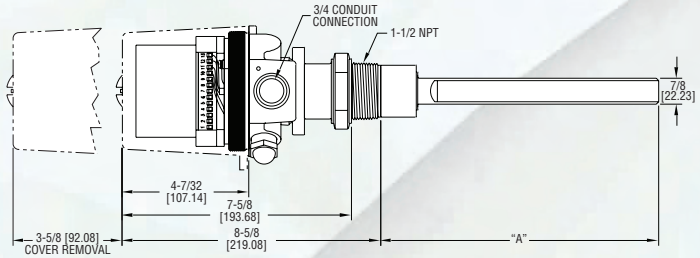
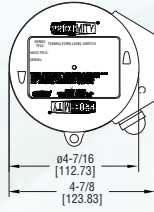

EXTENSION LENGTH	DIM "A"
NONE	9-1/4 (234.95)
6 IN	15-7/8 (403.23)
12 IN	21-7/8 (555.63)
18 IN	27-7/8 (708.03)
24 IN	33-7/8 (860.43)
36 IN	45-7/8 (1165.23)
48 IN	57-7/8 (1470.03)

Series TFLS tuning fork level switch is ideal for level control of powders and fine grained solids, especially those with a low bulk density. The TFLS incorporates a piezoelectric crystal that vibrates the fork at its natural frequency. When the fork comes in contact with material the vibration is dampened and the switch changes state. As the fork becomes free of material the switch changes back to its normal state. Featured in the TFLS is user-selectable fail-safe operation of the contacts. Unit is not affected by vibration from conveying systems, motors, or the movement of material. It can be mounted in any position and is available with factory built extensions for mounting on the top of the storage vessel.

Series TFLS is easy to use with no calibration required and with no mechanical moving parts there is no routine maintenance required. The TFLS is unaffected by the dielectric constant of the sensed material making it superior to a capacitance level switch for applications where the dielectric constant is too low, where there is more than one material being used in one vessel, and when material moisture content can change. The level switch is also good for applications when the bulk density is too low for a rotating paddle level switch. It can also detect granular material submerged in liquids of low viscosity, for example sand, gravel, or polyester chips in water.

FEATURES

- **No Calibration Required.**
- **Vibrating Fork Design:** Great for low bulk density and low dielectric constant products. Will detect products down to 1.8 lb/ft³ (30 g/l).
- **Universal Power Supply:** One model works with 90 to 265 VAC and 24 VDC.
- **Adjustable Sensitivity:** Can be set to ignore lighter bulk density products and only detect heavier products, such as sand in water.
- **Status Indication:** External LED switch indicator, and internal indicators for normal and alarm status.
- **Failsafe Setting:** Output switch can be set for Normally Open or Normally Closed condition on loss of power.
- **Time Delay:** Prevent false alarms from material surges.

TFLS-W11SR1

Contact factory for fork extension options in carbon steel or stainless steel.

SPECIFICATIONS

- **Service:** Dry powder or bulk materials compatible with wetted materials. Can detect bulk materials submerged in liquid.
- **Sensitivity:** Minimum bulk density of 1.8 lb/ft³ (30 g/l), maximum particle size 0.4 in (10 mm).
- **Wetted Materials:** 316 SS.
- **Temperature Limits:** Ambient: -4 to 140°F (-20 to 60°C). Process: -4 to 176°F (-20 to 80°C).
- **Pressure Limit:** 145 psig (10 bar).
- **Power Requirement:** 90 to 265 VAC, 50/60 Hz; 24 VDC.
- **Power Consumption:** 4 VA.
- **Enclosure:** Aluminum, powder coated.
- **Enclosure Rating:** Weatherproof, NEMA 4X.
- **Switch Type:** SPDT.
- **Electrical Rating:** 5A @ 230 VAC.
- **Electric Connections:** Screw terminals.
- **Conduit Connection:** 3/4" female NPT.
- **Process Connection:** 1-1/2" male NPT.
- **Weight:** 5.5 lbs. (2.5 kg).
- **Indication Lights:** External: red LED; Internal: green and red LED's.
- **Sensing Delay:** (Maximum) covered probe: 2 seconds; uncovered probe: 3 to 7 seconds.
- **Time Delay:** Separate settings for covering and uncovering the probe. Adjustable from 2 to 20 seconds.

APPLICATIONS

Lime, styrofoam, tobacco, dry cereals, sugar, animal feed, milk powder, flour, insulation, cement, paper shavings, plastic granules, sawdust, carbon black, light fibers, detergent powders, dyes, chalk, silica, sand, wood chips.

Series LTS Tilt Switch Probe

Non-Mercury Probes

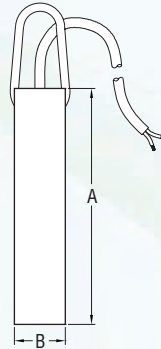

Probe Type	A in (cm)	B in (cm)
Standard	9 (22.86)	1-7/8 (47.63)
Compact	6 (15.24)	1-7/16 (36.51)

The Series LTS Tilt Switch Probes are able to sense either the presence or absence of material when other sensors won't work due to bin vibration, or actual walls aren't available for mounting other types of measuring units. The probes are designed for use where the bulk material to be sensed is exposed or open. Typical applications include high or low level detection in large hoppers, silos, crushers, or trippers, high level control under stackers, and detection of plugged conditions at conveyor transfer points. Series LTS probes can also be used to detect the presence or absence of bulk material on belt conveyors, on chutes to indicate product flow, and to aid in loading rail cars or trucks.

All probe models are airtight, dust tight, and waterproof. The compact probe should be used for applications involving small bins and hoppers where space is limited, while the heavy duty probe should be used for applications where a heavy duty abrasion-resistant probe is necessary.

Model No	Size	Probe Material
LTS-N11G-003	Standard	Steel
LTS-N21G-003	Compact	Steel
LTS-N12G-003	Standard	Stainless Steel
LTS-N22G-003	Compact	Stainless Steel

Consult factory for custom cable lengths.

SPECIFICATIONS

- Service:** Powder and bulk.
- Temperature Limit:** -40 to 150°F (-40 to 66°C).
- Switch Type:** SPST, normally closed.
- Electrical Rating:** 0.25 A max, 60 V max, 3 VA max.
- Electrical Connection:** 16-2 type SO connection cable.
- Cable Length:** 3ft (0.9 m) unless otherwise specified.
- Probe Length:** Standard: 9" (23 cm); Compact: 6" (15 cm).

- Signal Voltage:** 15 VDC.
- Actuation Angle:** 25° from vertical.
- Material:** Steel or 316 SS.
- Switch Surrounding:** Epoxy encapsulated.
- Mounting Orientation:** Vertical.
- Weight:** Standard: 4.75 lbs (2.15 kg); Compact: 2.5 lbs (1.13 kg).
- Features:** Fittings for hangers.
- Enclosure Rating:** NEMA 4.

Level/Vibrators

Series LTC Tilt Switch Control Unit

Adjustable Time Delay

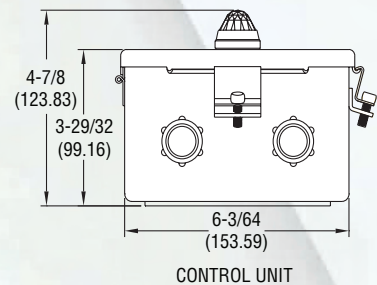
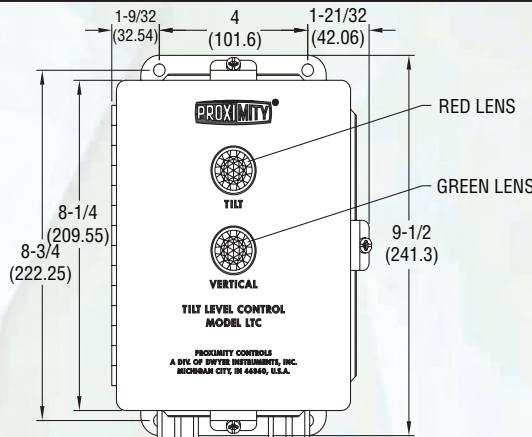

The Series LTC Tilt Probe Control Units feature an adjustable time delay and a logic selector switch. The logic selector switch determines when the output relay actuates and de-actuates, thus while in position one, the relay is energized when the probe is in the vertical position and de-energizes when the probe is in the tilted position, and while in position two, the actions are opposite. In addition, an adjustable time-delay feature may be assigned to either the vertical or the tilt position to prevent false signals. The relay assumes the de-energized position upon reaching the end of the delay period as well as upon failure of power to the controller.

Model No.	Enclosure
LTC2	NEMA 4
LTC3	No-enclosure

SPECIFICATIONS

- Temperature Limit:** 125°F (52°C).
- Power Requirements:** 115 VAC @ 50/60 Hz.
- Power Consumption:** 10W.
- Switch Type:** DPDT.
- Electrical Rating:** 10 A @ 115 VAC.
- Enclosure:** None or Carbon Steel housing with polyester coating.
- Enclosure Rating:** None or NEMA 4.

- Electrical Connections:** Screw Terminal.
- Conduit Connection:** None.
- Indicator Lights:** Green (when relay is energized and probe vertical), Red (when relay is de-energized and probe tilted).
- Indication Light Power Required:** 18 VDC.
- Time Delay:** 1 to 10 sec. Adjustment will delay output relay action.

Model
DBLM

Mini-Bin Dry Bulk Level Monitor

Compact, 4-Vane Paddle

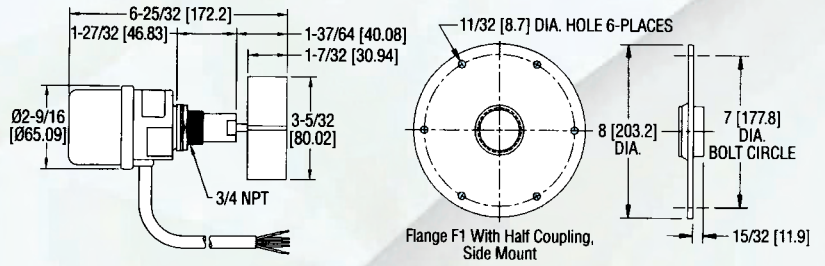

The Mini-Bin provides reliable level sensing for dry bulk solids where mounting space is limited. This compact, side mount control reports high, intermediate, and low level conditions, eliminating overflows, choking, clogs or empty vessels. Model DBLM Mini-Bin operates by using a 1 rpm synchronous motor to rotate a four vane, plastic paddle. When material surrounds paddle and impedes rotation, the motor is de-energized and triggers a SPDT snap switch. Mount the Mini-Bin with optional 1-1/4" to 3/4" reducer to replace standard size units.

Model Number	Power Supply
DBLM3040	110 VAC
DBLM3140	220 VAC

F1, 8" x 1-1/4" NPT flexible carbon steel mounting flange
A-335, 1-1/4" to 3/4" reducer

SPECIFICATIONS

Service: Dry bulk solids.

Wetted Materials: Polycarbonate paddle, stainless steel shaft, PTFE washer.

Temperature Limits: -4 to 140°F (-20 to 60°C).

Enclosure Rating: Polycarbonate, NEMA 1.

Switch Type: SPDT snap switch.

Electrical Rating: 3A @ 250 VAC.

Power Requirements: 110 VAC, 50/60 Hz, 220 VAC optional, consult factory.

Power Consumption: 1.5 Watts.

Electrical Connections: 18 AWG, 12" leads wrapped in conduit.

Process Connection: 3/4" male NPT, optional flange and 1-1/4" to 3/4" reducer.

Mounting Orientation: Side mount.

Weight: 0.77 lb (350 g).

Agency Approvals: CE.

Series
PS

Proximity Sensors

Capacitive or Inductive 3-Wire DC, Threaded Body

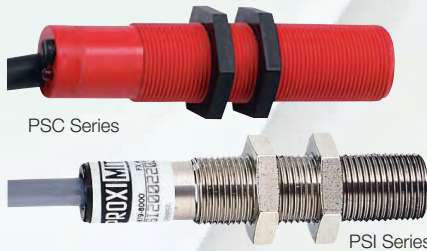

Dim.	PSC20103	PSC20203	PSI2002203	PSI2005303
A	M18	M30	M12	M18
B	1.065 (27)	1.614 (41)	0.688 (17)	0.938 (17)
C	0.157 (4)	0.197 (5)	0.125 (3)	0.125 (3)
D	3.156 (80)	3.156 (80)	2.36 (60)	2.87 (73)
E	2.36 (60)	2.36 (60)	1.58 (40)	1.97 (50)

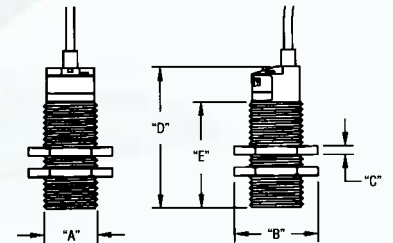

The Series PS Proximity Sensors are noninvasive sensors ideal for level detection in bins/silos/hoppers, speed indication for rotating parts such as conveying belts, or position indicating of moving parts. Capacitive type sensors detect electrically conducting and nonconducting materials, liquids, solids, or powders and include a sensitivity adjustment to differentiate between various materials. Inductive sensors detect ferrous or nonferrous metals only. A bright LED indicates the state of the output switch. Sensors feature short circuit, reverse polarity, and transient protection. Small size and threaded body make installation easy. Inductive sensors are embeddable (can be mounted flush). Capacitive sensors are environmentally protected to IP65 and Inductive sensors are protected to IP68.

Model Number	Type	Body Size	Switching Frequency	Detecting Dist. in (mm)
PSC20103	Cap.	M18 x 1	400 Hz	.04-3 (1-10)
PSC20203	Cap.	M30 x 1.5	250 Hz	.08-79 (2-20)
PSC30203*	Cap.	M30 x 1.5	250 Hz	.08-79 (2-20)
PSI2002203	Ind.	M12 x 1	800 Hz	.08 (2)
PSI2005303	Ind.	M18 x 1	500 Hz	.19 (5)

*PNP Transistor

Ⓢ Items subject to schedule B discounts

SPECIFICATIONS

Wetted Materials: Glass GRP Crastine reinforced plastic (PSC), Stainless Steel (PSI) (Model PSI2002203), Nickel-plated Brass (Model PSI2005303).

Temperature Limits: -22 to 212°F (-30 to 100°C) capacitive, -13 to 158°F (-25 to 70°C) inductive.

Enclosure Rating: PSC, IP65; PSI, IP68.

Repeatability: ±0.05% (Model PSC20103), ±0.1% (Model PSC20203), ±0.01% (PSI Models).

Power Requirements: 8 to 30 VDC.

Switch Type: Normally open NPN transistor, sinking (PSC30203:PNP).

Electrical Rating: 250 mA (PSC), 200 mA (PSI).

Minimum Load Current: 8 mA (PSC), <25 mA (PSI).

Leakage (Off-State) Current: <3 mA (PSC), <0.08 mA (PSI).

Voltage Drop: <3.5V @ 250 mA (PSC), <2.5V @ 200 mA (PSI).

Ripple: 10%.

Electrical Connection: 9.8 ft (3 m) cable.

Deadband: 20% of range (PSC), 15% of range (PSI).

Initializing Time Delay: <10 msec.

Agency Approvals: CE.

APPLICATIONS

Level control of liquids, powders, or solids, parts detection and counting, motion and speed detection, leak detection, rotation control.

Model
CLS1

Capacitance Level Switch



For Solids, Liquids or Slurries, Fail-Safe Protection, <1 pF Sensitivity

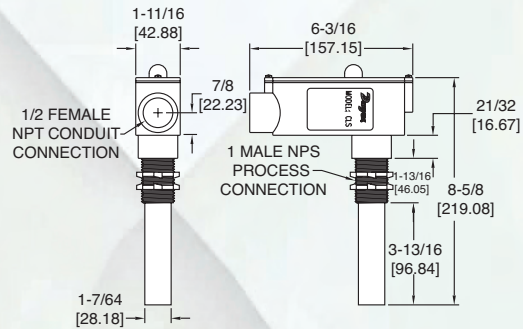

Model CLS1 Capacitance Level Switch provides reliable point level measurement of solids, liquids and slurries in metallic or non-metallic tanks and vessels. Model CLS1 detects the presence or absence of material in contact with the probe by sensing a change in the capacitance. Electronics provide highly sensitive measurement detection (requires less than a 1 picofarad shift from ambient). State of the art technology ignores material build-up on the vessel sidewall or along the probe assembly. One time calibration is simple with a single multi-turn potentiometer. Red LED on housing indicates sensor status. Unit features an adjustable 1-30 second time delay and a 5 amp, SPDT fail-safe relay output. Model CLS1 can be mounted vertically or horizontally.

Model CLS1 Capacitance Level Switch

SPECIFICATIONS

Service: Solids, liquids, or slurries.

Wetted Material: CPVC.

Temperature Limits: Probe:

-40 to 240°F (-40 to 116°C), Electronics: -40 to 185°F (-40 to 85°C).

Enclosure Rating: NEMA 4X (IP56), PVC, dust tight, water resistant.

Switch Type: SPDT.

Electrical Rating: 5A @ 250 VAC.

Power Requirements: 120 VAC, 1.5VA.

Conduit Connection: 1/2" female NPT.

Process Connection: 1" male NPS.

Mounting Orientation: Vertical or horizontal.

Sensitivity: Adjustable to <1 pF.

Fail-Safe: Switch Selectable, high/Low.

Time Delay: Adjustable 1 to 30 seconds.

Weight: 2.0 lb (0.91 kg).

Agency Approvals: CE.

APPLICATIONS

High or low level detection in bins, silos, tanks, hoppers, chutes and other vessels where liquids, solids or slurries are stored.

Series
CRF2

Capacitive Level Transmitter

Powder, Bulk or Liquids

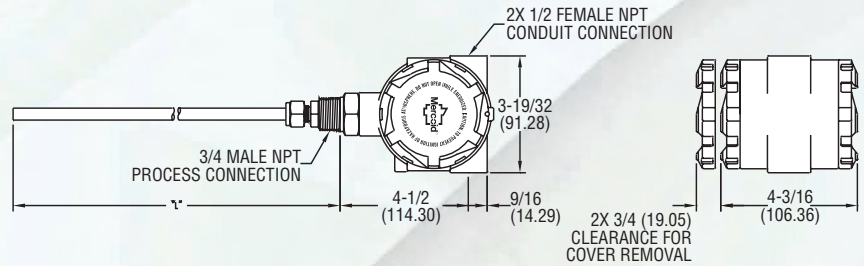

The Series CRF2 is a level transmitter providing a two-wire 4 to 20 mA output to indicate level of liquids, powders and bulk materials. State of the art sensing technology in the CRF2, using impulse RF admittance measurement provides excellent accuracy and stability. The CRF2 senses capacitance changes resulting from the height of the material in the tank between the probe and the tank wall. In non-metallic tanks or tanks that do not have the wall parallel to the probe a ground reference must be used.

The CRF2 comes with either a rigid or flexible probe depending on application installation need and probe length required. Featured in the CRF2 is easy push button calibration of zero and span. Custom order the CRF2 to any length probe that you need for your application. FEP covered probe is ideal for use with corrosive media. This technology also provides immunity to external RF sources like walkie-talkies and cell phones as well as minimal interference with radio communication or other electronic systems. The CRF2 is perfect for level indication in bins, hoppers, or small silos of powder bulk materials.

Service: Liquids, powders, and bulk materials compatible with wetted materials.

Wetted Materials: Standard: rod/cable: FEP; connection: 316 SS. Ground Option: rod/cable and connection: 316 SS; cable spacers: PVC. Flange Option: material of flange.

Capacitance Range: 0 to 2000 pF.

Sensitivity: 0.15 pF.

Minimum Span: 8 pF.

Accuracy: ± 0.5 pF or $\pm 0.25\%$ of span, whichever is greater.

Repeatability: ± 0.25 pF or $\pm 0.1\%$ of span, whichever is greater.

Temperature Limits: Ambient: -40 to 185°F (-40 to 85°C); Process: -40 to 250°F (-40 to 121°C).

Pressure Limit: 100 psi (6.9 bar).

Power Requirements: 12 to 35 VDC.

Output Signal: 4 to 20 mA or 20 to 4 mA, 2 wire.

Response Time: 0.5 seconds.

Electrical Connection: Screw terminal.

Conduit Connection: 1/2" NPT female.

Process Connection:

Standard: 3/4" NPT male.

Optional: See model chart.

Enclosure Rating: NEMA 4X (IP66) weather-tight/corrosion resistant.

Spark/Static Protection: 10⁶ Ohm dissipation resistance with spark gap. Surge current to 100A max.

Calibration: Zero, Span, 4 mA, 20 mA.

Mounting Orientation: Vertical.

Weight: 6 ft rod type: 3.6 lb (1.63 kg).

Level/Vibrators

Example	CRF2	W	R	O	1T	048	M20	CRF2-WR01T-048-M20
Series	CRF2							Capacitive Level Transmitter
Enclosure		W						Weatherproof
Probe Type			R C					Rod Cable
Ground				O A U				None Included Attached ground rod (3" or 4" flange process connection types only) Unattached ground rod
Process Connection					1T 2T 3T 1B 2B 3B 1S 2S 3S 1F 2F 3F 4F 5F 6F			3/4" NPT male 1" NPT male 1-1/2" NPT male 3/4" BSPT 1" BSPT 1-1/2" BSPT 1" sanitary clamp 1-1/2" sanitary clamp 2" sanitary clamp 2" 150# flange, 316 SS 2" 150# flange, PVC 3" 150# flange, 316 SS 3" 150# flange, PVC 4" 150# flange, 316 SS 4" 150# flange, PVC
Probe Length						XXX		Insertion length in inches. Example 048 is 48" length Rod Type: minimum: 24", maximum: 144" Cable Type: minimum: 24", maximum: 360"
Options							M20	M20 conduit connection with cable gland

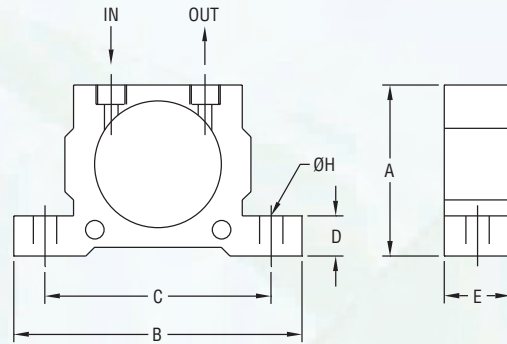

Model Number	A	B	C	D	E	H	Connection
BPV-1	2.01" (51 mm)	3.39" (86 mm)	2.68" (68 mm)	0.47" (12 mm)	0.79" (20 mm)	0.79" (ø7 mm)	1/8"
BPV-2	2.64" (67 mm)	4.45" (113 mm)	3.54" (90 mm)	0.63" (16 mm)	0.94" (24 mm)	0.94" (ø9 mm)	1/4"
BPV-3	2.64" (67 mm)	4.45" (113 mm)	3.54" (90 mm)	0.63" (16 mm)	0.94" (24 mm)	0.94" (ø9 mm)	1/4"
BPV-4	3.27" (83 mm)	5.04" (128 mm)	4.09" (104 mm)	0.63" (16 mm)	1.30" (33 mm)	1.30" (ø9 mm)	1/4"
BPV-5	3.27" (83 mm)	5.04" (128 mm)	4.09" (104 mm)	0.63" (16 mm)	1.30" (33 mm)	1.30" (ø9 mm)	1/4"
BPV-6	4.06" (103 mm)	6.30" (160 mm)	5.12" (130 mm)	0.79" (20 mm)	1.73" (44 mm)	1.73" (ø11 mm)	3/8"

Series BPV Pneumatic Ball Vibrators are the best choice for bridge-break in thin walls and small tanks. This model can be used in vibrating separators, vibrating conveyors, and against electroplating build-up. It can also be used on material compacted while packing or sand compacted while molding.

HOW IT OPERATES

The aluminum body is equipped with a steel ring and ball inside that is tightly closed by plastic side covers. Vibration is caused when the internal ball, pushed by compressed air, runs in a rotary motion to produce centrifugal force.

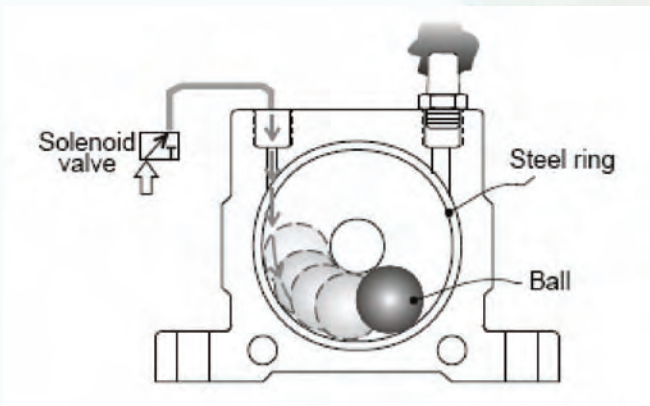

SPECIFICATIONS

Temperature Limits: 212°F (100°C).

Noise Level: 75-95 dBA.

Supply Pressure: 29 to 87 psi (2 to 6 bar).

Air Consumption: See model chart.

Air Connections: 1/4" BSPT female with 1/4" NPT female adapter on BPV-1, BPV-2, BPV-3, BPV-4, BPV-5. 3/8" BSPT female with 3/8" NPT female adapters on BPV-6. Also includes muffler for exhaust port.

Housing Material: Aluminum.

FEATURES

- The body is made of high strength aluminum alloy.
- Small in size and light-weight.
- Can be used in high humidity or dusty working areas.
- Frequency and amplitude of vibration can be adjusted as needed.

MODEL NO.	Frequency (V.P.M.)			Force lbf (N)			Air Consumption cfm (l/min)			Weight lb (kg)
	Pressure Input			Pressure Input			Pressure Input			
	29 psi (2 bar)	58 psi (4 bar)	87 psi (6 bar)	29 psi (2 bar)	58 psi (4 bar)	87 psi (6 bar)	29 psi (2 bar)	58 psi (4 bar)	87 psi (6 bar)	
BPV-1	22500	28000	34000	56 (250)	106 (470)	160 (710)	3.25 (92)	5.30 (150)	7.06 (200)	.31 (0.14)
BPV-2	15000	18500	22500	72 (320)	124 (550)	195 (870)	3.32 (94)	5.58 (158)	7.95 (225)	.57 (.26)
BPV-3	13000	17000	19500	101(450)	180 (800)	247 (1100)	4.31 (122)	7.06 (200)	9.89 (280)	.66 (.30)
BPV-4	10500	14500	16500	162 (720)	274 (1220)	387 (1720)	4.59 (130)	8.12 (230)	12.01 (340)	1.2 (.53)
BPV-5	9200	12200	14000	209 (930)	353 (1570)	461 (2050)	5.65 (160)	10.24 (290)	15.01 (425)	1.4 (.63)
BPV-6	7800	9700	12500	339 (1510)	555 (2470)	722 (3210)	7.59 (215)	13.24 (375)	20.13 (570)	2.54 (1.15)

V.P.M. = vibrations per minute

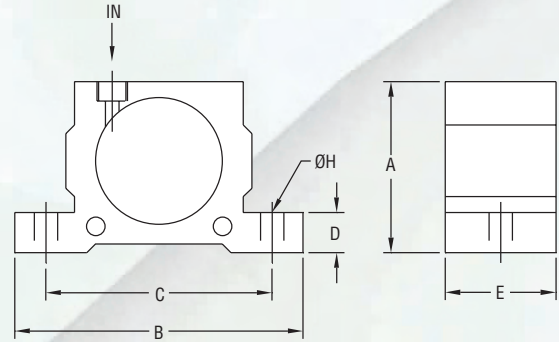

Model Number	A	B	C	D	E	øH	Connection
PRV-1	2.01" (51 mm)	3.39" (86 mm)	2.68" (68 mm)	0.47" (12 mm)	1.14" (29 mm)	0.28" (7 mm)	1/8"
PRV-2	2.64" (67 mm)	4.45" (113 mm)	3.54" (90 mm)	0.63" (16 mm)	1.46" (37 mm)	0.35" (9 mm)	1/4"
PRV-3	3.27" (83 mm)	5.04" (128 mm)	4.09" (104 mm)	0.63" (16 mm)	1.67" (42.5 mm)	0.35" (9 mm)	1/4"
PRV-4	4.06" (103 mm)	6.30" (160 mm)	5.12" (130 mm)	0.79" (20 mm)	2.05" (52 mm)	0.43" (11 mm)	3/8"

Series PRV Pneumatic Roller Vibrators have a high vibration frequency feature that can prevent material jams in pipe delivery. It can also be applied for bridge-break or concrete injection operation conditions.

HOW IT OPERATES

The special aluminum body is equipped with a roller and ring with multi-nozzles. It is tightly closed by plastic side covers. Vibration is caused when the roller pushed by compressed air runs in a rotary motion to produce centrifugal force.

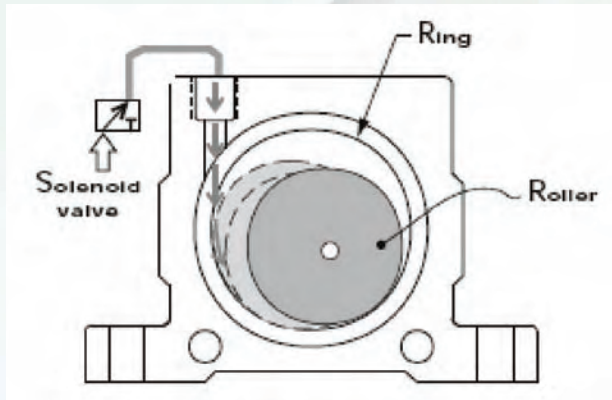

SPECIFICATIONS

Temperature Limit: 212°F (100°C).

Noise Level Range: 75-100 dBA.

Supply Pressure: 29 to 87 psi (2 to 6 bar).

Air Consumption: See model chart.

Air Connection: 1/8" BSPT female with 1/8" NPT female adapter on PRV-1. 1/4" BSPT female with 1/4" NPT female adapter on PRV-2 and PRV-3. 3/8" BSPT female with 3/8" NPT female adapter on PRV-4.

FEATURES

- Special aluminum body is small in size and light-weight.
- Frequency and amplitude of vibration can be adjusted as required.
- The strongest vibration force driven by rollers among the same size products.

MODEL NO.	Frequency (V.P.M.)			Force lbf (N)			Air Consumption cfm (l/min)			Weight
	Pressure Input			Pressure Input			Pressure Input			
	29 psi (2 bar)	58 psi (4 bar)	87 psi (6 bar)	29 psi (2 bar)	58 psi (4 bar)	87 psi (6 bar)	29 psi (2 bar)	58 psi (4 bar)	87 psi (6 bar)	lb (kg)
PRV-1	25000	35000	36000	241 (1070)	656 (2920)	948 (4200)	3.53 (100)	5.12 (145)	6.89 (195)	.53 (0.24)
PRV-2	19000	21000	26000	614 (2730)	1086 (4830)	1376 (6120)	7.06 (200)	10.59 (300)	14.13 (400)	1.19 (0.54)
PRV-3	15500	18500	19000	674 (3000)	1369 (6090)	1675 (7450)	10.24 (290)	15.19 (430)	20.13 (570)	2.1 (0.95)
PRV-4	11000	14000	16000	843 (3750)	1517 (6750)	2001 (8900)	13.07 (370)	19.42 (550)	25.78 (730)	3.97 (1.8)

V.P.M. = vibrations per minute

Series
PTV

Pneumatic Turbine Vibrator

Low Noise, High Vibration Frequency

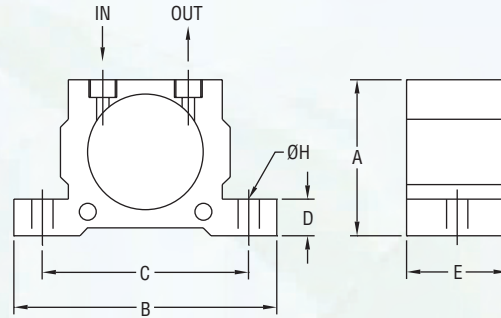

Model Number	A	B	C	D	E	H	Connection
PTV-1	2.01" (51 mm)	3.39" (86 mm)	2.68" (68 mm)	0.47" (12 mm)	1.30" (33 mm)	0.28" (ø7 mm)	1/8"
PTV-2	2.64" (67 mm)	4.45" (113 mm)	3.54" (90 mm)	0.63" (16 mm)	1.65" (42 mm)	0.35" (ø9 mm)	1/4"
PTV-3	2.64" (67 mm)	4.45" (113 mm)	3.54" (90 mm)	0.63" (16 mm)	1.65" (42 mm)	0.35" (ø9 mm)	1/4"
PTV-4	3.27" (83 mm)	5.04" (128 mm)	4.09" (104 mm)	0.63" (16 mm)	2.20" (56 mm)	0.35" (ø9 mm)	1/4"
PTV-5	3.27" (83 mm)	5.08" (129 mm)	4.09" (104 mm)	0.63" (16 mm)	2.20" (56 mm)	0.35" (ø9 mm)	1/4"

Series PTV Pneumatic Turbine Vibrators are the best choice of high vibration frequency types for a low noise environment. It is usually installed on a vibrating separator, conveyor, automatic arrangement machine, packing machine, or filling machine.

HOW IT OPERATES

The vibration is produced by centrifugal force which arises from the imbalance of movement when compressed air impacts the tangent of the turbine to make it move. The operation noise is low because of ball bearing supports on the running turbine.

SPECIFICATIONS

Temperature Limit: : 212°F (100°C).

Noise Level: 60-75 dBA.

Supply Pressure: 29 to 87 psi (2 to 6 bar).

Air Consumption: See model chart.

Air Connection: BSPT female with NPT female adapter, see dimension chart. Also includes muffler for exhaust port.

Housing Material: Aluminum.

FEATURES

- Aluminum body allows low noise and high vibration frequency
- Small in size and light-weight
- Sudden power on/off is allowed
- Frequency and amplitude of vibration can be adjusted as required

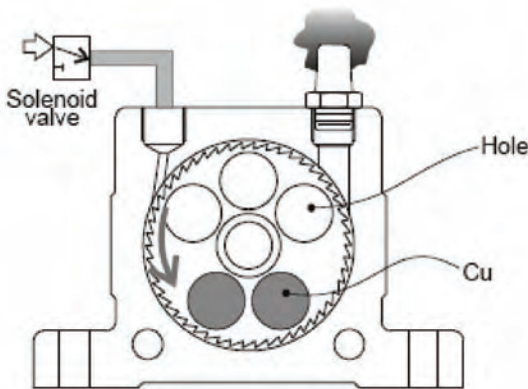

MODEL NO.	Frequency (V.P.M.) Pressure Input			Force lbf (N) Pressure Input			Air Consumption cfm (l/min) Pressure Input			Weight lb (kg)
	29 psi (2 bar)	58 psi (4 bar)	87 psi (6 bar)	29 psi (2 bar)	58 psi (4 bar)	87 psi (6 bar)	29 psi (2 bar)	58 psi (4 bar)	87 psi (6 bar)	
PTV-1	27500	35000	37500	189 (840)	312 (1390)	540 (2400)	1.62 (46)	2.83 (80)	4.0 (112)	.56 (0.26)
PTV-2	26000	30000	33000	315 (1400)	549 (2440)	839 (3730)	4.24 (120)	7.06 (200)	10.2 (290)	1.25 (0.57)
PTV-3	17000	21500	24000	274 (1220)	470 (2090)	710 (3160)	4.24 (120)	7.06 (200)	10.2 (290)	1.28 (0.58)
PTV-4	17000	20000	23000	488 (2170)	908 (4040)	1241 (5520)	6.53 (185)	11.5 (325)	16.1 (455)	2.4 (1.1)
PTV-5	12000	15500	17000	477 (2120)	789 (3510)	1140 (5070)	6.53 (185)	11.5 (325)	16.1 (455)	2.4 (1.1)

V.P.M. = vibrations per minute

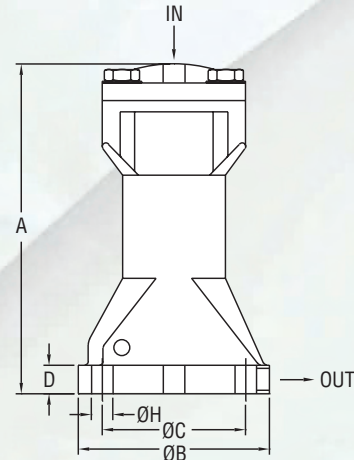
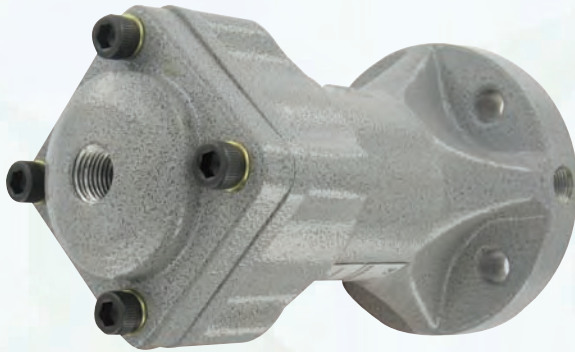

Model Number	A	ØB	ØC	D	ØH	Connection
IPV-1	5.43" (138 mm)	3.15" (80 mm)	2.36" (60 mm)	0.47" (12 mm)	0.35" (9 mm)	1/8"
IPV-2	6.54" (166 mm)	3.94" (100 mm)	2.95" (75 mm)	0.63" (16 mm)	0.43" (11 mm)	1/8"
IPV-3	8.19" (208 mm)	5.51" (140 mm)	4.13" (105 mm)	0.63" (16 mm)	0.59" (15 mm)	1/8"
IPV-4	10.56" (269 mm)	6.77" (172 mm)	5.51" (140 mm)	0.94" (24 mm)	0.75" (19 mm)	1/4"

Series IPV Air Hammer (single impact model) focuses on a limited target. Other equipment of the target is minimally affected by it. It is often applied onto a pipe or clean elbow in a tank filled with humidity or low specific gravity material.

HOW IT OPERATES

The IPV series air hammer contains a powerful magnet inside the hammer. The hammer and magnet are tightly closed before activation. As the inlet air pressure gets higher than the force, this tightens the hammer and magnet. The hammer and magnet will separate and cause more strength for impact power. The spring will bring the hammer back to the initial position automatically after the impact. By doing this, the air pressure will be released and the strength of the air pressure will be delivered to the target impact container. It will help to smooth the flow and prevent accumulation inside the container.

SPECIFICATIONS

Temperature Limit: 212°F (100°C).

Noise Level Range: 60-75 dBA.

Supply Pressure: 43.5 to 87 psi (3 to 6 bar).

Air Consumption: See model chart.

Air Connection: 1/8" BSPT female with 1/8" NPT female adapter on IPV-1, IPV-2 and IPV-3. 1/4" BSPT female adapter with 1/4" NPT female adapter on IPV-4.

FEATURES

- One impact wave caused by one shot.
- High strength aluminum structure.
- Impact force and interval timing can be set based on needs.
- Magnetic hammer stores magnetic strength to increase the piston's impact power.

MODEL NO.	Impulse	Air Consumption	Weight
	lbf-s (N-S)	in ³ (l) per stroke	lb (kg)
IPV-1	.225 (1.0)	1.71 (0.028)	2.43 (1.1)
IPV-2	.630 (2.8)	5.0 (0.082)	3.97 (1.8)
IPV-3	1.66 (7.4)	14.0 (0.228)	8.82 (4.0)
IPV-4	2.81 (12.5)	27.8 (0.455)	18.52 (8.4)

Piston Vibrator

Air Cushioned or Piston Vibrators

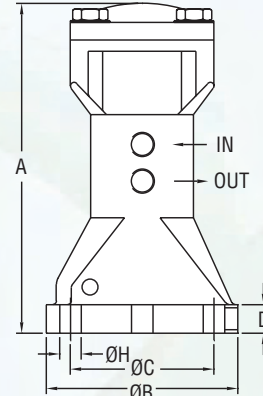

Model Number	A	øB	øC	D	øH	Connection
APV-C1	5.43" (138 mm)	3.15" (80 mm)	2.36" (60 mm)	0.47" (12 mm)	0.79" (20 mm)	1/8"
APV-C2	6.54" (166 mm)	3.94" (100 mm)	2.95" (75 mm)	0.63" (16 mm)	0.94" (24 mm)	1/4"
APV-C3	8.19" (208 mm)	5.51" (140 mm)	4.13" (105 mm)	0.63" (16 mm)	0.94" (24 mm)	1/4"
APV-I1	5.43" (138 mm)	3.15" (80 mm)	2.36" (60 mm)	0.47" (12 mm)	0.79" (20 mm)	1/8"
APV-I2	6.54" (166 mm)	3.94" (100 mm)	2.95" (75 mm)	0.63" (16 mm)	0.94" (24 mm)	1/4"
APV-I3	8.19" (208 mm)	5.51" (140 mm)	4.13" (105 mm)	0.63" (16 mm)	0.94" (24 mm)	1/4"

Series APV-C Piston Vibrators are air cushioned to provide low noise. This makes it suitable for quiet area applications. It is a good solution to prevent clogs on tank walls and material delivery problems. It can also be applied on vibrating separators and conveyors.

Series APV-I impact version piston vibrators can help to get rid of dust or material accumulated inside of pipes or tanks. It allows direct impact on the tank with low specific gravity and high moisture materials inside. It also helps prevent material build-up, pipe clogs, and rust.

HOW THEY OPERATE

There are air-breathing tubes located in both ends of the cylinder. Compressed air pushes the piston from one side to the other. Vibration power arises when the piston moves back and forth in the body. In APV-C air cushion at both ends produced by the to-and-fro motion will keep the piston from striking the body. Therefore, the piston will not produce much noise. In APV-I, air cushion at the top end is produced by the to-and-fro compression. This will keep the piston from striking onto the body top. The piston will strike directly on the bottom side of the body to produce a strong impact.

SPECIFICATIONS

Temperature Limit: 212°F (100°C).

Noise Level Range: APV-C: 60-75 dBA. APV-I: 80-115 dBA.

Supply Pressure: 29 to 87 psi (2 to 6 bar).

Air Consumption: See model chart.

Air Connection: BSPT female with NPT female adapter, see dimension chart. Also includes muffler for exhaust port.

Housing Material: Aluminum.

FEATURES

- The body is made of high strength aluminum alloy.
- APV-C: Low frequency vibration is the best solution to Bridge-break.
- APV-I: Allows direct impact onto the target object to produce the optimum vibration.
- Frequency and amplitude can be adjusted as needed.
- Sudden Power on/off will not damage.
- Movement by air, easy operation, and no sparking. They can be installed in hazardous areas or high humidity work environments.

MODEL NO.	Frequency (V.P.M.) Pressure Input			Force lbf (N) Pressure Input			Air Consumption	Weight
	29 psi (2 bar)	58 psi (4 bar)	87 psi (6 bar)	29 psi (2 bar)	58 psi (4 bar)	87 psi (6 bar)	cfm (l/min)	lb (kg)
APV-C1	1765	2308	2857	44 (195)	85 (380)	126 (560)	8.12 (230)	1.98 (0.9)
APV-C2	1333	1677	1875	62 (275)	119 (531)	161 (715)	8.79 (249)	4.19 (1.9)
APV-C3	1000	1200	1340	91 (404)	175 (780)	231 (1030)	9.50 (269)	9.92 (4.5)
APV-I1	1973	2885	3571	1818 (8086)	3044 (13542)	3996 (17776)	8.8 (250)	2.2 (1.0)
APV-I2	1744	2459	3000	3245 (14443)	4934 (21948)	6048 (26904)	9.5 (270)	4.6 (2.1)
APV-I3	1277	1875	1973	3470 (15434)	7799 (34692)	8276 (36816)	10.6 (300)	10.6 (4.8)

V.P.M. = vibrations per minute

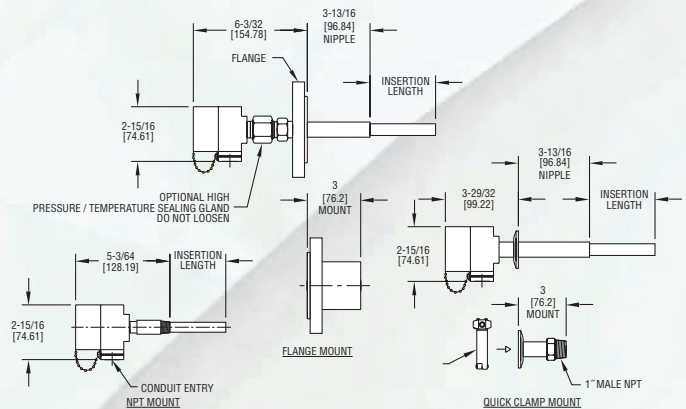

The **PMS Particulate Sensor** employs a field-proven combination of passive-induction and protected-probe technologies. As particles flow near and around the probe, minute currents are dynamically induced into the probe by flowing particulate. A DSP processes the signal into an absolute output that is reasonably linear to mass. Protective layers over the probe work in combination with induction-sensing to ensure reliable operation with all types of particulate including moist powders and highly conductive dusts. Maintenance is minimal and there is no need for an air purge. For durability, the sensors are passive and free of electronics. The PMS Particulate Sensor is designed to be used with the DPM Particle Monitor in order to be intrinsically safe.

PMS Particulate Sensor

- More effective control than “broken bag detectors”.
- Protect downstream blowers, oxidizers, HEPAs, etc.
- For baghouses, cartridge filters, bin vents, and cyclones.
- Repeatable in all applications (conductive and moist dusts).

How To Order:

Determine model number from model chart using example as a guide. Also, select desired length of Particulate Sensor cable from cable model chart.

Example	PMS	A1	1	T1	P1	L1.5	PMS-A11T1P1-L1.5: PMS Particulate Sensor, Weatherproof, NEMA 4X, 1/2" NPT Connection, 250°F Max Temp., 10 psi Max Pressure, 1.5" Probe.
Series Designator	PMS						PMS Particulate Sensor
Enclosure Rating		A1 AHZ1					Weatherproof, NEMA 4X Intrinsically Safe, CSA & CEA Approvals, Class I, II, and III. Division I & II, All Groups, NEMA 4X (requires sanitary connection or flange mount)
Process Connection			1 2 3 4				1/2" NPT 1" NPT with 1.5" Sanitary Connection 2" 150# ANSI Flange 2" 150# ANSI Flange with Process Mating Flange and Installation Kit
Maximum Process Temperature				T1 T2 T3 T4			250°F (121°C) 450°F (232°C) 800°F (426°C) - requires flange mount 1200°F (649°C) - requires flange mount
Maximum Process Pressure					P1 P2		10 psi 100 psi - requires flange mount
Insertion Length (Recommended at Least 1/2 Duct Diameter)						L1.5 L03 L05 L10 L15 L20 L30 L36 L48 L60 L72	1.5" Probe 3" Probe 5" Probe 10" Probe 15" Probe 20" Probe 30" Probe 36" Probe 48" Probe 60" Probe 72" Probe

Model No.	Description	Model No.	Description
CAB-10	10 foot sensor cable	CAB-30	30 foot sensor cable
CAB-20	20 foot sensor cable	CAB-40	40 foot sensor cable

SPECIFICATIONS

- Service:** Air and compatible gases, any type particulate.
- Wetted Materials:** T1 and T2: 316SS and PFA; T3 and T4: 316SS and ceramic.
- Minimum Detection:** 5.0 pA.
- Temperature Limits:**
Ambient: Maximum -40 to 392°F (-40 to 200°C) (Maximum must be calculated for each application).
Process: See model chart.
- Pressure Limits:**
Standard: Full vacuum to 10 psi (0.69 bar),
Optional: 100 psi (6.89 bar).
- Output Signal:** pA.
- Electrical Connection:** Low noise coaxial.
- Process Connection:** See model chart.
- Enclosure:**
Standard: Painted cast aluminum, Weatherproof, NEMA 4X,
Optional: Intrinsically Safe, CSA (must use with proper DPM model).
- Weight:** Varies depending on length of probe and type of mount.
- Agency Approvals:** CE, CSA

Particulate/Air Velocity

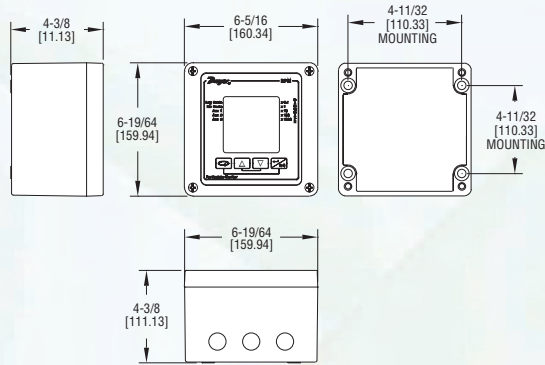

The **DPM Particle Monitor** and PMS Particulate Sensor combine to provide a basic baghouse and cartridge filter leak detector designed for general maintenance planning and process protection. It is easy to use and reliable. Leakage is gauged in real-time, on-the-spot, without prior baseline data and without signal tuning. Simply apply power and the general condition of the filter is quickly determined. An alarm point is set by simply moving an indicator up and down the gauge with the convenient, lockable key pad. For more precise alarm setup the large display provides both a logarithmic analog bar graph and an absolute digital readout. The log scale enables the user to observe both the baseline bleed through and the high peaks that are caused by filter cleaning cycles and developing leaks. Observation of both baseline and peaks is essential to setting proper alarms. The digital readout in absolute units ensures correct interpretation of the readings and provides accurate historical comparisons.

The **DPM Particle Monitor** is housed in a rugged cast aluminum enclosure. An LCD displays particulate levels in bar-graph and digital forms. A lockable membrane keypad is provided for setup and adjustment.

Together the **DPM Particle Monitor and the PMS Particle Sensor**:

- Prevent false readings from:
 - Moist and conductive dusts
 - Corrosive gases and condensate
 - Dust buildup
- For baghouses, cartridge filters, bin vents, and cyclones
- Protect downstream blowers, oxidizers, HEPAs, etc.
- Keep a clean workplace and be a good neighbor

SPECIFICATIONS

Inputs: From PMS Sensor.

Output Ratings: Alarm Relays: 2 Form A (SPST) rated 5A @ 240V res. (must provide an 8A (maximum) fuse in series with relay load).
Analog: 4 to 20 mA (Option RC).

Power Requirements: 115 VAC 50/60Hz, 230 VAC 50/60Hz, or 24 VDC.

Power Consumption: 6 Watts Max.

Accuracy: Standard: ±5% of range, Optional: ±1% of range.

Display: LCD.

Display Resolution: Standard: 5 pA, Optional: 0.5 pA.

Memory Backup: For set point storage only.

Temperature Limits: -13 to 160°F (-25 to 70°C).

Weight: 4.5 lbs (2.0 kg)

Enclosure: Cast Aluminum, Weatherproof, NEMA 4X.

Loop Power Supply (Isolated): 17 VDC loop supply provided by DPM control unit for PMS Sensor.

Agency Approvals: CE & CSA.*

Model No.	System Rating	Range	Input Power
DPM-A111	Weatherproof/NEMA 4X	5.0 pA - 5000 pA	115 VAC 50/60Hz
DPM-A112	Weatherproof/NEMA 4X	5.0 pA - 5000 pA	230 VAC 50/60Hz
DPM-A113	Weatherproof/NEMA 4X	5.0 pA - 5000 pA	24 VDC
DPM-A121	Weatherproof/NEMA 4X	0.5 pA - 5000 pA	115 VAC 50/60Hz
DPM-A122	Weatherproof/NEMA 4X	0.5 pA - 5000 pA	230 VAC 50/60Hz
DPM-A123	Weatherproof/NEMA 4X	0.5 pA - 5000 pA	24 VDC
DPM-AHZ111	Intrinsically Safe*	5.0 pA - 5000 pA	115 VAC 50/60Hz
DPM-AHZ112	Intrinsically Safe*	5.0 pA - 5000 pA	230 VAC 50/60Hz
DPM-AHZ113	Intrinsically Safe*	5.0 pA - 5000 pA	24 VDC
DPM-AHZ121	Intrinsically Safe*	0.5 pA - 5000 pA	115 VAC 50/60Hz
DPM-AHZ122	Intrinsically Safe*	0.5 pA - 5000 pA	230 VAC 50/60Hz
DPM-AHZ123	Intrinsically Safe*	0.5 pA - 5000 pA	24 VDC

Options

Analog Output (4-20 mA), add **-RC** to the end of the model number

*DPM models listed intrinsically safe are to be used with corresponding intrinsically safe PMS models making an intrinsically safe control loop. The PMS model can then be installed in a hazardous location according to approval ratings listed. The DPM itself is not intrinsically safe and must be installed outside the hazardous location.

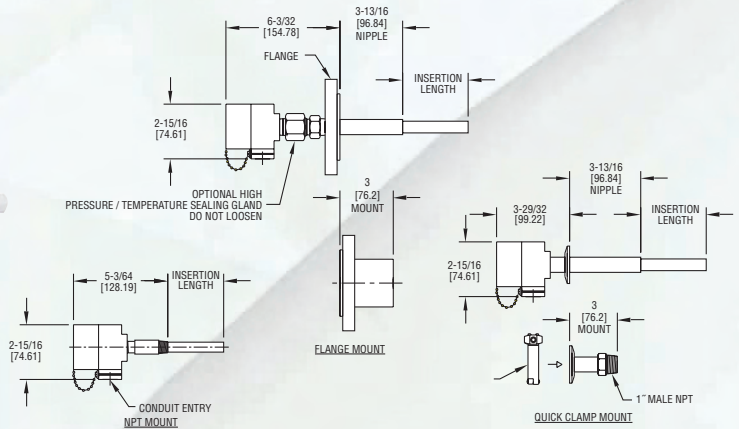

The **Series PMT Particulate Transmitter** is a reliable dust collector emissions monitor and leak detector. The loop powered design is ideal for direct connection to existing PLCs or other baghouse diagnostic control systems. Adjustable linear or logarithmic output scaling enables trending both the baseline emissions and the high peak emissions that are caused by filter cleaning cycles and developing leaks. Observation of both baseline and peaks is essential to setting proper alarms.

The PMT Particulate Transmitter employs a field-proven combination of induction and protected-probe technologies. As particles flow near and around the probe, minute currents are dynamically induced into the probe. The signal is processed into an absolute output relative to the amount of particulate and thus leakage. Protective-layers over the probe work in combination with induction-sensing to ensure reliable operation with all types of particulate including moist powders and highly conductive dusts. Maintenance is minimal and there is no need for an air purge.

The Series PMT Particulate Transmitter:

- For baghouses, cartridge filters, bin vents, and cyclones
- Simple, low cost 2-wire installation for PLCs
- Prevent false readings from:
 - Moist and conductive dusts
 - Corrosive gases and condensate
 - Dust buildup
- Protect downstream blowers, oxidizers, HEPAs, etc.
- Repeatable in all applications (conductive and moist ducts)

SPECIFICATIONS

- Service:** Air and compatible gases, any type particulate conductive or non-conductive.
- Wetted Materials:** 316 SS and PFA.
- Air Velocity Range:** 300 ft/min and higher.
- Minimum Detection:** Standard: 10.0 pA, Optional: 5.0 pA and 0.5 pA.
- Temperature Limits:**
 - Ambient: -15 to 160°F (-25 to 70°C)
 - Process: Standard: -40 to 250°F (-40 to 120°C), Optional: -40 to 450°F (-40 to 232°C).
- Pressure Limit:** 10 psi (0.69 bar).
- Power Requirement:** 18-28 VDC (24V Nominal).
- Output Signal:** 4-20 mA.
- Loop Resistance:** 300 Ohms maximum.
- Current Consumption:** Powered from 4-20 mA loop.
- Electrical Connection:** Terminal Block.
- Process Connection:** See Model Chart.
- Enclosure Rating:** Weatherproof, NEMA 4X (IP 66).
- Mounting Orientation:** Any.
- Weight:** Varies with length of probe and type of mount.
- Agency Approvals:** CE, CSA.

Example	PMT	A1	1	T1	P1	L1.5	PMT-A11T1P11-L1.5: PMT Particulate Transmitter, Weatherproof/NEMA 4X, 1/2" NPT Connection, 250°F Max Temp., 10.0 psi Max Pressure, 10.0 pA -1.5" Probe.
Series Designator	PMT						PMT Particulate Transmitter (1-piece configuration, Sensor included in price)
Enclosure Rating		A1 AHZ2					Ordinary/General Purpose Locations, CE Approval, NEMA 4X, CSA Hazardous Location, CSA Approval, Class I, Division II, Groups A-D. Class II, Groups F, G
Process Connection			1 2 3 4				1/2" NPT 1" NPT with 1.5" Sanitary Connection 2" 150# ANSI Flange 2" 150# ANSI Flange with Process Mating Flange and Installation Kit
Maximum Process Temperature				T1 T2			250°F (120°C) 450°F (232°C)
Maximum Process Pressure					P1		10 psi
Range						1 2 3	10.0 pA - 5000 pA 5.0 pA - 5000 pA 0.5 pA - 5000 pA (required for low levels or EPA leak detection)
Insertion Length (Recommended at Least 1/2 Duct Diameter)						L1.5 L03 L05 L10 L15 L20 L30 L36	1.5" Probe 3" Probe 5" Probe 10" Probe 15" Probe 20" Probe 30" Probe 36" Probe

Series
471

Digital Thermo-Anemometer

Accurate Device For Balancing Air Flows At Start-Up



Model 471-1



Model 471-2 w/
Telescopic Probe



Model 471-3 w/
Telescoping Bendable Tip

The **Series 471 Digital Thermo Anemometers** are versatile dual function instruments that quickly and easily measure air velocity in four field selectable ranges, in either feet per minute or meters per second, plus air temperature in °F or °C. High contrast LCD display shows both range selected and present velocity. Convenient backlight provides perfect visibility in low light conditions. Light automatically shuts off after 2-1/2 minutes to prolong battery life. Low battery warning is included.

Stainless steel probe with comfortable hand grip is etched with insertion depth marks from 0-8 inches and 0-20 cm on the Model 471-1. When fully extended, the probe length on models 471-2 and 471-3 reach 33 inches (83 cm). Model 471-3 features a telescoping bendable probe for easy access in hard-to-reach locations.

Extruded aluminum housing fully protects electronics, yet is lightweight and comfortable to hold even when taking multiple readings as part of duct traverses. An integral sliding cover protects sensors when not in use.

Standard accessories are 9 volt alkaline battery, wrist strap, custom fitted carrying case and step drill for making duct holes from 3/16" to 1/2". The 471 is ideal for OEM's that need to balance system air flows at start-up.

SPECIFICATIONS

AIR VELOCITY SPECIFICATIONS:

Service: Air.

Range: Field Selectable 0-500, 0-1500, 0-5000, 0-15000 FPM (see chart for Metric Conversions).

Accuracy: Depending on range (See chart) @ 59 to 86°F (15 to 30°C). Outside this range add 0.11% per °F (0.2% per °C).

Temperature Limits: Probe: 0 to 200°F (-18 to 100°C).

Ambient: 32 to 104°F (0 to 40°C).

Display: 4-1/2 Digit 0.4" High.

Resolution: 1 FPM / 0.1 MPS.

Response Time: 15 Seconds.

Power Requirements: 9 volt alkaline battery, included.

Probe: 5/16" (8.13 mm) diameter probe with integral hand grip and 6 ft. (15.2 cm) coiled cord. Length of probe: Model 471-1=10" (25.4 cm); Models 471-2 and 471-3= 33" (83 cm) extended.

Weight: 12 oz (340 g).

TEMPERATURE SPECIFICATIONS:

Range: 0 to 200°F (-18 to 100°C).

Accuracy: ±2°F (1°C).

Temperature Limits: Probe: 0 to 200°F (-18 to 100°C).

Ambient: 32 to 104°F (0 to 40°C).

Display: 4-1/2 Digit 0.4" high.

Resolution: 0.1°.

Response Time: 30 Seconds.

Note: Ranges are field selectable.

Range Number	Velocity, FPM	Velocity, MPS	Accuracy
1	0-500	0-3.0	±3% F.S.
2	0-1500	0-7.0	±3% F.S.
3	0-5000	0-30	±4% F.S.
4	0-15000	0-75	±5% F.S.

Model 471-1 Digital Thermo Anemometer

includes battery, wrist strap, 6-step drill, carrying case and instructions.

Model 471-2 Digital Thermo Anemometer

with telescoping probe includes battery, wrist strap, 6-step drill, carrying case and instructions.

Model 471-3 Digital Thermo Anemometer

with telescoping bendable tip includes battery, wrist strap, 6-step drill, carrying case and instructions.

Air Velocity Kits

Digital Manometer and Pitot Tube for Balancing System Air Flows

Model 475-1-FM-AV

Convenient all-in-one kit is small, light and easy to use. No set-up or leveling needed. Digital manometer reads from 0-19.99 in. w.c. with $\pm 0.5\%$ F.S. accuracy and minor divisions to 0.01. Large 1/2" LCD readout is easy to see in poorly lighted areas and has "low battery" warning. Included is a 6" stainless steel Pitot tube with integral compression fitting to hold it securely when taking readings. Also, two static pressure tips with magnetic mounting measure pressure drop across filters, condenser coils, etc. Kit comes complete with rubber tubing, 9V battery, step drill, AV calculator slide rule, and custom fitted carrying case. An indispensable test kit for the plant engineer and HVAC technician that must balance system air flows at start-up.

475-1-FM-AV Air Velocity Kit

Complete Kit Includes:

- Model 475-1 Digital Manometer, range 0-19.99 in. w.c.
- Model 166-6-CF, 6" Pitot Tube with Compression Fitting
- Two No. A-303 Static Pressure Tips with Magnetic Mounting
- Two 9 Ft. Lengths 3/16" I.D. Rubber Tubing
- No. A-397 Step Drill for 3/16"-1/2" Holes in 1/16" Increments
- No. A-532 AV Slide Chart
- 9 Volt Battery
- Fitted Polyethylene Case



Model 475-1T-FM-AV

Convenient all-in-one kit is small, light and easy to use. No set-up or leveling needed. Digital manometer reads from 0-19.99 in. w.c. with $\pm 0.5\%$ F.S. accuracy and minor divisions to 0.01. Large 1/2" LCD readout is easy to see in poorly lighted areas and has "low battery" warning. Kit includes convenient telescoping Pitot tube, Model 166T, fully adjustable from 11.5 to 36 inches (29.2 to 91.4 cm). Also, two static pressure tips with magnetic mounting measure pressure drop across filters, condenser coils, etc. Kit comes complete with rubber tubing, 9V battery, step drill, AV calculator slide rule, and custom fitted carrying case. An indispensable test kit for the plant engineer and HVAC technician that must balance system air flows at start-up.

475-1T-FM-AV Air Velocity Kit

Complete Kit Includes:

- Model 475-1 Digital Manometer, range 0-19.99 in. w.c.
- Model 166T, 36" Telescoping Stainless Steel Pitot Tube
- Two No. A-303 Static Pressure Tips with Magnetic Mounting
- Two 4 1/2 Ft. Lengths 3/16" I.D. Rubber Tubing
- No. A-397 Step Drill for 3/16"-1/2" Holes in 1/16" Increments
- No. A-532 AV Slide Chart
- 9 Volt Battery
- Fitted Polyethylene Case



Model 477-1T-FM-AV

Convenient all-in-one kit is small, light and easy to use. No set-up or leveling needed. Digital manometer reads from 0-20 in. w.c. with $\pm 0.5\%$ F.S. accuracy. The Series 477 stores up to 20 readings in memory for later reference, instantly selecting up to nine English/Metric pressure units that are visible on a large, backlit 0.4" LCD readout. Both audible and visual overpressure alarms and a "low battery" warning are standard features. Each kit includes convenient telescoping Pitot tube, Model 166T which is fully adjustable from 11.5 to 36 inches (29.2 to 91.4 cm). In addition, two static pressure tips with magnetic mountings measure pressure drop across filters, condenser coils, etc. Kit comes complete with rubber tubing, 9V battery, step drill, AV calculator slide rule, and custom fitted carrying case. An indispensable test kit for the plant engineer and HVAC technician that must balance system air flows at start-up.

477-1T-FM-AV Air Velocity Kit

Complete Kit Includes:

- Model 477-1 Digital Manometer, range 0-20 in. w.c.
- Model 166T, 36" Telescoping Stainless Steel Pitot Tube
- Two No. A-303 Static Pressure Tips with Magnetic Mounting
- Two 4 1/2 Ft. Lengths 3/16" I.D. Rubber Tubing
- No. A-397 Step Drill for 3/16" - 1/2" Holes in 1/16" Increments
- No. A-532 AV Slide Chart
- 9 Volt Battery
- Fitted Polyethylene Case



Stainless Steel Pitot Tubes

ASME Design Meets AMCA and ASHRAE Codes

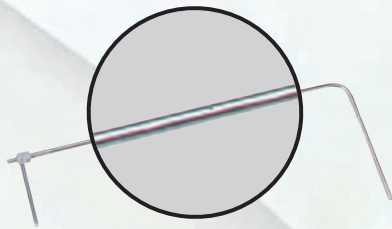

Standard Model 160 Pitot Tube

Ideal for use with our precision manometers and air velocity gages, Dwyer® Pitot Tubes are constructed from corrosion resistant stainless steel for a lifetime of service. ASME design meets AMCA and ASHRAE specifications for maximum accuracy over a wide variety of flow conditions. No correction factors required as ASHRAE tip design yields a calibration factor of 1. ASHRAE design needs no calibration! Permanent, stamped insertion depth graduations on sides of 160 series facilitate accurate positioning. Static pressure port is parallel to sensing tube allowing quick, easy alignment of tube with air flow. Low sensitivity to misalignment gives accurate reading even when tube is misaligned up to 15 degrees. Various standard sizes are available for use in ducts as small as 4" dia. or as large as 36 ft. dia. A universal model fits user supplied 3/4" schedule 40 (standard) pipe in any length. Several convenient mounting options are available for permanent installations. The 160 Pitot Tubes are an easy solution for installing in plant duct work to determine proper flow rates when combined with the appropriate gage, switch, or transmitter.

- No calibration needed.
- Hemispherical tip design, best for accuracy if imperfectly aligned and nearly impossible to damage.
- Long lasting 304 SS construction.
- Coefficient of "1."
- Inch graduations on sides of 160 series to quickly determine exact insertion depth.
- Dwyer® Air Velocity Calculator, direct reading flow charts and instructions included.
- Use 1/8" models in ducts as small as 4", 5/16" models in ducts 10" or larger.
- Optional mounting gland or split flange make permanent installation fast and simple.

Series 160 is designed to meet:

- ASME "Fluid Meters" 6th Ed.
- ANSI/AMCA 210-99
- ANSI/ASHRAE 51-1999
- British Standard 1042



A-158 Split Flange Mounting

ACCESSORIES

No. A-158 Split Flange Mounting can be added to any Dwyer® No. 160 Standard Pitot Tube. Cadmium plated steel. Gasket is pattern for mounting holes. Secure flange loosely to tube, adjust tube depth and tighten screws. Gasket of 1/16" Neoprene fits tightly around tube and against duct for leak-proof seal. Nuts, washers included.

No. A-159 Mounting Gland — No. A-159 Mounting Gland — Versatile adapter slips on any Series 160, 5/16" standard Pitot tube made after Dec. 1990. Two-part stainless steel fitting slides over tube and provides permanent, secure mounting. Where duct interior is accessible, use the washers and jam nut supplied. For blind applications or in thicker materials, use model A-156 flange mounting plate. Once tube is adjusted to proper depth and angle, tighten smaller hex bushing to lock position. Graphite bushing inside assures leak-proof seal even at higher temperatures. TFE bushing also available. **NOTE:** For full insertion with this fitting, order next longer Pitot tube.

A-159 Mounting Gland is used for both duct mounting and flange mounting. To flange mount, the A-159 must be used with the A-156 flange mounting plate.



A-159 Duct Mounting Gland with 1/2" male NPT



A-156 Flange Mounting Plate with 1/2" female NPT



A-397 Step Drill

No. A-397 Step Drill. For fast, convenient installation of Pitot tubes in sheet metal ducts. No center punch needed; automatic de-burring. Drills six sizes from 3/16" - 1/2" in 1/16" increments.

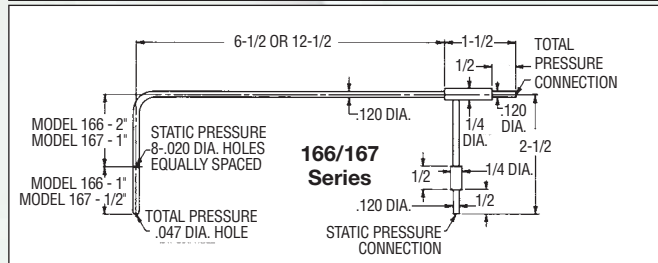
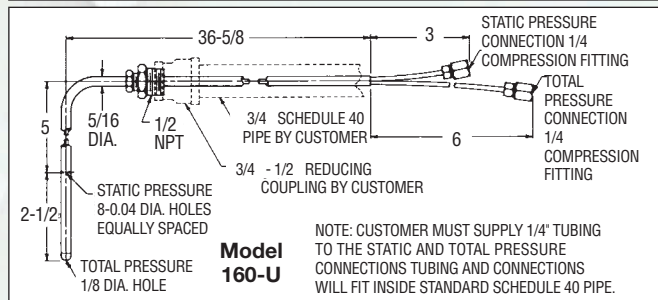
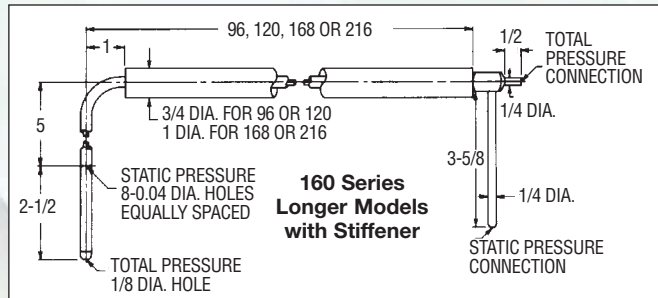
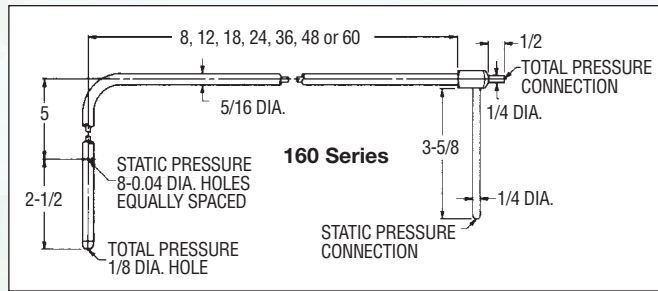

Standard 5/16" Dia.		Longer Length w/ Stiffener	
Model Number	Insertion Length	Model Number	Insertion Length
160-8	8"	160-96	96"
160-12	12"	160-120	120"
160-18	18"	160-168	168"
160-24	24"	160-216	216"
160-36	36"	Pocket Size 1/8" Dia.	
160-48	48"	166-6	6"
160-60	60"	166-12	12"
Universal Model for 3/4" Pipe		167-6	6"
160-U	*	167-12	12"

Accessories & Options	
A-156, Flange Mounting Plate 1/2" female NPT	Compression Fitting mounting option for 166/167 Series. Add -CF suffix (166-6-CF).
A-158, Split Flange	
A-159, Mounting Gland	
A-397, Step Drill	

*Universal model for permanent installation and connection to metal tubing. Make any length Pitot tube with 3/4" schedule 40 pipe, 3/4" to, 1/2" reducing bushing and 1/4" metal tubing.

Particulate/Air Velocity

Series
641B

Air Velocity Transmitter

8 Field Selectable Ranges in FPM or MPS

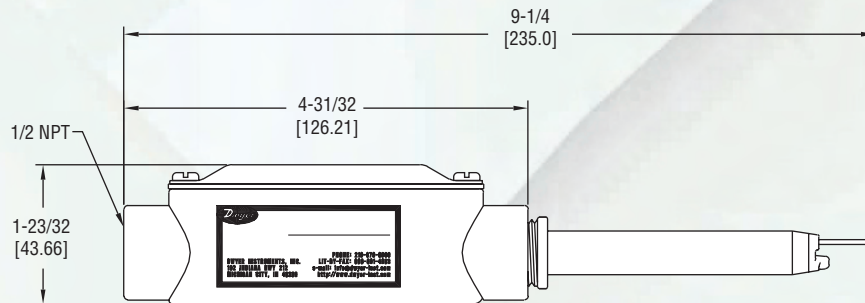

The **Series 641B Air Velocity Transmitter** uses a heated mass flow sensor technology. It has 4 user-selectable ranges from 250 FPM to 2000 FPM with corresponding metric ranges of 1.25 MPS to 10 MPS. The 641B provides an isolated 4-20 mA output proportional to the velocity.

The Series 641B's steel sensor allows the unit to be used in dirty air environments. This rugged sensor is ideally suited for quick field cleaning from a simple cloth to a pulse of air from an air source. Proper sensor performance can be maintained in these polluted environments by easily removing dust and debris from the sensor which is problematic for pitot tubes and other flow sensing transmitters.

Series 641B-4 Air Velocity Transmitter

ACCESSORIES

A-156, Flange Mounting Plate with 1/2" female NPT

A-155, Mounting Gland with 1/2" male NPT fitting

SPECIFICATIONS

Service: Air and compatible, non-combustible gases.

Accuracy:

5% FS Process gas: 32 to 122°F (0 to 50°C).

6% FS Process gas: -40 to 32°F & 122 to 176°F (-40 to 0°C & 50 to 80°C).

Response Time: Flow: 1.5 seconds to 95% of final value (Output filter set to minimum).

Temperature Limits: Process: -40 to 176°F (-40 to 80°C). Ambient: 32 to 140°F (0 to 60°C).

Humidity Limit: Non-condensing.

Power Requirements: 12–35 VDC, 10–16 VAC.

Output Signal: 4–20 mA, isolated 24V source, 3 or 4-wire connection.

Output Filter: Selectable 0.5 –15 (seconds).

Loop Resistance: 600 ohms max.

Current Consumption: 300 mA max*.

Electrical Connections: Screw terminal.

Enclosure Rating: Designed to meet NEMA 4X.

Mounting Orientation: Unit not position sensitive.

Weight: 12.6 oz (357.2 g).

* A brief current transient exceeding 300 mA may be seen on startup.

Series
641RM

Air Velocity Transmitter with Cable

For Remotely Mounting Electronic Enclosure

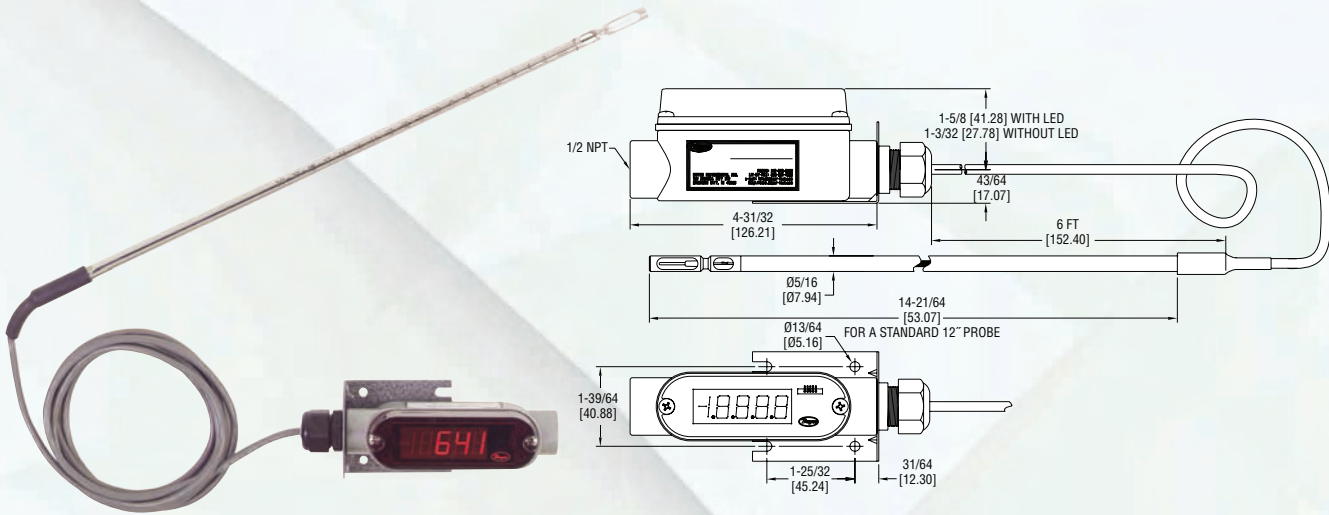

The Series 641RM is the ideal instrument for monitoring air flow. This transmitter uses a heated mass flow sensor, which allows for precise velocity measurements at various flow rates and temperatures. The 641's 16 field selectable ranges from 0-250 to 15,000 FPM (0-1.25 to 75 MPS) provide it the versatility to be selected for a multitude of applications. The unit's 6' cable which connects the sensing probe with the electronic enclosure allows the enclosure to be mounted where it can be more easily accessed. Longer cable lengths are available for ducts that are at very high elevations from the plant floor. The optional LED produces a complete, compact solution for local indication of air flow. The 641RM is to be used with clean air only and is ideal for monitoring air flow after the air has passed through the filters.

Model 641RM-12, Air Velocity Transmitter with 6' cable

Model 641RM-12-LED, same as above with LED display

ACCESSORIES

A-156 Universal Mounting Plate, 1/2" female NPT

No. A-159 Duct Mounting Gland

No. A-158 Split Flange Mounting Kit

SPECIFICATIONS

Service: Clean air and compatible, non-combustible gases.

Accuracy:

3% FS Process gas: 32 to 122°F (0 to 50°C).

4% FS Process gas: -40 to 32°F & 122 to 212°F

(-40 to 0°C & 50 to 100°C).

Response Time: Flow: 1.5 seconds to 95% of final value (output filter set to minimum).

Temperature Limits: Process: -40 to 212°F (-40 to 100°C). Ambient: 32 to 140°F (0 to 60°C).

Pressure Limit: 100 psi (6.89 bar) maximum.

Humidity Limit: Non-Condensing.

Power Requirements: 12-35 VDC, 10-16 VAC.

Output Signal: 4-20 mA, isolated 24V source, 3 or 4-wire connection.

Output Filter: Selectable 0.5-15 (seconds).

Loop Resistance: 600 ohms max.

Current Consumption: 300 mA max.

Electrical Connections: Screw terminal.

Mounting Orientation: Unit not position sensitive.

Probe must be aligned with airflow.

Weight: 13.2 oz (374.26 g).

Cable Length: 6 ft (1.82 m).

Probe Length: 12" (30.48 cm) standard.

Probe Diameter: 5/16" (0.79 cm).

OPTIONAL DISPLAY VERSION:

Display: 4-1/2 digit 1/2" red LED.

Resolution: 1 FPM, 0.01 MPS
(10 FPM @ 10,000 and 15,000 FPM ranges).

Weight: 13.9 oz (394.16 g).

Air Velocity Transmitter

16 Field Selectable Ranges in FPM or MPS

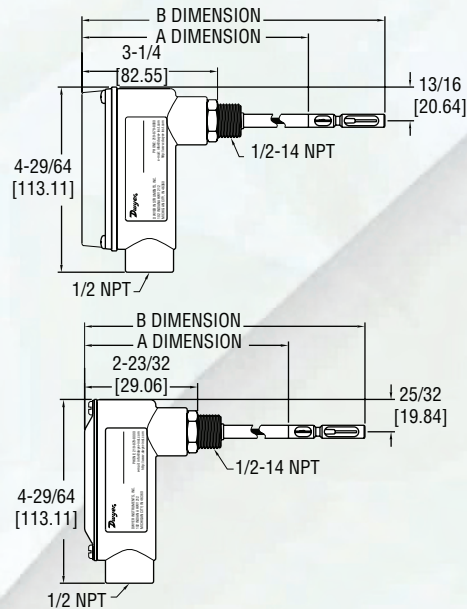

641 AVT WITH DISPLAY OPTION	
A DIMENSION	B DIMENSION
7-63/64 [202.80]	9-13/16 [249.24]
13-63/64 [355.20]	15-13/16 [401.64]
19-63/64 [507.60]	21-13/16 [554.04]
26-63/64 [685.40]	28-13/16 [731.84]
32-63/64 [837.80]	34-13/16 [884.24]
37-63/64 [964.80]	39-13/16 [1011.24]
641 AVT WITHOUT DISPLAY OPTION	
A DIMENSION	B DIMENSION
7-7/16 [188.91]	9-9/32 [235.74]
13-7/16 [341.31]	15-9/32 [388.14]
19-7/16 [493.71]	21-9/32 [540.54]
26-7/16 [671.51]	26-9/32 [718.34]
29-7/16 [747.71]	34-9/32 [870.74]
37-7/16 [950.91]	39-9/32 [997.74]

The new Series 641 Air Velocity Transmitter is the ideal instrument for monitoring air flow. This transmitter uses a heated mass flow sensor which allows for precise velocity measurements at various flow rates and temperatures. The 641's 16 field selectable ranges provides it the versatility to be selected for several air flow applications. The optional LED produces a complete, low-cost solution for local indication of air flow. The 641 is to be used with clean air only and is ideal for monitoring air flow after the air has passed through the filters.

FEATURES

- Ranges to 15,000 FPM or 75 MPS
- Optional Bright LED Display
- Easy Push Button Set-up
- Compact Housing
- 4-20 mA Output
- Digital Filter for Signal Damping

APPLICATIONS

- Exhaust Stack Flow Monitoring
- Air Velocity Measurements
- Fan Supply and Exhaust Tracking

Model Number	Probe Length*
641-6	6" (152.4 mm)
641-6-LED	6" (152.4 mm)
641-12	12" (304.8 mm)
641-12-LED	12" (304.8 mm)
641-18	18" (457.2 mm)
641-18-LED	18" (457.2 mm)
641-24	24" (609.6 mm)
641-24-LED	24" (609.6 mm)
641-30	30" (762 mm)
641-30-LED	30" (762 mm)
641-36	36" (914 mm)
641-36-LED	36" (914 mm)

*Other probe lengths available contact factory.

SPECIFICATIONS

Service: Clean air and compatible, non-combustible gases.

Accuracy:

3% FS Process gas: 32 to 122°F (0 to 50°C).

4% FS Process gas: -40 to 32°F & 122 to 212°F (-40 to 0°C & 50 to 100°C).

Response Time: Flow: 1.5 seconds to 95% of final value (Output filter set to minimum).

Temperature Limits: Process: -40 to 212°F (-40 to 100°C). Ambient: 32 to 140°F (0 to 60°C).

Pressure Limit: 100 psi (6.89 bar) maximum.

Humidity Limit: Non-Condensing.

Power Requirements: 12-35 VDC, 10-16 VAC.

Output Signal: 4-20 mA, isolated 24V source, 3 or 4-wire connection.

Output Filter: Selectable 0.5 -15 (seconds).

Loop Resistance: 600 ohms max.

Current Consumption: 300 mA max.

Electrical Connections: Screw terminal.

Process Connections: 1/2" male NPT.

Enclosure Rating: Designed to meet NEMA 4X (IP66) for non LED models only.

Mounting Orientation: Unit not position sensitive. Probe must be aligned with airflow.

Weight: 12.6 oz (357.2 g).

Agency Approval: CE.

OPTIONAL DISPLAY VERSION:

Display: 4-1/2 digit 1/2" red LED.

Resolution: 1 FPM, 0.01 MPS (10 FPM @ 10,000 and 15,000 FPM ranges).

Weight: 13.3 oz (377 g).

ACCESSORIES

A-156 Universal Mounting Plate 1/2" female NPT

No. A-158 Split Flange Mounting Kit

No. A-159 Duct Mounting Gland

Direct-Contact Speed Switch

Rugged Housing, Electronics and Mechanical Components in One Housing

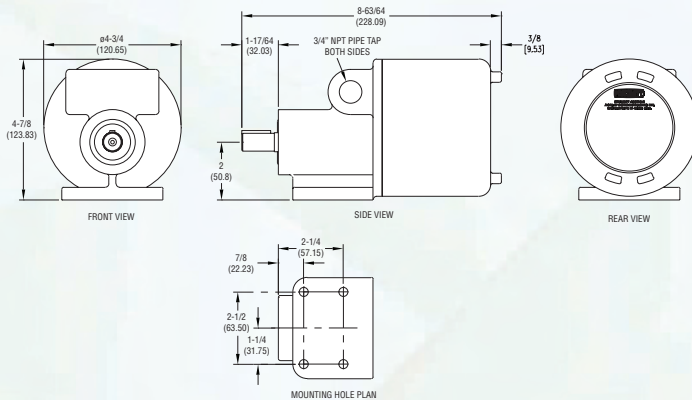
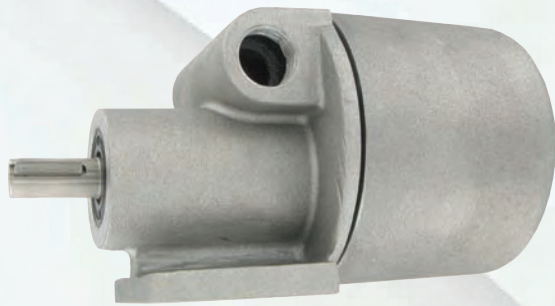

The Series DSS Direct-Contact Speed Switch is a compact switch designed to include all mechanical and electronic components in one housing. It will produce an output signal at a predetermined speed which may be either over-speed, under-speed or zero-speed. Rugged, heavy-duty construction combined with solid state electronics and photo-electric technology makes this one of the most advanced motion detectors available. Series DSS protects all valuable rotating equipment including belt conveyors, bucket elevators, rotary feeders or screw conveyors. It operates in a clockwise or counter-clockwise direction and mounts in any position.

Series DSS senses motion by means of a precision metal disc mounted on the input shaft. This disc generates measurable light pulses as a series of slots on its periphery rotate past an infra-red light source. A photo-electric sensor monitors the series of light pulses and converts them into a digital electronic signal. Solid state circuitry then analyzes the digital signal and activates or de-activates the output relay at the pre-set signal speed. It also features an adjustable built-in time delay eliminating the need for a separate start-up time delay relay.

The DSS will sense under-speed or over-speed conditions. Three signal speed ranges are available with each unit. The low signal speed range is from 0.1 to 10 RPM. The medium signal speed range is from 1 to 100 RPM, and the high speed range is 10 to 1000 RPM.

Field adjustment of the signal set point is easily accomplished by means of an adjustment screw. The signal speed ranges are selected by a three position toggle switch on the printed circuit board. For under-speed sensing, the signal point is set below the normal operating speed of the unit. The output relay will then de-energize if the speed drops below the signal set point. For over-speed sensing the signal set point is set above the normal operating speed. The output relay will energize if the speed exceeds the signal set point. The output relay can be wired either normally open or normally close.

Zero-speed sensing can be accomplished by locking the signal set point adjustment screw at its lowest setting of 0.1 RPM. The output relay will then de-energize when the shaft speed of the unit approaches zero.

SPECIFICATIONS

Temperature Limits: -50° to 150°F (-45° to 65°C).

Enclosure: Aluminum with screw cover.

Enclosure Rating: DSS-W: NEMA 3S, 4 & 4X. DSS-E: NEMA 3S, 4 & 4X, NEMA 7: Class I groups C & D, NEMA 9: Class II groups F & G.

Switch Type: DPDT.

Electrical Rating: 3A @ 120/240 VAC, 1/10 Hp @120/240 VAC.

Electrical Connections: Screw terminal.

Conduit Connections: (2) 3/4" female NPT.

Mounting Orientation: Any.

Set Point Adjustment: Adjustment screw.

Power Requirements: 105-135 VAC, 50/60 Hz, 210-250 VAC, 50/60 Hz; or 24 VAC/DC depending on model.

Power Consumption: 3 Watts.

Repeatability: 2% maximum at constant voltage and temperature.

Pick-up Point: 3 speed ranges at which relay will energize:

LOW: 0.1 to 10 RPM.

MEDIUM: 1 to 100 RPM.

HIGH: 10 to 1000 RPM.

Signal Point: Speed at which relay will de-energize. Recommended to be 15-20% lower than pick-up point.

Start-up Delay: Adjustable up to 45 seconds.

Radial Load on Input Shaft: 125 lbs maximum.

End Thrust on Input Shaft: 100 lbs maximum.

Rotation: Either clockwise or counter-clockwise.

Driving Torque: 17/lb maximum.

Shaft: 5/8" diameter with 3/16" x 7/8" key.

Weight: 5 lbs (2.3 kg).

Agency Approvals: UL.

Model No	Supply Voltage	Enclosure Rating	Enclosure Type
DSS-W1	120 VAC	Weatherproof	Aluminum
DSS-E1	120 VAC	Explosion-Proof	Aluminum
DSS-W2	240 VAC	Weatherproof	Aluminum
DSS-E2	240 VAC	Explosion-Proof	Aluminum
DSS-W3	24 VAC/DC	Weatherproof	Aluminum
DSS-E3	24 VAC/DC	Explosion-Proof	Aluminum

ACCESSORIES

Model No.	Description
A-426	Stub Shaft
A-427	Flexible Coupling
A-428	Coupling Guard
A-422	Mounting Bracket for DSS Switch

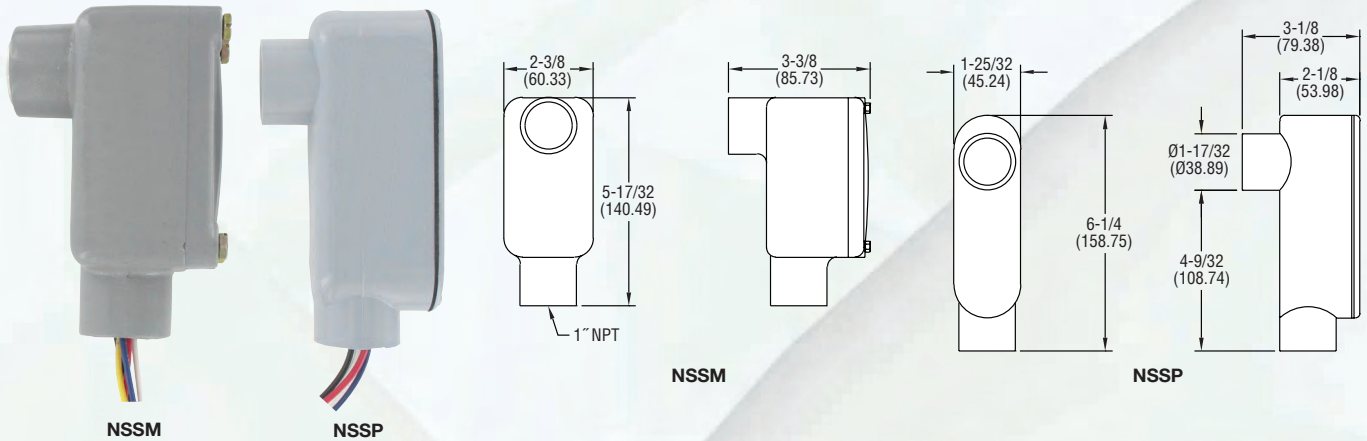

The **Series NSS** are self-contained rotation monitoring systems that are ideal for detecting the unwanted slowdown of process equipment. These systems bring efficiency and safety to your operations by preventing machine damage, product waste and costly downtime. The non-contact speed switch is commonly used to monitor drive trains, power-driven components, crushers, exhaust fans, screw conveyors, or tail pulleys on belt conveyors and elevators. The standard system includes either an NSSM-series or an NSSP-series switch and a pulsar DISC.

Miniature speed switches contain a sensor and switching electronics in either a heavy duty, explosion-proof cast aluminum housing (NSSM) or a chemical/corrosion resistant PVC housing (NSSP). Each switch is used with a shaft-end mounted pulsar DISC (or optional split collar pulsar wrap) which generates an alternating magnetic field that is picked up by the speed switch. The switch decodes this frequency signal to determine shaft speed and compares this to the pre-adjusted set point, easily calibrated via a single-turn potentiometer. In the event of rotational failure, such as a broken drive, belt slippage, product overloads or clogs, the relay can be used to provide an alarm or equipment shutdown, assuring machine protection and process integrity. The miniature speed switch series is fail-safe; any malfunction during operation will de-energize the control circuit.

The primary difference between the NSS-A and NSS-B is the set point range. The actual operating speed of the monitored shaft is not the critical factor when selecting which model to use, it is the desired set point speed at which the relay is to energize and de-energize. The NSS-A can be adjusted to trip from 10 to 100 rpm. The NSS-B can be adjusted to trip from 100 to 5,000 rpm.

SPECIFICATIONS

- Temperature Limits:** Operating -40 to 140 °F (-40 to 60 °C).
- Enclosure:** NSSP: Polyvinylchloride (PVC). NSSM: Cast Aluminum.
- Enclosure Rating:** NEMA 4X. NSSM: Class I, group D; Class II, groups E, F, G; Class III.
- Switch Type:** SPDT.
- Electrical Rating:** 5A @ 115 VAC.
- Electrical Connections:** 18 AWG, 12" (30.48 cm) long.
- Conduit Connections:** 1" female NPT.
- Power Requirements:** 115 VAC, 60 Hz standard.
- Input Signal Type:** NPN Open Collector.
- Set Point Adjustment:** Single turn (270°) Potentiometer.
- Gap Distance:** 3/8" ± 1/8".
- Weight:** NSSP-A1W: 0.54 lb (0.82 lb with disc).
NSSP-B1W: 0.54 lb (0.64 lb with disc).
NSSM-A1W: 1.58 lb (1.88 lb with disc).
NSSM-B1W: 1.60 lb (1.70 lb with disc).
- Agency Approval:** UL pending, CE.

FEATURES:

- Compact, self-contained system with sensor and switch
- Easy installation and calibration
- Rugged system is dust, dirt and grease-proof
- PVC corrosion-resistant NEMA 4X housing or Aluminum explosion-proof housing.
- Fail-safe operation

Model Number	Set Point Range	Supply Voltage	Enclosure	Disc Included
NSSP-A1W	10-100 RPM	115 VAC	Plastic	NONE
NSSP-B1W	100-5000 RPM	115 VAC	Plastic	NONE
NSSM-A1W	10-100 RPM	115 VAC	Metal	NONE
NSSM-AKIT	10-100 RPM	115 VAC	Metal	4" A DISC
NSSM-B1W	100-5,000 RPM	115 VAC	Metal	NONE
NSSM-BKIT	100-5,000 RPM	115 VAC	Metal	2-1/2" B DISC

Non-Contact Speed Switch Accessories

Easy Mount Brackets and Pulsar Discs



DISC A

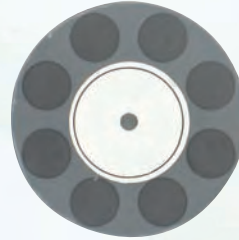

DISC B

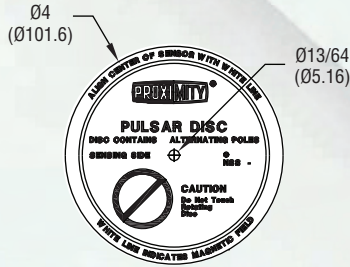

DISC A

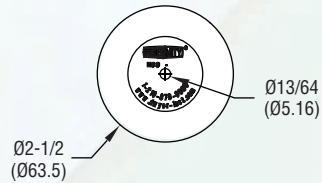

DISC B



A-290



A-291

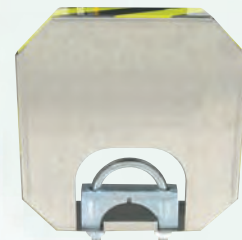

A-292

Easy Mount Brackets and Pulsar discs are add-on accessories for the NSS series non-contact speed switch. Pulsar discs are compatible with all sensors. Easy mount brackets make speed monitoring easier and more cost-effective.

SPECIFICATIONS

Wetted Materials: Pulsar discs: Nylon 12, PVC; Disc Guards: SS; Easy mount bracket: Aluminum with SS shaft.

Maximum Speed: 10,000 RPM at ambient temperature.

Temperature Limits: -40 to 140°F (-40 to 60°C) (PVC & Nylon); -40 to 302°F (-40 to 150°C) (SS & Aluminum).

Model Number	Description
DISCA	ø4" Pulsar disc, 16 magnetic poles for 10-100 RPM units
DISCB	ø2-1/2" Pulse disc, 8 magnetic poles for 100-5000 RPM units
A-290	Easy Mount Bracket assembly for NSSM includes 4" disc
A-291	Disc Guard for easy mount bracket, A-290
A-292	Disc Guard for NSS-AM/BM

Series
651

Temperature Transmitter

RTD or Thermocouple Input, Zero and Span Adjust, Linearized 4-20 mA Signal

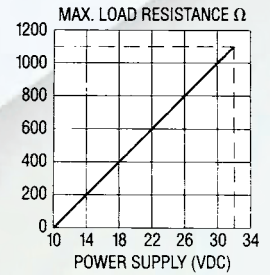
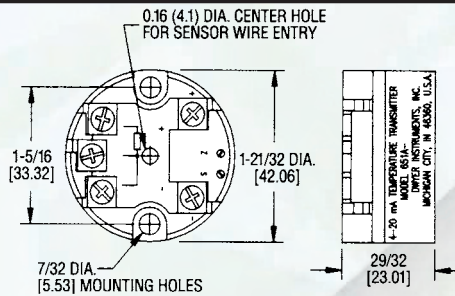

Linearized output for precise temperature monitoring or control is combined with small size and quick, easy mounting. Rugged Series 651 transmitters are designed for use with 2 or 3 wire Pt100 RTDs (to DIN standard 43760 or BS1904) or ungrounded Type K thermocouples. Thermocouple models 651TC are cold junction compensated, automatic 32 to 160°F (0 to 70°C) with upscale burnout. These economical devices provide the accuracy and reliability you need at the lowest possible cost. The 651 is excellent for remote monitoring of conveying air temperature in pneumatic conveying systems or material drying systems.

Model No.	Input Type	Range, °F (°C)
651A-10	Pt100 RTD	32-212 (0-100)
651A-20	Pt100 RTD	32-392 (0-200)
651A-40	Pt100 RTD	32-752 (0-400)
651TC-01	Type K Thermocouple	32-212 (0-100)
651TC-02	Type K Thermocouple	32-392 (0-200)
651TC-04	Type K Thermocouple	32-752 (0-400)
651TC-06	Type K Thermocouple	32-1112 (0-600)

SPECIFICATIONS

Input: 2 or 3 wire Pt100 RTD (models 651A), or ungrounded Type K thermocouple (models 651TC).

Output: 4-20 mA DC, linearized. **Transmitter Type:** 2-wire.

Output Impedance: 700Ω @ 24VDC.

Power Requirements: 10-32 VDC, reverse connection protected.

Accuracy: ±0.2°C plus 0.2% reading (models 651A), ±0.1% FS plus cold junction errors (models 651TC).

Temperature Drift: ZERO drift typical 0.02%/°C (0.09°F), SPAN typical 0.005%/°C (0.0036°F).

Ambient Operating Temperature: 32 to 122°F (0 to 50°C).

Maximum Storage Temperature: 160°F (70°C)

Response Time: 10-90% in 200 ms (models 651A), 70% in 2 ms (models 651TC).

Agency Approvals: CE.

ACCESSORY

A-709, Optional enclosure for Series 651 Transmitters. NEMA 1 protective housing is 3" x 2 1/8" (76 x 54 mm). Supplied with mounting hardware, strain relief fitting and assembly instructions.

Series
659

Push-Button Temperature Transmitter

Programmable, RTD, Thermistor or Thermocouple Input, In-Head Mounting

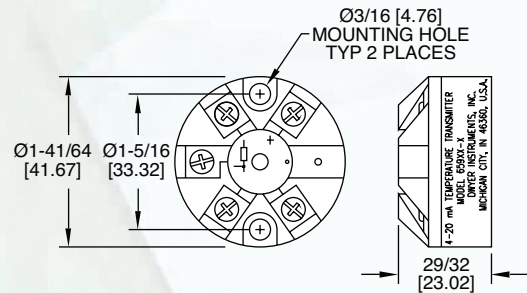

Series 659 Push-Button Temperature Transmitters accept thermocouple (J, K, T), RTD (Pt100Ω) or thermistor input and provide a linearized 4 to 20 mA output. The transmitter is quickly ranged and calibrated by using a single on-board switch. An LED provides visual indication of sensor fault and programming mode. Models feature reverse polarity protection. Thermocouple models are also galvanically isolated and cold junction compensated.

The compact transmitter can be mounted directly within any standard thermal head for connection to the sensor. The Series 659 is excellent for remote monitoring of conveying air temperature in pneumatic conveying systems or material drying systems.

Model Number	Input
659TC-1	Thermocouple (Type J, K, T)
659RTD-1	(3-wire RTD Pt100Ω)
659TH-1	Thermistor (2252Ω)

SPECIFICATIONS

Input Range: Type J T/C: -328 to 2192°F (-200 to 1200°C); Type K T/C: -328 to 2498°F (-200 to 1370°C); Type T T/C: -328 to 752°F (-200 to 400°C); Pt100Ω RTD: -328 to 1562°F (-200 to 850°C); Thermistor: -13 to 257°F.

Accuracy: T/C models: ±0.04% F.S., ±0.04% of reading or ±0.5°C whichever is greater; RTD: ±0.2°C ±0.1% of rdg; Thermistor: ±0.25°F (±0.1°C).

Output: Linearized 4 to 20 mA, 2-wire loop powered.

Sample Rate: 500 ms.

Loop Resistance: T/C: 700Ω @ 24 VDC; RTD: 800Ω @ 24VDC; Thermistor: 24 VDC.

Output Thermal Drift: Zero: 0.2µA/°C; Span: 0.5µA/°C.

Ambient Operating Temperature: -4 to 158°F (-20 to 70°C), 80% RH max.

Ambient Storage Temperature: -40 to 158°F (-40 to 70°C), 95% RH max.

Burnout: Upscale 22 mA.

Weight: 0.92 oz (26 g).

Series
RTD

Resistance Temperature Detector

High Temperature, Mineral Insulated, 316 SS Sheath

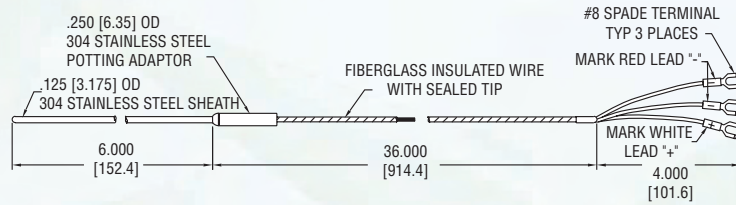
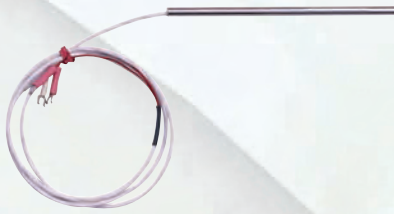

Precision RTD (Resistance Temperature Detector) offers excellent accuracy and stability over a wide temperature range. Industry standard 3-wire 100 ohm (DIN) probes are available in 6" (15 cm), 12" (30.5 cm), or 18" (46 cm) sheath lengths with 30" (76 cm) extension cable and spade lug terminals. Series RTD is perfect for use with 651 or 659 temperature transmitters.

SPECIFICATIONS

Sensor Type: Wire wound, 100 ohm.

Temperature Range: -328 to 1202°F (-200 to 650°C).

Pressure Limits: 250 psig.

Probe Material: 316 SS.

Extension Length: 30" (76 cm).

Standard: DIN .00385 (Class B, 0.12%).

Model Number	Length	Diameter
RTD-686	6" (15 cm)	1/8"
RTD-6812	12" (30.5 cm)	1/8"
RTD-6818	18" (46 cm)	1/8"
RTD-646	6" (15 cm)	1/4"
RTD-6412	12" (30.5 cm)	1/4"
RTD-6418	18" (46 cm)	1/4"

Series
BT

Bimetal Thermometers

2", 3" or 5" Dial, Dual Scale, ±1% FS Accuracy, External Reset

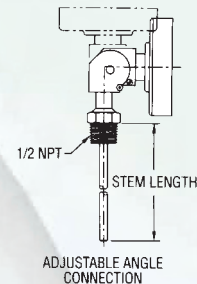
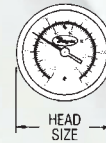
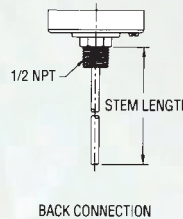

Series BT Bimetal Thermometers offer accurate, reliable service even in the toughest environments. These corrosion resistant units are constructed from stainless steel and are hermetically sealed to prevent crystal fogging. The bimetal element directly drives pointer, eliminating gears and linkage. An external reset screw allows field calibration and easy-to-read aluminum dial minimizes parallax error. Choose back connection, lower connection or adjustable angle for easy viewing and installation. Adjustable models can be rotated a full 360° and tilted over a 180° arc. The BT is ideal for local indication of conveying air temperature in pneumatic conveying systems or material drying systems. NOTE: When using in pressurized applications, use a suitable thermowell.

SPECIFICATIONS

Wetted Materials: 304 SS.

Accuracy: ±1% full scale.

Response Time: ≤ 40 seconds.

Temperature Limits: Head:

200°F (93°C). Stem: Not to exceed 50% over-range or 1000°F (538°C) or 800°F (427°C) continuously.

Process Connection: 1/4" NPT on 2" dial size; 1/2" NPT on 3" or 5" dial size.

Materials of Construction:

304 SS stem, glass crystal, anodized aluminum dial, Series 300 SS head, bezel, and mounting bushing.

Stem Diameter: 1/4" O.D.

Immersion Depth: Minimum 2" in liquids, 4" in gas.

Model Number	Dial Size, Stem Length	Temperature Range, °F(°C)	Degree Div., °F(°C)	Model Number	Dial Size, Stem Length	Temperature Range, °F(°C)	Degree Div., °F(°C)
Back Connection				Adjustable Angle Connection			
BTB22551*	2", 2-1/2"	0/250	2	BTA54010D	5", 4"	0/200 (-20/100)	2 (2)
BTB2405D	2", 4"	0/250 (-20/120)	2 (2)	BTA5405D	5", 4"	0/250 (-20/120)	2 (2)
BTB2409D	2", 4"	200/1000 (100/550)	10 (5)	BTA5407D	5", 4"	50/550 (10/290)	5 (5)
BTB32510D	3", 2 1/2"	0/200 (-20/100)	2 (2)	BTA56010D	5", 6"	0/200 (-20/100)	2 (2)
BTB3255D	3", 2 1/2"	0/250 (20/120)	2 (2)	BTA5605D	5", 6"	0/250 (-20/120)	2 (2)
BTB3257D	3", 2 1/2"	50/550 (10/290)	5 (5)	BTA5607D	5", 6"	50/550 (10/290)	5 (5)
BTB34010D	3", 4"	0/200 (-20/100)	2 (2)	Lower Connection			
BTB3405D	3", 4"	0/250 (-20/120)	2 (2)	BTC3255D	3", 2.5"	0/250 (-20/120)	2 (2)
BTB3407D	3", 4"	50/550 (10/290)	5 (5)				
BTB3605D	3", 6"	0/250 (-20/120)	2 (2)				

* Model offered in Fahrenheit Scale only.

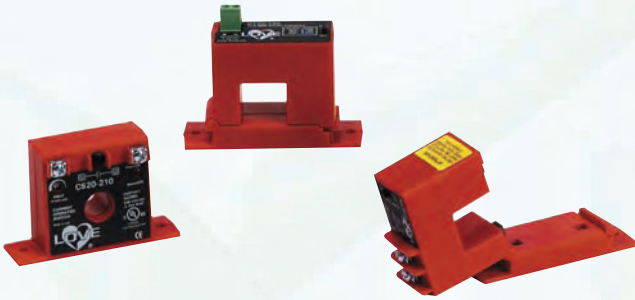

The CS Series Current Switches combine a current transformer, signal conditioner and limit alarm into a single package. The CS series has an extended current input range, universal solid-state outputs and a wide frequency response. Available in a split core or a solid core case. Switches feature LED indication for local display or switch status. The Series CS Current Switch monitors the operation of the air compressor in pneumatic conveying applications.

Model Number	Setpoint Range	Core	Voltage
CS20-100	Adj. 1.75-150 A	Split	240 VAC/DC
CS20-220	Adj. 1-150 A	Solid	240 VAC/DC
CS40-220	Selectable 1-6, 6-40, & 40-175A	Solid	240 VAC
CS50-100	Selectable 1-6, 6-40, & 40-175A	Split	240 VDC

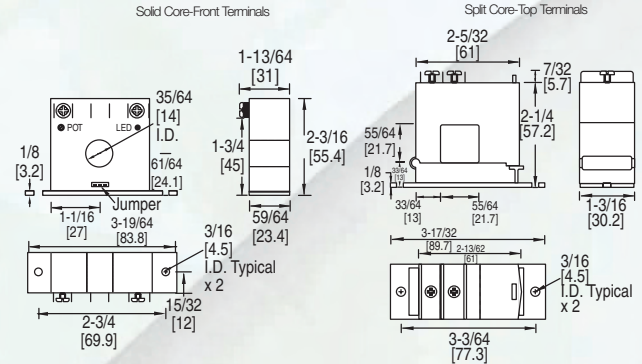

SPECIFICATIONS

- Output:** Isolated, normally open.
- Power Requirements:** None, self powered.
- Temperature Limits:** -58 to 149°F (-50 to 65°C).
- Hysteresis:** 5% of output.
- Response Time:** CS20: 0.120 sec; CS40/50: 0.04 to .120 sec.
- Isolation Voltage:** 1270 VAC.
- Frequency:** 6-100 Hz.
- Enclosure Rating:** UL, V-O flammability rated, ABS plastic housing.
- Agency Approvals:** CE.

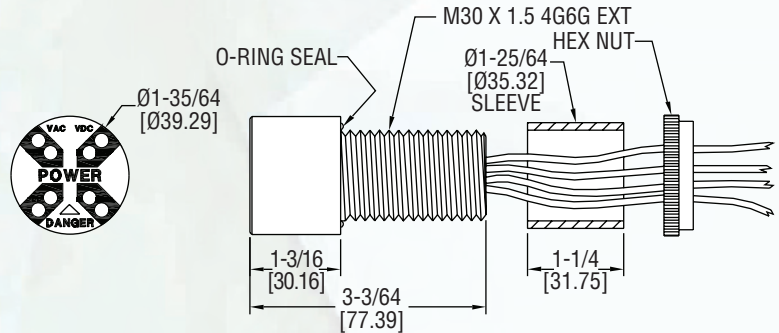

The Series UPA-130 Power Alert reduces the risk of electrical arc flash by pre-verifying the electrical isolation from the outside of a control panel. The Universal Power Alert is hardwired to the circuit breaker or main disconnect and has an LED indication whenever voltage is present. It is engineered with redundant circuitry, which allows it to be powered by the same voltage that it indicates. The eight detector UPA-130 visually alerts to the presence of any dangerous AC or DC (stored energy) potentials occurring between any combination of the four input lines (L1, L2, L3, GND). The UPA-130 Universal Power Alert is designed to fit a 30mm knockout.

SPECIFICATIONS

- Operational Range:** AC Single or 3-Phase: 40 to 750 VAC 50/60/400 Hz, (Line-To-Line or Line-To-GND [UL approved 50/60 Hz]). DC or Stored Energy: 30 to 1000 VDC, (Line-To-Line or Line-To-GND).
- Maximum Rated Voltage:** 750 VAC/1000 VDC (Line-To-Line or Line-To-GND).
- Detection Thresholds:** 29 VAC 3-Phase, 40 VAC SINGLE-Phase, 27 VDC (TYP CUTOFF).
- Power Consumption:** 1.2 Watts at 750 VAC.
- Temperature Rating:** Operate: -4 to 131°F (-20 to 55°C) Storage: -40 to 185°F (-40 to 85°C).
- Enclosure:** Totally Encapsulated for Environment Protection. NEMA 4X (IP66).
- Electrical Connections:** (4) 6 ft, 18 AWG 1000V, UL-1452.
- Weight:** 7 oz (198.45 g).
- Agency Approvals:** UL.

Temperature/Power

Diaphragm Valves For Reverse Jet Pulse Dust Collection



FEATURES

- Fast Opening Design for Max Flow
- Industrial Construction and Design
- Available with Integrated or Remote Solenoids
- Pilot Valves Available in Weatherproof Enclosures
- Replacement Diaphragms Available

APPLICATIONS

- Bin Vents
- Bag Houses
- Cartridge Filters
- Down Draft Tables

Operating Principle

The valve is divided into two chambers by a diaphragm. These upper and lower chambers are connected by a small air passage so both chambers see the same pressure. When the exhaust is closed air cannot vent out of the upper chamber and the valve stays closed as shown in Figure 1. When the exhaust on the upper chamber is opened the air pressure decreases on the top of the diaphragm allowing the air pressure on the bottom to force open the valve by pushing the diaphragm up as shown in Figure 2. When the valve opens an abrupt air blast comes through the valve outlet and is directed by the dust collector to the dirty filter. The air pulse then blows out through the filter from the inside blowing the particulate accumulation off of the filter to clean it. After the air pulse the pressure in the upper and lower chamber will equalize and the spring pushes the valve back to a closed position. The valve exhaust port is controlled by either an integral or remote solenoid.

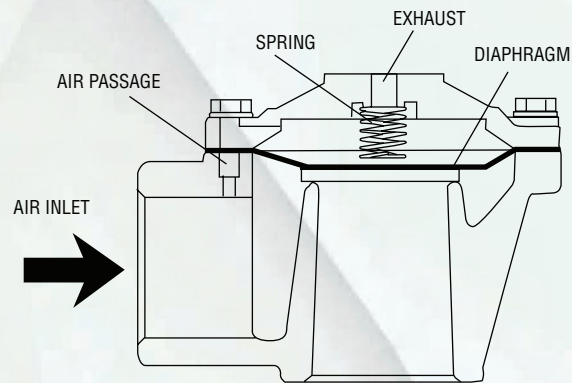

Figure 1. Closed Position

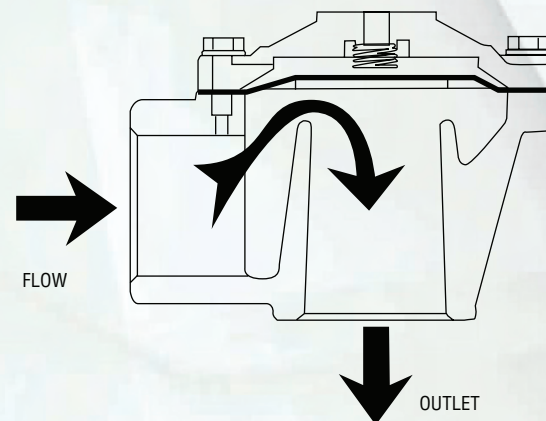

Figure 2. Open Position



DCV62T1D



DCV20C1D



RDCV62T



RDCV20C

The Series DCV/RDCV Dust Collection Valves are ideal for use with the Series DCT1000 and Series DCT500 duct collection timer boards for controlling the air pulse in jet pulse type dust collectors to clean the filters. Both the Series DCV and RDCV have the option for either coupling or NPT connections. The coupling connection allows for a quick and simple installation. Only the stub pipe and blowtube need to be cleaned and deburred before the valve is fit into position. The “T” Series DCV has female threaded connections. Both the “C” and “T” versions have a 90° angle between the inlet and outlet the most suitable configuration for pulse valve applications. The design offers not only ease of installation, but also minimal airflow restriction for an exceptional cleaning pulse. The valves are offered in both integrated and remote coil configurations.

SPECIFICATIONS

Service: Compatible gases, filtered and oil free.

Wetted Materials: Body: aluminum; Trim: 304 SS; Diaphragm and seals: NBR; Diaphragm disc: polyamide.

Other Materials: Cover: aluminum; Body bolts and spring: 304 SS.

Pressure Limits: Minimum of 4.4 psi (0.3 bar), maximum of 124.7 psi (8.6 bar).

Temperature Limits: Ambient: -4 to 140°F (-20 to 60°C) for RDCV models, -4 to 122°F (-20 to 50°C) for DCV models; Operating: -4 to 185°F (-20 to 85°C).

Power Requirements: 110 VAC, 220 VAC, or 24 VDC for DCV models.

Power Consumption: 12 W, inrush: 17 VA; holding: 14.5 VA for DCV models.

Electrical Connection: DIN connection for DCV models.

Enclosure Rating: NEMA 4X (IP65) for DCV models.

Process Connection: See model chart.

Mounting Orientation: Any position.

Agency Approvals: CE.

Model Number	Size	Solenoid	Connection	Number of Diaphragms	Cv Factor (gal/min)
RDCV20T	3/4"	Remote	NPT	1	14
RDCV20C		Remote	Coupling		
DCV20T1D		Integral*	NPT		
DCV20C1D		Integral*	Coupling		
RDCV25T	1"	Remote	NPT	1	23
RDCV25C		Remote	Coupling		
DCV25T1D		Integral*	NPT		
DCV25C1D		Integral*	Coupling		
RDCV35T	1-1/2"	Remote	NPT	1	42
RDCV35C		Remote	Coupling		
DCV35T1D		Integral*	NPT		
DCV35C1D		Integral*	Coupling		
RDCV45T	1-1/2"	Remote	NPT	2	51
RDCV45C		Remote	Coupling		
DCV45T1D		Integral*	NPT		
DCV45C1D		Integral*	Coupling		
RDCV50T	2"	Remote	NPT	2	106
DCV50T1D		Integral*	NPT		
RDCV62T	2-1/2"	Remote	NPT	2	136
DCV62T1D		Integral*	NPT		
RDCV76T	3"	Remote	NPT	2	167
DCV76T1D		Integral*	NPT		

* 110 VAC with DIN Connector.

Series DCV/RDCV Model Guide

Construction	DCV	RDCV				Integrated Coil	Remote Coil
Size			20			3/4"	
			25			1"	
			35			1-1/2"	
			45			1-1/2" (2 Diaphragms)	
			50			2"	
			62			2-1/2"	
Connection				T		NPT	
				C		Coupling (up to 1-1/2" only)	
Voltage					1	110 VAC (for integrated coil only)	
					2	220 VAC (for integrated coil only)	
					3	24 VDC (for integrated coil only)	
Electrical Connections						D	DIN (for integrated coil only)

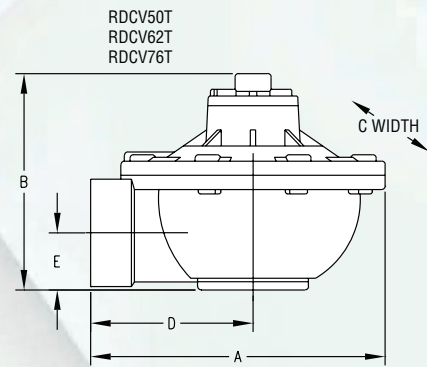
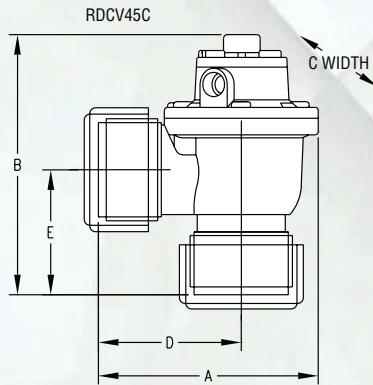
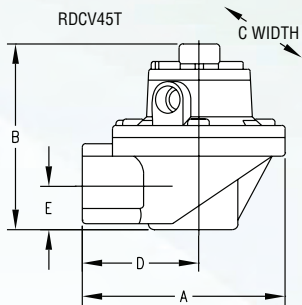
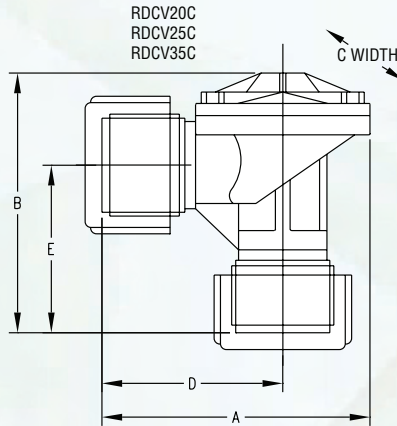
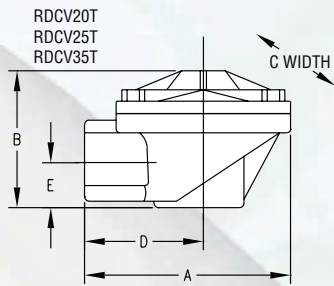

DIMENSIONAL CHART

Connection	Model Number	A (mm)	B (mm)	C (mm)	D (mm)	E (mm)	Weight lb (kg)
NPT	RDCV20T	3-15/16" (100)	2-31/32" (75)	3-7/16" (87)	2-3/16" (56)	25/32" (20)	1.12 (.51)
	RDCV25T	4-1/8" (105)	3" (76)	3-1/4" (83)	2-1/2" (64)	7/8" (22)	1.15 (.52)
	RDCV35T	5-1/8" (130)	4-29/32" (125)	4-3/8" (111)	4-1/2" (114)	1-9/32" (33)	2.0 (.91)
	RDCV45T	5-25/32" (147)	5-5/32" (131)	4-3/8" (111)	3-5/8" (91)	3" (76)	2.2 (1.0)
	RDCV50T	8-1/16" (205)	5-7/8" (149)	7-1/4" (184)	4-15/32" (113)	1-9/16" (40)	4.2 (1.9)
	RDCV62T	8-9/32" (210)	6-11/16" (170)	7-1/4" (184)	4-21/32" (118)	1-29/32" (48)	5.5 (2.5)
	RDCV76T	8-19/32" (218)	7-27/32" (199)	7-7/8" (200)	4-21/32" (118)	2-1/2" (63)	6.6 (3.0)
Coupling	RDCV20C	4-13/32" (112)	4" (102)	3-7/16" (87)	2-5/8" (67)	1-25/32" (45)	1.37 (.62)
	RDCV25C	4-5/8" (117)	5" (127)	3-1/4" (83)	3" (76)	2-3/4" (70)	2.1 (.96)
	RDCV35C	5-13/16" (147)	5-15/32" (139)	4-3/8" (111)	3-5/8" (91)	3" (76)	2.4 (1.1)
	RDCV45C	5-25/32" (147)	6-25/32" (172)	4-3/8" (111)	3-5/8" (91)	3" (76)	3.2 (1.45)

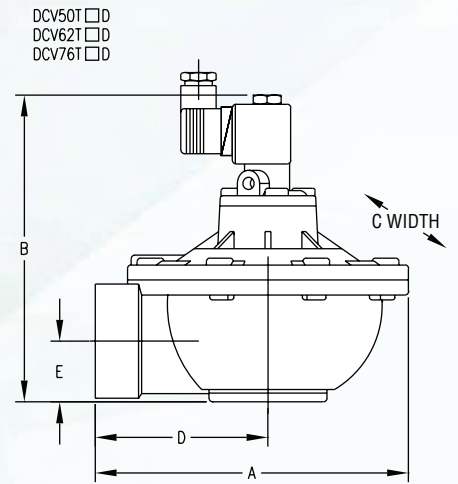
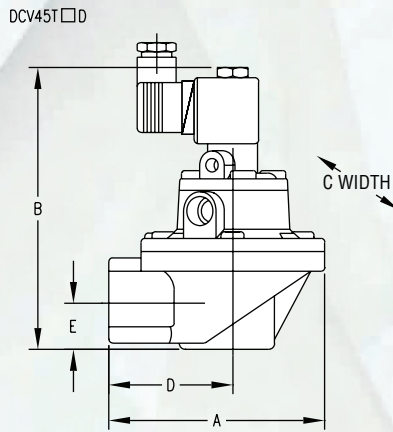
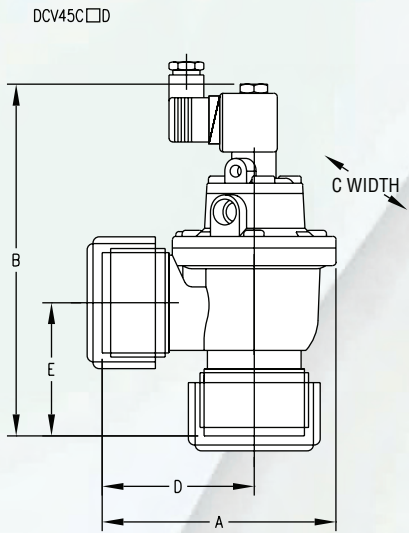
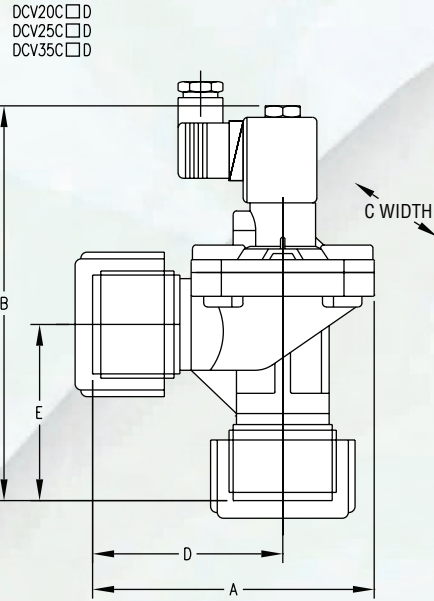
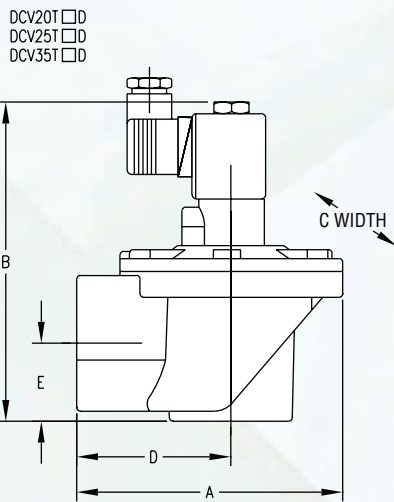

DIMENSIONAL CHART

Connection	Model Number	A (mm)	B (mm)	C (mm)	D (mm)	E (mm)	Weight lb (kg)
NPT	DCV20T_D	3-15/16" (100)	4-13/16" (122)	3-7/16" (87)	2-3/16" (56)	25/32" (20)	1.31 (.59)
	DCV25T_D	4-1/8" (105)	4-21/32" (126)	3-1/4" (83)	2-1/2" (64)	7/8" (22)	1.33 (.60)
	DCV35T_D	5-1/8" (130)	6-1/16" (154)	4-3/8" (111)	4-1/2" (114)	1-9/32" (33)	2.2 (.99)
	DCV45T_D	5-25/32" (147)	7-7/32" (183)	4-3/8" (111)	3-5/8" (91)	3" (76)	2.4 (1.1)
	DCV50T_D	8-1/16" (205)	7-29/32" (201)	7-1/4" (184)	4-15/32" (113)	1-9/16" (40)	4.4 (2.0)
	DCV62T_D	8-9/32" (210)	8-3/4" (222)	7-1/4" (184)	4-21/32" (118)	1-29/32" (48)	5.7 (2.6)
	DCV76T_D	8-19/32" (218)	9-7/8" (251)	7-7/8" (200)	4-21/32" (118)	2-1/2" (63)	6.8 (3.1)
	DCV45C_D	5-25/32" (147)	8-27/32" (224)	4-3/8" (111)	3-5/8" (91)	3" (76)	3.4 (1.5)
Coupling	DCV20C_D	4-13/32" (112)	5-27/32" (148)	3-7/16" (87)	2-5/8" (67)	1-25/32" (45)	1.55 (.70)
	DCV25C_D	4-5/8" (117)	6-21/32" (177)	3-1/4" (83)	3" (76)	2-3/4" (70)	2.3 (1.0)
	DCV35C_D	5-13/16" (147)	7-21/32" (194)	4-3/8" (111)	3-5/8" (91)	3" (76)	2.6 (1.2)
	DCV45C_D	5-25/32" (147)	8-27/32" (224)	4-3/8" (111)	3-5/8" (91)	3" (76)	3.4 (1.5)
	DCV50C_D	8-1/16" (205)	7-29/32" (201)	7-1/4" (184)	4-15/32" (113)	1-9/16" (40)	4.4 (2.0)

For Use with Remote Valves

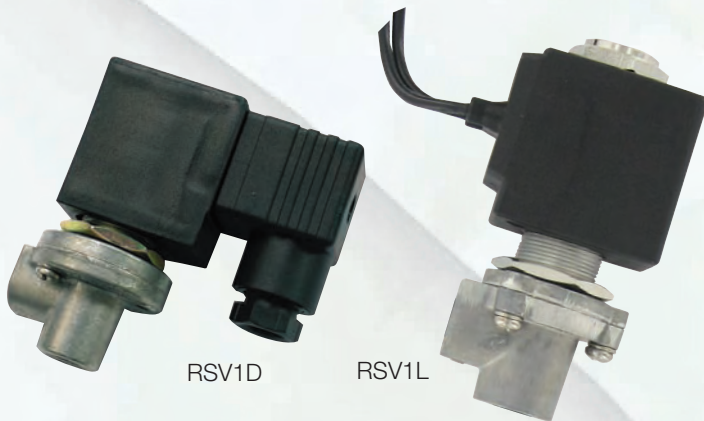

RSV1D

RSV1L

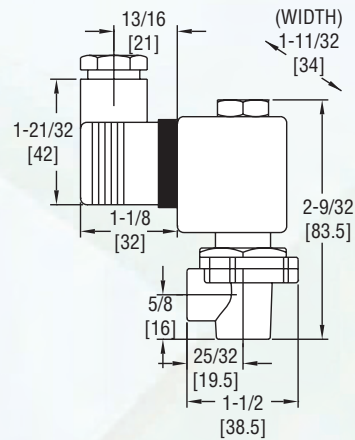

The Series RSV Pilot Solenoid Valve is used to operate the Series RDCV remote type diaphragm valve to air pulse clean filters in dust collectors. Series RDCV does not include an integral solenoid and needs to be activated remotely. The RSV can drive all size diaphragm valves. The units can be bought separately for mounting in a panel or can be purchased mounted on our SVE enclosure. Consult factory for mounting of RSV valves with our DCT timer boards together in one enclosure all pre-wired.

SPECIFICATIONS

- Service:** Compatible gases, filtered and oil free.
- Wetted Materials:** Body: aluminum; Core and spring: 304 SS; Seals: NBR.
- Pressure Limits:** Minimum of 4.4 psi (0.3 bar), maximum of 124.7 psi (8.6 bar).
- Temperature Limits:** Ambient: -4 to 122°F (-20 to 50°C); Operating: -4 to 185°F (-20 to 85°C).
- Power Requirements:** 110 VAC, 220 VAC, or 24 VDC.
- Power Consumption:** 12 W, inrush: 17 VA, holding: 14.5 VA.
- Enclosure Rating:** NEMA 4X (IP65).
- Electrical Connection:** DIN connection or wire leads, 18 AWG, 22" (55 cm) long.
- Process Connection:** 1/8" female NPT.
- Mounting Orientation:** Any position.
- Weight:** 0.60 lb (0.27 kg).
- Pneumatic Tube Length:** Maximum of 9.8 ft (3 m).
- Agency Approvals:** CE.

Model Number	Voltage	Electrical Connections	Cv
RSV1D	110 VAC	DIN	.33
RSV2D	220 VAC	DIN	.33
RSV3D	24 VDC	DIN	.33
RSV1L	110 VAC	Wire Leads	.33
RSV2L	220 VAC	Wire Leads	.33
RSV3L	24 VDC	Wire Leads	.33

Muffler Accessory

For Pulse Valve Exhaust

A-238

A-237

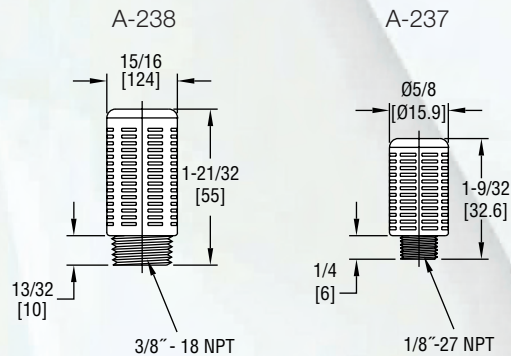

The Muffler Accessory can be easily field installed to any diaphragm valve with an exhaust. Pneumatic exhaust ports are on the diaphragm valves that have dual diaphragms and the units with the integral mounted solenoid. The muffler decreases the amount of noise when the air is exhausted from the valve. Valves with dual diaphragms and an integral solenoid have two exhaust ports and will require one A-237 and one A-238.

SPECIFICATIONS

- Material:** Polypropylene.
- Pressure Limits:** 130.5 psi (9 bar).
- Temperature Limits:** Ambient: -4 to 140°F (-20 to 60°C); Operating: -4 to 185°F (-20 to 85°C).

Model Number	Description	Fits Valve Sizes
A-237	1/8" NPT	3/4", 1", 1-1/2", RSV
A-238	3/8" NPT	1-1/2", 2", 1-1/2", 3"

Solenoid Valve Enclosure

For the Series RSV Remote Solenoid Valves

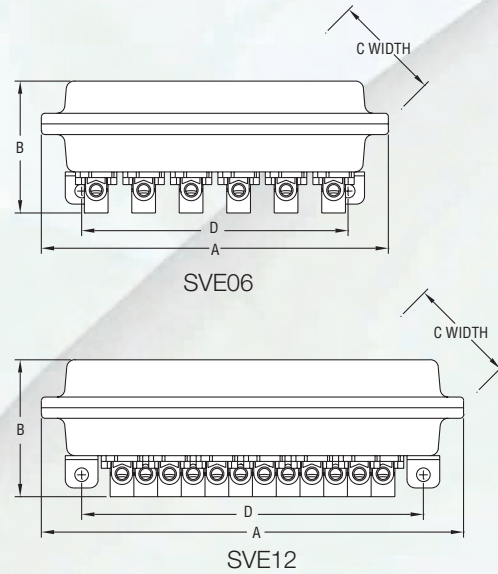

Model Number	A (mm)	B (mm)	C (mm)	D (mm)
SVE06	10-5/8" (270)	4-11/64" (106)	6-5/16" (160)	9-7/32" (234)
SVE12	18-29/32" (480)	4-11/64" (106)	6-5/16" (160)	17-9/16" (446)

The Series SVE are multi-valve enclosures for the RSV pilot valve. The SVE offers a convenient weatherproof enclosure package with all solenoids pre-wired to a terminal block. Enclosures are available in 6 or 12 valve size with choice of pilot valve voltage.

SPECIFICATIONS

Service: (For RSV) Compatible gases, filtered and oil free.

Wetted Materials: (For RSV) Body: aluminum; Core and spring: 304 SS; Seals: NBR.

Pressure Limits: (For RSV) Minimum of 4.4 psi (0.3 bar), maximum of 124.7 psi (8.6 bar).

Temperature Limits: Ambient: -4 to 122°F (-20 to 50°C); Operating: -4 to 185°F (-20 to 85°C).

Power Requirement: (For RSV) 110 VAC, 220 VAC, or 24 VDC.

Power Consumption: (For RSV) 12 W, inrush: 17 VA, holding: 14.5 VA.

Enclosure Rating: NEMA 4X (IP65).

Enclosure Material: Anodized aluminum with NBR gasket.

Electrical Connection: All RSV are pre-wired to a terminal strip.

Process Connection: (For RSV) 1/8" female NPT. (Consult factory for 1/4" NPT).

Conduit Connection: 3/4" female NPT.

Mounting Orientation: Any position.

Pneumatic Tube Length: Maximum of 9.8 ft (3 m).

Series SVE Enclosure Model Guide

Solenoid Valve Enclosure	SVE			Enclosure for solenoid valves
Valve Enclosure Size	06			6 solenoid channels
	12			12 solenoid channels
Enclosure Type		WP		Weatherproof enclosure
Solenoids Fitted			02	2 Solenoids fitted
			03	3 Solenoids fitted
			04	4 Solenoids fitted
			05	5 Solenoids fitted
			06	6 Solenoids fitted
			07	7 Solenoids fitted
			08	8 Solenoids fitted
			09	9 Solenoids fitted
			10	10 Solenoids fitted
			11	11 Solenoids fitted
			12	12 Solenoids fitted
Voltage			1	110 VAC
			2	220 VAC
			3	24 VDC

Note: Maximum quantity of pre-fitted solenoids can not exceed the underlined number.

Model Number	Quantity of Solenoid	Enclosure Type	Voltage
SVE06WP61	6	Weatherproof	110 VAC
SVE06WP62	6	Weatherproof	220 VAC
SVE06WP63	6	Weatherproof	24 VDC
SVE12WP121	12	Weatherproof	110 VAC
SVE12WP122	12	Weatherproof	220 VAC
SVE12WP123	12	Weatherproof	24 VDC

Dust Collector Timer and Valve Package



DCT500 - NEMA 4X
for RSV



DCT500 - NEMA 4/4X
Weatherproof Enclosure

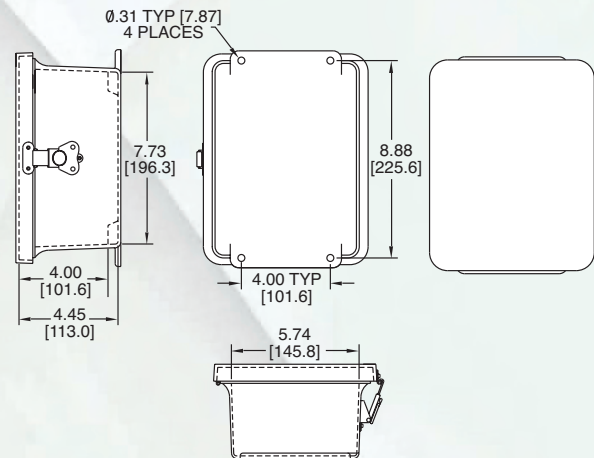

Dwyer Instruments, Inc. offers the convenient packaging of our DCT Series timer boards and RSV solenoid pilot valves in one weatherproof enclosure. Everything is ready for installation directly to the dust collector in one enclosure. The RSV valves come pre-wired to the DCT timer board so only the board has to be connected to the power supply. Series RSV valves are mounted through the wall of the enclosure for easy external access to the pressure connectors and have a weatherproof gasket to maintain the weatherproof integrity of the enclosure. Packages are custom made to your specifications; contact the factory for price and delivery information. See page 12 for more information on the available weatherproof enclosures.

ADVANTAGES

- Valves are pre-wired to the board reducing installation time.
- One simple weatherproof package to install on the dust collector.
- Do not need two enclosures – one for the valves and one for the timer board lowering system cost.

Series
BHC

Bulk Head Connector

Coupling Accessories



BHC35DD



BHC35D

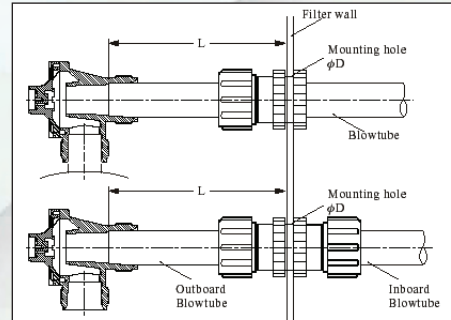
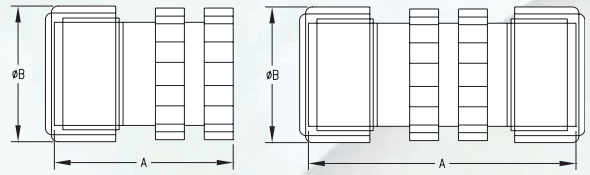

Series BHC Bulk Head Connectors allow for easy installation of blow tube through the dust collector wall and eliminate the need for welding or use of additional flanges. The fittings enable easy removal and reassembly of blow tubes for cleaning and maintenance. BHC models are available in single connection for through tube mounting or double connection for two piece tube mounting.

Model Number	Size	Connections
BHC20D	3/4"	One
BHC20DD	3/4"	Two
BHC25D	1"	One
BHC25DD	1"	Two
BHC35D	1-1/2"	One
BHC35DD	1-1/2"	Two

Model Number	A in (mm)	B in (mm)	D in (mm)	Min L in (mm)
BHC20D	2-3/8" (60.5)	2-5/16" (58.5)	1-25/32" to 2"	3-27/32" (97)
BHC20DD	3-19/32" (91)	2-5/16" (58.5)	(45 to 51)	
BHC25D	2-23/32" (69)	2-3/4" (70)	2-7/32" to 2-7/16"	4-21/32" (118)
BHC25DD	3-31/32" (101)	2-3/4" (70)	(56 to 62)	
BHC35D	2-15/16" (75)	3-15/32" (88)	2-27/32" to 3-1/16"	6-3/16" (157)
BHC35DD	4-11/32" (110)	3-15/32" (88)	(72 to 78)	

SPECIFICATIONS

Service: Compatible gases.

Wetted Material: Body, Ring nut, DIN nut: aluminum; Washer: SS41; Gasket: NBR.

Pressure Limits: 124.7 psi (8.6 bar).

Temperature Limits: -4 to 185°F (-20 to 85°C).

Series
DCD

Repair Kit

Diaphragm Replacements for Series DCV/RDCV

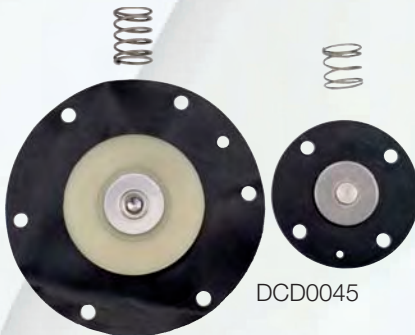

DCD0045



DCD0035



DCD0020

Series DCD are replacement diaphragm kits for the Series DCV/RDCV valves. This kit includes the standard wearing parts of the valve for field replacement.

SPECIFICATIONS

Materials: Diaphragm: NBR; Disc: polyamide; Spring: 304 SS.

Model Number	Diaphragm Valve Size	Model Number	Diaphragm Valve Size
DCD0020	3/4"	DCD0050	2"
DCD0025	1"	DCD0062	2-1/2"
DCD0035	1-1/2"	DCD0076	3"
DCD0045	1-1/2" (Dual)		

Note: All model numbers include the necessary quantity of replacement diaphragms along with the spring.

Series
BV2MB

Two-Piece Hand Lever Brass Ball Valve

Full Port, Economical, Blowout-Proof Stem

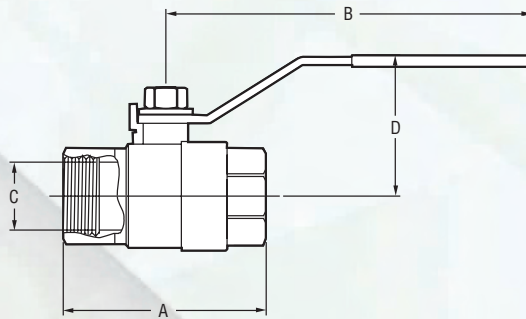

DIMENSIONS (inches)

Size	A (Ref)	B (Ref)	C (Ref)	D (Ref)
1/4"	1.800	3.800	.393	1.250
3/8"	2.000	3.800	.393	1.250
1/2"	2.070	3.800	.551	1.830
3/4"	2.360	3.800	.748	1.950
1"	2.950	4.350	.944	2.170
1-1/4"	3.370	5.470	1.181	2.800
1-1/2"	3.740	5.470	1.496	3.030
2"	4.290	6.380	1.850	3.330
2-1/2"	5.650	8.720	2.440	4.000
3"	6.180	8.720	2.990	4.310

The Series BV2MB is an economical hand lever ball valve for commercial and general industrial use. The Series BV2MB is perfect for compressed air applications in dust collectors and pneumatic conveying systems. Valve body, body cap, and ball are made of quality brass. Seats and stem packing are constructed of TFE for long lasting service. Blowout-proof stem provides safety in the event of overpressure. Full port design allows for maximum Cv and minimal pressure drop.

Size	Model	Cv	Size	Model	Cv
1/4"	BV2MB00	7.5	1-1/4"	BV2MB05	105
3/8"	BV2MB01	7.5	1-1/2"	BV2MB06	160
1/2"	BV2MB02	16	2"	BV2MB07	325
3/4"	BV2MB03	43	2-1/2"	BV2MB08	475
1"	BV2MB04	58	3"	BV2MB09	780

SPECIFICATIONS

Body: Two-Piece.

End Connections: 1/4" to 3" female NPT.

Pressure Limit: 1/4" to 1": 600 psi (41.4 bar), 1-1/4" to 2": 400 psi (27.6 bar), 2-1/2" to 3": 200 psi (13.8 bar) WOG.

Wetted Materials: Body and body cap: forged brass (ASTM B283-C37700); ball and stem: brass; seat and packing: TFE.

Temperature Limit: 10 to 200°F (-12 to 93°C).

Other Materials: Body seal: rubber; handle: plated steel; nut and gasket: brass.

Series
DV

Timed Automatic Drain Valve

Motorized Ball Valve with Adjustable Digital Timer

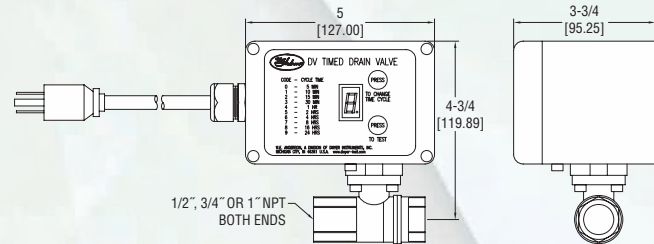

Series DV is an automatic drain system designed to eliminate the need to manually drain water and harmful sediments from your compressed air system, thereby improving the systems performance. The unit can be used on receivers, dryers, tanks, and drop legs for sampling and purging a wide variety of liquids. The Series DV has a heavy-duty motor for operation under adverse conditions and an adjustable timer to meet specific user requirements. By design, the Series DV eliminates major drawbacks of other compressed air draining systems. The valve is brass for corrosion resistance and it is a full port ball valve giving maximum and unobstructed flow with no clogging. A test button allows for the unit to be cycled at any time. It is mountable in any position for easy plumbing and trouble free operation.

Model Number	Size
DV02	1/4" and 1/2"
DV03	3/4"
DV04	1"

*Standard is 1/2" with 1/4" bushing.

SPECIFICATIONS

Body: 2 - piece.

Line Size: 1/4" to 1".

End Connections: Female NPT.

Pressure Limit: 200 psi (13.8 bar).

Wetted Materials: Body, End Cap: Forged Brass Ball; Stem: Chrome Plated Brass; Seat: RTFE; Stem Seal: Fluoroelastomer; Bushings: Brass.

Temperature Limits: 35 to 165°F (2 to 74°C).

Other Materials: Thrust washer: RTFE; Fasteners: Stainless Steel.

Discharge Time: 3.5 seconds non-adjustable.

Discharge Volume Cycle: 1/2":

0.92 gal @ 80 psi (valve only);
3/4": 1.64 gal @ 80 psi; 1": 2.50 gal @ 80 psi.

ACTUATOR

Electric

Power Requirements: 110 VAC, 60 Hz, single phase.

Power Consumption: 2.5 A.

Cycle Time Adjustable: 5 min, 10 min, 15 min, 30 min, 1 hr, 2 hr, 4 hr, 8 hr, 16 hr, 24 hr.

Enclosure Rating: NEMA 4.

Housing Material:

Polycarbonate.

Electrical Connection: 18

AWGX3C, 8 ft (24 m) power cord.

Series
ABV

Automated Two-Piece Brass Ball Valves

Compressed Air Shut-off Valve



Electric Actuator



Pneumatic Actuator

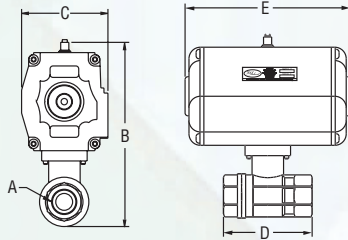
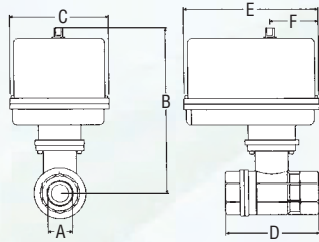

ABV Series Automated Ball Valves

- Full port brass ball valve
- Direct mount actuators for compact assembly
- Electric actuator that is rated NEMA 4 and is available in two position or modulating
- Pneumatic double acting or spring return rack and pinion actuator

Series ABV incorporates a full port brass ball valve for great flow rates with minimal pressure drop. The valve features a blowout proof stem for added safety, reinforced TFE seats and seals for longer life, and a Chrome/Nickel plated ball for better performance. Actuators are direct mounted creating a compact assembly for tight spaces. Double o-ring stem seals assure leak free operation.

The ABV Series is an economical automated valve package with either an electric or pneumatic actuator. Electric actuated models are weatherproof, NEMA 4, powered by standard 115 VAC supply, and are available in either two-position or proportional control. Two-position actuators use the 115 VAC input to drive the valve open or closed, while the modulating actuator accepts a 4 to 20 mA input for infinite valve positioning. Actuator features thermal overload protection and a permanently lubricated gear train.

The pneumatic double acting actuator uses an air supply to drive the valve open and closed. The actuator has two supply ports with one driving the valve open and the other driving the valve closed. Spring return pneumatic actuator uses the air supply to open the valve and internally loaded springs return the valve to the closed position. Also available is the SV3 solenoid valve to electrically switch the air supply pressure between the air supply ports for opening and closing the valve. Actuators are constructed of anodized and epoxy coated aluminum for years of corrosion free service. Series ABV is ideal to use as an automated on/off valve on the compressed air lines for pneumatic conveying systems or pulse jet dust collectors.

ELECTRIC								
	1/2"	3/4"	1"	1-1/4"	1-1/2"	2"	2-1/2"	3"
A	6.130	6.199	6.574	6.700	8.291	8.623	9.177	9.611
B	4.000	4.000	4.000	4.000	4.215	4.215	4.215	4.215
C	2.638	2.980	3.350	3.657	4.126	4.805	6.496	7.402
D	5.630	5.630	5.630	5.630	5.630	6.880	6.880	6.880
E	2.310	2.310	2.310	2.310	2.430	2.430	2.430	2.430

PNEUMATIC DOUBLE ACTING											
	1/4"	3/8"	1/2"	3/4"	1"	1-1/4"	1-1/2"	2"	2-1/2"	3"	4"
A	4.200	4.200	4.200	4.269	4.644	4.770	6.226	6.558	7.552	7.986	9.801
B	1.780	1.780	1.780	1.780	1.780	1.780	2.880	2.880	3.169	3.169	4.178
C	2.638	2.638	2.638	2.980	3.350	3.657	4.126	4.805	6.496	7.402	8.856
D	4.257	4.257	4.257	4.527	4.527	4.527	6.585	6.585	7.717	7.717	9.842

PNEUMATIC SPRING RETURN											
	1/4"	3/8"	1/2"	3/4"	1"	1-1/4"	1-1/2"	2"	2-1/2"	3"	4"
A	5.060	5.060	5.060	5.129	5.504	5.630	6.666	6.998	8.532	8.996	10.315
B	2.880	2.880	2.880	2.880	2.880	2.880	3.175	3.175	4.173	4.173	5.249
C	2.638	2.638	2.638	2.980	3.350	3.657	4.126	4.805	6.496	7.402	8.858
D	6.585	6.585	6.585	6.585	6.585	6.585	7.788	7.788	9.843	9.843	11.693

SPECIFICATIONS

Body: 2 - piece.
Line Size: 1/4" to 4".
End Connections: Female NPT.
Pressure Limit: 600 psi (41 bar) WOG, 100 psi (6.9 bar) SWP.
Wetted Materials: Body, End Cap, Stem: Brass. Ball: Chrome/Nickel plated brass. Seat, Stem Seal: PTFE.
Temperature Limit: 300°F (148°C).
Other Materials: Body Seal, Body O-ring, Stem O-ring: Fluoroelastomer.

Temperature Limit: 0 to 150°F (-17 to 65°C).

Electrical Connection: 1/2" female NPT.

Modulating Input: 4 to 20 mA.

Standard Features: Manual override and position indicator except modulating units.

Pneumatic "DA" and "SR" Series Type: DA Series is double acting and SR Series is spring return (rack and pinion).

Normal Supply Pressure: 80 psi (5.5 bar).

Maximum Supply Pressure: 130 psig (9.0 bar).

Air Connections: 1/4" female NPT.

Air Consumption (per stroke): DA1: 2.32 cu. in.; DA2, SR2: 9.34 cu. in.; DA3, SR3: 17.21 cu. in.; DA5, SR5: 39.54 cu. in.; SR6: 54.37 cu. in.

Cycle Time (per 90°): DA1: .03 sec.; DA2: .05 sec.; DA3: .06 sec.; DA5: .18 sec.; SR2: .09 sec.; SR3: .13 sec.; SR5: .28 sec.; SR6: .39 sec.

Housing Material: Anodized aluminum body and epoxy coated aluminum end caps.

Temperature Limit: -4 to 180°F (-20 to 85°C).

Accessory Mounting: NAMUR standard.

Standard Features: Position indicator.

ACTUATORS

Electric

Power Requirements: 115 VAC, 50/60 HZ, single phase. Optional 220 VAC, 24 VAC, 12 VDC, and 24 VDC.

Power Consumption (Locked Rotor Current): Two position: 1/2" to 1-1/4": 0.55A, 1-1/2" to 2": 0.75A, 2-1/2" to 3": 0.99A. Modulating: 1/2" to 2": 0.75A, 2-1/2" to 3": 0.99A.

Cycle Time (per 90°): Two position: 1/2" to 1-1/4": 2.5 sec., 1-1/2" to 3": 5 sec. Modulating: 10 sec.

Duty Rating: Two position: 1/2" to 1-1/4": 75%, 1-1/2" to 3": 25%. Modulating: 75%.

Enclosure Rating: NEMA 4. Optional NEMA 7.

Housing Material: Aluminum with thermal bonding polyester powder finish.

Size	Cv	Double Acting Pneumatic	Spring Return Pneumatic	Two Position Electric	Modulating Electric	Options: Explosion-proof Electric Actuator -Add suffix "EX" to the model number Optional Electric Actuator Supply Voltages -Contact factory for model number change Solenoid Valve - See Model SV3.
		Model	Model	Model	Model	
1/4"	6.3	ABV1DA100	ABV1SR200			
3/8"	7.0	ABV1DA101	ABV1SR201			
1/2"	19.0	ABV1DA102	ABV1SR202	ABV100	ABV110	
3/4"	19.0	ABV1DA103	ABV1SR203	ABV101	ABV111	
1"	34.5	ABV1DA104	ABV1SR204	ABV102	ABV112	
1-1/4"	50.2	ABV1DA105	ABV1SR205	ABV103	ABV113	
1-1/2"	268.4	ABV1DA206	ABV1SR306	ABV104	ABV114	
2"	309.3	ABV1DA207	ABV1SR307	ABV105	ABV115	
2-1/2"	629.5	ABV1DA308	ABV1SR508	ABV106	ABV116	
3"	944.5	ABV1DA309	ABV1SR509	ABV107	ABV117	
4"	1493.0	ABV1DA510	ABV1SR610			

NOTE: All spring return actuators are factory standard as spring (fail) close.

(B) Items subject to Schedule B discounts.

Compact Valve and Actuator

Pneumatic Actuated, Direct Acting or Spring Return

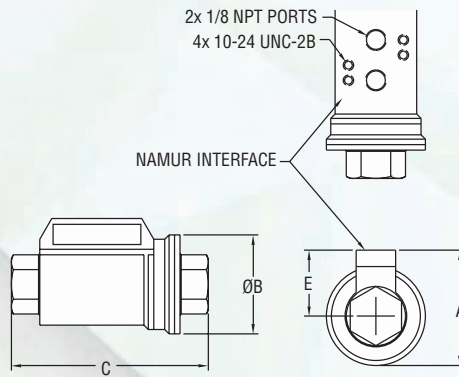

SIZE	A	B	C	D
3/8" (9.53 mm)	2-7/32 [56.36]	1-3/16 [30.16]	3-3/8 [85.73]	1-7/32 [30.96]
1/2" (12.7 mm)	2-15/64 [56.76]	2 [50.8]	4-7/32 [107.16]	1-5/16 [33.34]
3/4" (19.05 mm)	2-9/32 [57.94]	2-7/64 [53.58]	4-59/64 [125.02]	1-33/64 [38.5]
1" (25.4 mm)	3 [76.2]	2-47/64 [69.45]	5-5/16 [134.94]	1-41/64 [41.67]
1-1/4" (31.75 mm)	3-19/32 [91.28]	3-11/32 [84.93]	6-1/32 [153.19]	1-29/32 [48.42]
1-1/2" (38.1 mm)	4 [101.6]	3-25/32 [96.04]	6-47/64 [171.05]	2-1/8 [53.98]
2" (50.8 mm)	4-1/2 [114.3]	4-19/64 [190.14]	7-33/64 [190.9]	2-23/64 [59.93]

CVA Series Actuated Valves

- Integrated pneumatic actuator.
- NAMUR solenoid mounting pad.
- Operating life over 1,000,000 cycles.
- Use in any mounting position.
- Ideal for air drying, laundry, dispensing, and pollution control equipment, process control applications, textile dyeing and drying, and industrial compressors.

Series CVA actuated valves combine a pneumatic actuator and a fast on-off control valve into one body, eliminating packing glands, actuators, and mounting kits. There are no exposed moving parts, eliminating pinch points and increasing operator safety. Because the actuator is part of the valve, costs are greatly reduced when compared to standard actuated valves. Balanced design reduces friction and wear, allowing the operating life to be tested to well over 1,000,000 cycles. The stroke is linear and parallel to the flow, dramatically reducing the required force to close or open the valve. The internal waterway design allows for optimum flow characteristics.

The pneumatic actuated valve can be double acting, spring return normally closed or normally open. The double acting model uses two supply ports (1/8" NPT) with one driving the valve open and the other driving the valve closed. Normally closed spring return pneumatic actuated models use the air supply to open the valve and internally loaded springs return the valve to the closed position. The normally open spring return model uses the air supply to close the valve and internally loaded springs return the valve to the open position.

APPLICATIONS

Ideal to use as an automated on/off valve on the compressed air lines for pneumatic conveying systems or pulse jet dust collectors.

SPECIFICATIONS

Body: 1-piece.

Line Size: 3/8" to 2".

End Connections: NPT female.

Pressure Limit: 225 psig (16 bar).

Wetted Materials: Body: Nickel Plated Brass.

Seals: Buna-N, Fluoroelastomer or EPDM.

Temperature Limit: Buna-N (NBR) seals: -4 to 176°F (-20 to 80°C);
Fluoroelastomer seals: -4 to 302°F (-20 to 150°C);
EPDM seals: -4 to 302°F (-20 to 150°C).

ACTUATORS

Pneumatic

Type: DA is double acting and SR is spring return.

Normal Supply Pressure: 43.5 psig (3 bar) for double acting;
61 psig (4.2 bar) for spring return.

Maximum Supply Pressure: 116 psig (8 bar) for double acting;
116 psig (8 bar) for spring return.

Air Connections: 1/8" NPT.

Air Consumption: 3/8": 0.73 cu. in.; 1/2": 1.05 cu. in.; 3/4": 1.90 cu. in.;
1": 2.45 cu. in.; 1-1/4": 4.58 cu. in.; 1-1/2": 6.70 cu. in.; 2": 12.75 cu. in.

Stroke Time: DA01 & DA02: .01 sec; DA03 & DA04: .02 sec; DA05: .03 sec; DA06: .06 sec; DA07: .07 sec. (spring stroke) NC01 & NC02: .02 sec; NC03: .03 sec; NC04: .04 sec; NC05: .07 sec; NC06: .11 sec; NC07: .13 sec. (air stroke) NC01 & NC02: .01 sec; NC03 & NC04: .02 sec; NC05: .04 sec; NC06: .06 sec; NC07: .07 sec. NO same as NC.

Accessory Mounting: NAMUR.

Sizes	Seat & Seal Material	Cv	Double Acting	Spring Return: Normally Closed	Spring Return: Normally Open
			Model	Model	Model
3/8"	Fluoroelastomer	8	CVAA-DA01	CVAA-NC01	CVAA-NO01
1/2"	Fluoroelastomer	10	CVAA-DA02	CVAA-NC02	CVAA-NO02
3/4"	Fluoroelastomer	13	CVAA-DA03	CVAA-NC03	CVAA-NO03
1"	Fluoroelastomer	17	CVAA-DA04	CVAA-NC04	CVAA-NO04
1-1/4"	Fluoroelastomer	28	CVAA-DA05	CVAA-NC05	CVAA-NO05
1-1/2"	Fluoroelastomer	57	CVAA-DA06	CVAA-NC06	CVAA-NO06
2"	Fluoroelastomer	81	CVAA-DA07	CVAA-NC07	CVAA-NO07
3/8"	EPDM	8	CVAB-DA01	CVAB-NC01	CVAB-NO01
1/2"	EPDM	10	CVAB-DA02	CVAB-NC02	CVAB-NO02
3/4"	EPDM	13	CVAB-DA03	CVAB-NC03	CVAB-NO03
1"	EPDM	17	CVAB-DA04	CVAB-NC04	CVAB-NO04
1-1/4"	EPDM	28	CVAB-DA05	CVAB-NC05	CVAB-NO05
1-1/2"	EPDM	57	CVAB-DA06	CVAB-NC06	CVAB-NO06
2"	EPDM	81	CVAB-DA07	CVAB-NC07	CVAB-NO07
3/8"	BUNA-N	8	CVAC-DA01	CVAC-NC01	CVAC-NO01
1/2"	BUNA-N	10	CVAC-DA02	CVAC-NC02	CVAC-NO02
3/4"	BUNA-N	13	CVAC-DA03	CVAC-NC03	CVAC-NO03
1"	BUNA-N	17	CVAC-DA04	CVAC-NC04	CVAC-NO04
1-1/4"	BUNA-N	28	CVAC-DA05	CVAC-NC05	CVAC-NO05
1-1/2"	BUNA-N	57	CVAC-DA06	CVAC-NC06	CVAC-NO06
2"	BUNA-N	81	CVAC-DA07	CVAC-NC07	CVAC-NO07

*Solenoid Valve – See Model SV3

Series
BFV

Butterfly Valves

Low Cost, Lever Operated, Lug or Wafer Pattern, 225 psig

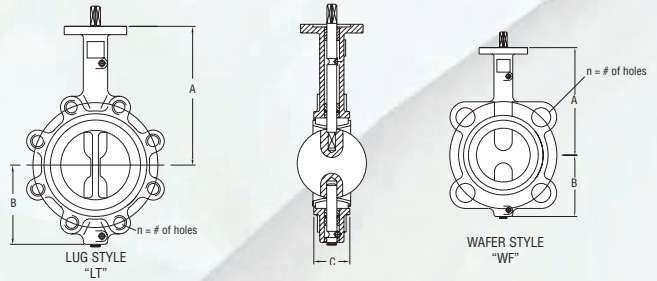

DIMENSIONS (in)

Size	A	B	C	n, WF	n, LT	Cv	Weight	Size	A	B	C	n, WF	n, LT	Cv	Weight
2"	6.34	3.15	1-3/4	4	4	135	5.5	6"	8.9	5.47	2-1/4	8	8	1579	17.2
2-1/2"	6.89	3.5	1-7/8	4	4	220	7.05	8"	10.24	6.89	2-1/2	8	8	3136	29.1
3"	7.13	3.74	1-7/8	4	4	302	7.93	10"	11.5	7.99	2-3/4	12	12	5340	42.33
4"	7.87	4.49	2-1/8	4	8	600	10.8	12"	13.27	9.53	3-1/8	12	12	8250	71.65
5"	8.39	5	2-1/4	8	8	1022	15.43								

Series BFV Butterfly Valves

- Phenolic backed cartridge seat design for extended service and ease of replacement. Can be used for vacuum service.
- Extended neck for insulation - no fabricated extensions required.
- Machined flats attach disc/stem - no pins.
- Valve features a retainer lip for dead end service.
- Triple seal reduces possibility of external leakage.
- Silicone free from the factory - no aftermarket cleaning required.

The most critical aspect of the Series BFV Butterfly Valves is the cartridge seat design, which alleviates installation problems associated with common "dove tail design" seats. Valve torque is lower and more consistent because the seat dynamics do not rely on being mated between two flanges. Precision machining of the disc and body allow the cartridge design to maintain a tighter disc to seat tolerance, providing a perfect low torque seal each and every time the valve is cycled. Seat to disc seal is independent of flange support and capable of full rated dead end service. Select from wafer or lug patterns with either a 10-position locking handle lever or manual gear operator. Standard valves provide bubble tight sealing to 225 psi (15.5 bar) and are designed to comply with MSS-SP-67 and API-609. Series BFV is perfect for use in pneumatic conveying systems for controlling flow of product out of silos or bins.

SPECIFICATIONS

VALVE BODY
Service: Compatible liquids, gases, and steam.
Line Size: 2" to 12".
Body Style: 2-way, wafer or lug butterfly.
End Connections: Flange, to be used with flanges that are ANSI Class 125 (B16.1) and ANSI Class 150 (B16.5) dimensions.
Pressure Limit: 225 psi (15.5 bar) WOG.

Wetted Materials:

Body Material: Ductile iron.
Seat: 316 SS.
Stem and O-ring: EPDM or PTFE.
Stem: 410 SS.
Temperature Limits: Disc: EPDM: -50 to 250°F (-46 to 121°C). PTFE: 0 to 300°F (-18 to 149°C).
Bearings: Nylontron.
Flow Rate: See Cv chart.
Operator: 2 to 6": 10-position locking hand lever. 8 to 12": manual gear.

APPLICATIONS

- Perfect for on-off or throttling service
- Material control in pneumatic conveying systems

Cv VALUES

Size	DEGREE OPENING									FULL OPEN
	10°	20°	30°	40°	50°	60°	70°	80°	90°	
2"	0.1	5	12	24	45	64	90	125	135	
2-1/2"	0.2	8	20	37	65	98	144	204	220	
3"	0.3	12	22	39	70	116	183	275	302	
4"	0.5	17	36	78	139	230	364	546	600	
5"	0.8	29	61	133	237	392	620	930	1022	
6"	2	45	95	205	366	605	958	1437	1579	
8"	3	89	188	408	727	1202	1903	2854	3136	
10"	4	151	320	694	1237	2047	3240	4859	5340	
12"	5	234	495	1072	1911	3162	5005	7505	8250	

Cv is the number of U.S. GPM of 60°F water that will pass through the valve with a 1 PSI pressure drop.

OPERATING TORQUE VALUES (INCH LB)

EPDM Seats	Size (inches)								
	2	2-1/2	3	4	5	6	8	10	12
Service Pressure									
50 psi	86	126	179	295	540	750	1440	2466	3510
100 psi	108	144	195	310	610	780	1490	2910	4100
150 psi	126	150	210	335	699	847	1549	3360	5560
200 psi	150	198	297	400	725	940	1800	3890	7558

PTFE Seats	Size (inches)								
	2	2-1/2	3	4	5	6	8	10	12
Service Pressure									
50 psi	125	130	195	390	650	890	1690	3699	5265
100 psi	130	145	210	430	690	940	1710	4365	6150
150 psi	142	160	248	443	720	974	1770	5040	8340
200 psi	180	220	340	490	795	1020	1890	5835	11367

Size	Liner	Model	Size	Liner	Model
2"	EPDM	BFV202WFB311HLO	5"	EPDM	BFV205LTB311HLO
	PTFE	BFV202WFB341HLO		PTFE	BFV205LTB341HLO
	EPDM	BFV202LTB311HLO	6"	EPDM	BFV206WFB311HLO
	PTFE	BFV202LTB341HLO		PTFE	BFV206WFB341HLO
2-1/2"	EPDM	BFV225WFB311HLO	8"	EPDM	BFV208WFB312MG0
	PTFE	BFV225WFB341HLO		PTFE	BFV208WFB342MG0
	EPDM	BFV225LTB311HLO	10"	EPDM	BFV210WFB312MG0
	PTFE	BFV225LTB341HLO		PTFE	BFV210WFB342MG0
3"	EPDM	BFV203WFB311HLO	12"	EPDM	BFV212WFB312MG0
	PTFE	BFV203WFB341HLO		PTFE	BFV212WFB342MG0
	EPDM	BFV203LTB311HLO			
	PTFE	BFV203LTB341HLO			
4"	EPDM	BFV204WFB311HLO			
	PTFE	BFV204WFB341HLO			
	EPDM	BFV204LTB311HLO			
	PTFE	BFV204LTB341HLO			
5"	EPDM	BFV205WFB311HLO			
	PTFE	BFV205WFB341HLO			

BFV202WFB311HLO WF=Wafer Pattern LT=Lug Pattern

Series ABFV Automated Butterfly Valve

Resilient Seated, Direct Mount Actuators



Pneumatic



Electric

*Please see website for dimensional drawings

The ABFV Series is offered with standard 316 SS disc, a through shaft that does not come in contact with the media, and choices of EPDM, BUNA-N, or fluoroelastomer liners for great chemical compatibility. Valve design has integral ISO mounting for direct mount actuators creating a more compact automated package. Body is epoxy coated for durable and attractive finish. Liner fully covers the body and assures tight seal with mating flanges without additional gaskets. One-piece shaft ensures positive valve positioning and is an anti-blowout design. Series ABFV is perfect for use in pneumatic conveying systems for controlling flow of product out of silos or bins.

ABFV valves come in two-way and three-way packages. Three-way assemblies include valves and actuators mounted onto a 125# cast iron tee. When ordering you have the choice of valve arrangement for mixing or diverting applications. Valves come in lug or wafer style and wafer models have guide holes for bolts.

ABFV is an economical automated valve package with either an electric or pneumatic actuator. Electrically actuated models are weatherproof, NEMA 4, powered by standard 115 VAC supply, and are available in either two-position or proportional control. Two-position actuators use the 115 VAC input to drive each of the valve ports open or closed, while the modulating actuator accepts a 4 to 20 mA input for infinite valve positioning. Actuator features include thermal overload protection to withstand stall conditions, visual position indication and a permanently lubricated gear train.

The pneumatic double acting actuator uses an air supply to drive each of the actuator ports. Spring return pneumatic actuators use the air supply to drive the valve stem one direction, and internally loaded springs return the valve to its original position. Also available is the SV3 solenoid valve to electrically switch the supply pressure between the air supply ports. Actuators are constructed of anodized aluminum and are epoxy coated for years of corrosion free service.

Cv Values

Valve Size	10°	20°	30°	40°	50°	60°	70°	80°	90°
2"	0.1	5	12	24	45	64	90	125	135
2-1/2"	0.7	8	20	37	65	98	144	204	220
3"	0.3	12	22	39	70	116	183	275	302
4"	0.5	17	36	78	139	230	364	546	600
5"	0.8	29	61	133	237	392	620	930	1022
6"	2	45	95	205	366	605	958	1437	1539
8"	3	89	188	408	727	1202	1903	2854	3136
10"	4	151	320	694	1237	2034	3240	4859	5340
12"	5	234	495	1072	1911	3162	5005	7507	8250

SPECIFICATIONS

Valve Body

Service: Compatible liquids and gases.

Body: 2-way or 3-way.

Line Size: 2" to 12".

End Connections: Wafer or lug pattern designed for flanges to ANSI B16.1, BS4504, DIN 2501.

Pressure Limits: Up to 8": 225 psi (15.5 bar); 10" – 12": 150 psi (10.3 bar).

Wetted Materials: Disc: 316 SS; Liner: EPDM BUNA-N, or Fluoroelastomer.

Temperature Limits: EPDM: -30 to 275°F (-34 to 135°C); BUNA-N: 10 to 180°F (-12.2 to 82.2°C); Fluoroelastomer: 400°F (204°C).

Other Materials: Shaft: 316SS; Bottom/Top Bushing: bronze; Body: cast iron; Shaft Seal: EPDM.

ACTUATORS

Electric "U" and "V" Series

Power Requirements: 115 VAC, 50/60 Hz, single phase. Optional 220 VAC, 24 VAC, 12 VDC, and 24 VDC.

Power Consumption: (Locked Rotor Current): U_1, V_1: .55A; U_2, 3, 4, V_2, 3, 4: 0.75A; U_5, 6, 7, V_5, 6, 7: 1.1A; U_8, V_8: 2.6A; U_9, V_9: 2.9A. (Only for 115 VAC, for other voltages contact the factory).

Cycle Time: (sec. per 90°): U_1, V_1: 2.5; U_2, 3, V_2, 3: 5; U_4, V_4: 10; U_5, 6, V_5, 6: 15; U_7, V_7: 30; U_8, V_8: 12; U_9, V_9: 14. (Only for 115 VAC, for other voltages contact the factory).

Duty Cycle: U_1: 75%; U_2 to 7: 25%; U_8, 9: 100%; V_1 to 7: 75%; V_8, 9: 100%.

Enclosure Rating: NEMA 4. Optional NEMA 7 (Class 1, Div. II Groups A, B, C, D).

Housing Material: Aluminum with thermal bonding polyester powder finish.

Temperature Limit: 0 to 150°F (-18 to 65°C).

Conduit Connection: 1/2" female NPT.

Modulating Input (V Series): 4 to 20 mA.

Standard Features: Manual override and visual position indicator except modulating units.

Pneumatic "DA" and "SR" Series

Type: DA series is double acting and SR series is spring return (rack and pinion).

Normal Supply Pressure: 80 psi (5.5 bar).

Maximum Supply Pressure: 120 psig (8 bar).

Air Connections: DA1 to 5 and SR2 to 5: 1/8" female NPT, all others: 1/4" female NPT.

Air Consumption: (cu. in. per stroke) DA1: 2.32, DA2: 6.59, DA3: 12.14, DA4: 16.32, DA5: 30.2, DA6: 45.3, DA7: 61.0, DA8: 106.9, DA9: 137.9, DAA: 220.1, DAB: 348.1, DAC: 915.4, SR2: 7.7, SR3: 14.2, SR4: 17.2, SR5: 32.4, SR6: 54.4, SR7: 85.4, SR8: 122.1, SR9: 146.5, SRA: 215.1, SRB: 462.6, SRC: 945.9.

Cycle Time: (sec. per 90°): DA1: .03, DA2: .04, DA3: .08, DA4: .12, DA5: .19, DA6: 0.27, DA7: .47, DA8: .66, DA9: .93, DAA: 1.1, DAB: 1.7, DAC: 4.5, SR2: .09, SR3: .14, SR4: .22, SR5: .33, SR6: .46, SR7: .78, SR8: .90, SR9: .97, SRA: 1.34, SRB: 2.19, SRC: 6.20.

Housing Material: Anodized aluminum body and epoxy coated aluminum end caps.

Temperature Limit: -4 to 180°F (-20 to 82°C).

Accessory Mounting: NAMUR standard.

Standard Features: Visual position indicator.

Complete Model Chart - See next page for built model numbers.

Example	ABFV	3	03	WFB	3	3	1	DA3	E	SV	ABFV303WFB331DA3E-SV
Construction	ABFV										Automated Butterfly Valve
Configuration		2 3									Two-Way Three-Way
Size			02 25 03 04 05 06 08 10 12								2" 2-1/2" 3" 4" 5" 6" 8" 10" 12"
Body				WFB LTB							Wafer Lug
Stem					3						316 SS
Disc						3					316 SS
Liner							1 2 3				EPDM Buna-N Fluoroelastomer
Actuator Type								DA1 DA2 DA3 DA4 DA5 DA6 DA7 DA8 DA9 DAA DAB DAC SR2 SR3 SR4 SR5 SR6 SR7 SR8 SR9 SRA SRB SRC U_1 U_2 U_3 U_4 U_5 U_6 U_7 U_8 U_9 U_A V_1 V_2 V_3 V_4 V_5 V_6 V_7 V_8 V_9 V_A			Direct Acting Rack and Pinion Actuator, Size 32 Direct Acting Rack and Pinion Actuator, Size 52 Direct Acting Rack and Pinion Actuator, Size 63 Direct Acting Rack and Pinion Actuator, Size 75 Direct Acting Rack and Pinion Actuator, Size 85 Direct Acting Rack and Pinion Actuator, Size 100 Direct Acting Rack and Pinion Actuator, Size 115 Direct Acting Rack and Pinion Actuator, Size 125 Direct Acting Rack and Pinion Actuator, Size 140 Direct Acting Rack and Pinion Actuator, Size 160 Direct Acting Rack and Pinion Actuator, Size 200 Direct Acting Rack and Pinion Actuator, Size 270 Spring Return Rack and Pinion Actuator, Size 52 Spring Return Rack and Pinion Actuator, Size 63 Spring Return Rack and Pinion Actuator, Size 75 Spring Return Rack and Pinion Actuator, Size 85 Spring Return Rack and Pinion Actuator, Size 100 Spring Return Rack and Pinion Actuator, Size 115 Spring Return Rack and Pinion Actuator, Size 125 Spring Return Rack and Pinion Actuator, Size 140 Spring Return Rack and Pinion Actuator, Size 160 Spring Return Rack and Pinion Actuator, Size 200 Spring Return Rack and Pinion Actuator, Size 270 Electric Two Position, Size 100 Electric Two Position, Size 200 Electric Two Position, Size 300 Electric Two Position, Size 400 Electric Two Position, Size 675 Electric Two Position, Size 1000 Electric Two Position, Size 1500 Electric Two Position, Size 2000 Electric Two Position, Size 3800 Electric Two Position, Size 5000 Electric Modulating, Size 100 Electric Modulating, Size 200 Electric Modulating, Size 300 Electric Modulating, Size 400 Electric Modulating, Size 675 Electric Modulating, Size 1000 Electric Modulating, Size 1500 Electric Modulating, Size 2000 Electric Modulating, Size 3800 Electric Modulating, Size 5000
Arrangement									A C E G I K L M		2-Way, Normally Open 2-Way, Normally Closed 3-Way, Common/NO/NC 3-Way, Common/NC/NO 3-Way, NO/Common/NC 3-Way, NC/Common/NO 3-Way, NO/NC/Common 3-Way, NC/NO/Common
Options										SV EX	Factory Mounted Solenoid Valve (Pneumatic Only) Explosion-Proof Electric Actuator (Electric Only)

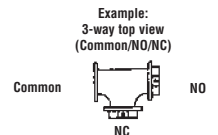

For Electric U and V actuators middle term, V_1, is the power supply required. Model Code 1 is for 120 VAC, 2 is for 220 VAC, 3 is for 24 VAC and 4 is for 24 VDC. Example, U11, is 120 VAC two position. Consult factory for pricing.

For your convenience, sample model configurations are listed with the proper sized actuators. Models listed have cast iron body, 316 SS disc, and EPDM liner and o-rings. The 2-way models have a valve arrangement shown of normally closed, while the 3-way models have no valve arrangement code shown, please specify when ordering. All electric actuators shown are 115 VAC and NEMA 4. All pneumatic actuators are sized with an air supply pressure of 80 psi. Consult the factory for model number changes for electric actuator options of explosion-proof and other supply voltages.

2-Way, Lug Style, EPDM Liner

Size	Double Acting Pneumatic	Spring Return Pneumatic	Two Position Electric	Modulating Electric
	Model	Model	Model	Model
2"	ABFV202LTB331DA2C	ABFV202LTB331SR4C	ABFV202LTB331U12C	ABFV202LTB331V12C
2-1/2"	ABFV225LTB331DA2C	ABFV225LTB331SR4C	ABFV225LTB331U12C	ABFV225LTB331V12C
3"	ABFV203LTB331DA3C	ABFV203LTB331SR5C	ABFV203LTB331U13C	ABFV203LTB331V13C
4"	ABFV204LTB331DA3C	ABFV204LTB331SR6C	ABFV204LTB331U14C	ABFV204LTB331V14C
5"	ABFV205LTB331DA5C	ABFV205LTB331SR6C	ABFV205LTB331U16C	ABFV205LTB331V16C
6"	ABFV206LTB331DA5C	ABFV206LTB331SR8C	ABFV206LTB331U16C	ABFV206LTB331V16C
8"	ABFV208LTB331DA6C	ABFV208LTB331SR8C	ABFV208LTB331U17C	ABFV208LTB331V17C
10"	ABFV210LTB331DA8C	ABFV210LTB331SR9C	ABFV210LTB331U19C	ABFV210LTB331V19C
12"	ABFV212LTB331DAAC	ABFV212LTB331SRBC	ABFV212LTB331U19C	ABFV212LTB331V19C

Model Numbers shown are normally closed, change the model code at the end from "C" to "A" for normally open.

2-Way, Wafer Style, EPDM Liner

Size	Double Acting Pneumatic	Spring Return Pneumatic	Two Position Electric	Modulating Electric
	Model	Model	Model	Model
2"	ABFV202WFB331DA2C	ABFV202WFB331SR4C	ABFV202WFB331U12C	ABFV202WFB331V12C
2-1/2"	ABFV225WFB331DA2C	ABFV225WFB331SR4C	ABFV225WFB331U12C	ABFV225WFB331V12C
3"	ABFV203WFB331DA3C	ABFV203WFB331SR5C	ABFV203WFB331U13C	ABFV203WFB331V13C
4"	ABFV204WFB331DA3C	ABFV204WFB331SR6C	ABFV204WFB331U14C	ABFV204WFB331V14C
5"	ABFV205WFB331DA5C	ABFV205WFB331SR6C	ABFV205WFB331U16C	ABFV205WFB331V16C
6"	ABFV206WFB331DA5C	ABFV206WFB331SR8C	ABFV206WFB331U16C	ABFV206WFB331V16C
8"	ABFV208WFB331DA6C	ABFV208WFB331SR8C	ABFV208WFB331U17C	ABFV208WFB331V17C
10"	ABFV210WFB331DA8C	ABFV210WFB331SR9C	ABFV210WFB331U19C	ABFV210WFB331V19C
12"	ABFV212WFB331DAAC	ABFV212WFB331SRBC	ABFV212WFB331U19C	ABFV212WFB331V19C

Model Numbers shown are normally closed, change the model code at the end from "C" to "A" for normally open.

3-Way, Lug Style, EPDM Liner

Size	Double Acting Pneumatic	Spring Return Pneumatic	Two Position Electric	Modulating Electric
	Model*	Model*	Model*	Model*
2"	ABFV302LTB331DA3_	ABFV302LTB331SR5_	ABFV302LTB331U13_	ABFV302LTB331V13_
2-1/2"	ABFV325LTB331DA3_	ABFV325LTB331SR6_	ABFV325LTB331U14_	ABFV325LTB331V14_
3"	ABFV303LTB331DA4_	ABFV303LTB331SR6_	ABFV303LTB331U15_	ABFV303LTB331V15_
4"	ABFV304LTB331DA5_	ABFV304LTB331SR7_	ABFV304LTB331U16_	ABFV304LTB331V16_
5"	ABFV305LTB331DA6_	ABFV305LTB331SR9_	ABFV305LTB331U16_	ABFV305LTB331V16_
6"	ABFV306LTB331DA7_	ABFV306LTB331SR9_	ABFV306LTB331U17_	ABFV306LTB331V17_
8"	ABFV308LTB331DA9_	ABFV308LTB331SR9_	ABFV308LTB331U19_	ABFV308LTB331V19_
10"	ABFV310LTB331DAA_	ABFV310LTB331SRB_	ABFV310LTB331U19_	ABFV310LTB331V19_
12"	ABFV312LTB331DAB_	ABFV312LTB331SRC_	ABFV312LTB331U1A_	ABFV312LTB331V1A_

*Complete model includes Valve Arrangement - see Model Chart on previous page.

Options:

Explosion-proof Electric Actuator
-Add suffix "EX" to the model number

Optional Electric Actuator Supply Voltages
-Contact factory for model number change

Sizes up to U_6, V_6
Sizes U_7, V_7 and up

Solenoid Valve - Add suffix -SV

Series
QV

QUICK-VIEW[®] Valve Position Indicator/Switch

Ultra-Low Cost, Compact, Backlit, Corrosion Resistant

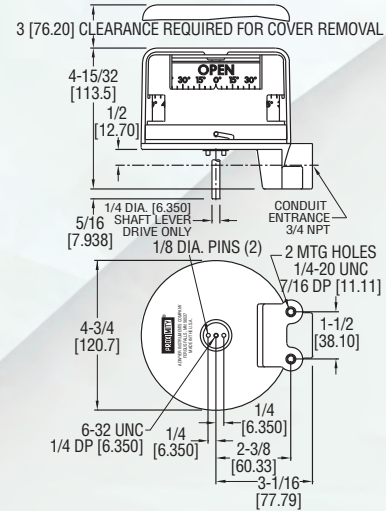

FEATURES AND BENEFITS

The QUICK-VIEW[®] Rotary Valve Position Indicators, now UL and CSA rated, are produced by Proximity with up to four individual mechanical or proximity switches. The QUICK-VIEW[®] indicator is also available with optional backlighting. Benefits include:

- The lowest cost position indication.
- Extremely compact design.
- Easily interchangeable with key competition.
- Backlighting option available for maximum visibility.
- QUICK-VIEW[®] Indicator and mounting kits, including NAMUR kits, are stocked for fast delivery.
- Flame retardant.
- UV protection.
- Hazardous location option.

APPLICATIONS

The QV Series Proximity Position Indicators are designed for maximum reliability in general purpose and corrosive environments. Applications include: rotary and linear valves, actuators, manual valves, gear operators and positioners.

Consult factory for optional VI colors.

Model Number	Backlighting
QV-210101	No
QV-210111	Yes

Note: Stocked position indicators include two 10 amp SPDT mechanical snap switches, are direct drive type and include the standard quarter-turn OPEN/CLOSED visual indicator. Standard units are CSA & UL approved but not for hazardous locations. Specify "EX" for hazardous location option.

SPECIFICATIONS

Minimum Rotation Travel – Switches only: 5°.
Maximum Rotation Travel – Switches only: 360°.
Temperature Limits: -40 to 180°F (-40 to 82°C).
Switch Type: SPDT.

Electrical SPDT Switch Ratings:

- QV-X1XXXX:** 10A @ 125/250 VAC; 0.5A 125 VDC; 10A @ 24 VDC mech. switch.
- QV-X2XXXX:** 1A @ 125 VAC; 1A @ 24 VDC mech. switch.
- QV-X3XXXX:** 2A @ 125 VAC; 2A @ 30 VDC prox. switch.
- QV-X4XXXX:** 5-25 VDC NAMUR sensor.
- QV-X5XXXX:** 10-30 VDC INDUCTIVE sensor.
- QV-X6XXXX:** 10A @ 125/250 VAC mech. switch.

Lighting Supply Voltage: 24-28 VDC.

Enclosure Material: Polycarbonate housing and conduit.

Conduit Entrance: One 3/4" NPT.

Enclosure Rating: NEMA 4, 4X. Optional explosion-proof, rated: Class I, Groups A, B, C, D; Class II, Groups F & G; Div. 2.

Maximum Altitude: 2000 m (6560 ft).

QUICK-VIEW[®] COMPLETE MODEL CHART

QV	Model Number Prefix						
	1st Code (1st X) Number of Switches						
0	None+						
1	One Switch+						
2	Two Switches+						
3	Three Switches+						
4	Four Switches+						
	2nd Code (2nd X) Switch Type						
0	No Switches+						
1	10A Mechanical Snap Switch						
2	0.1A Mechanical Gold Contacts						
3	2A Proximity Reed Switch+						
4	5-25 VDC Namur Sensor						
5	10-30 VDC Inductive Sensor						
6	10A Mechanical Snap Switch						
	3rd Code (3rd X)						
0							
	4th Code (4th X) Driving Style						
1	Direct Drive+						
2	Lever Drive+						
3	Namur Drive+						
	5th Code (5th X) Lighting Option						
0	None+						
1	28 VDC Lights						
	6th Code (6th X) Visual Indication						
0	None						
1	Standard (Open Closed)+						
2	Upside Down (Open Closed)+						
	7th Code (7th X) Additional Options						
EX	Class I, Div. II, Groups A, B, C & D. Class II, Div. II Groups F & G.						
QV	2	1	0	1	0	1	- Example Popular Model Number

+ EX, Explosion-proof option available.

Note: The 1st, 2nd, 3rd and 6th codes can not all be zero.

Filters, Regulators and Lubricators

For Pneumatic Air Applications, Keep Plant Instrumentation & Valves Operating Properly

Series F Filters



F1

F2

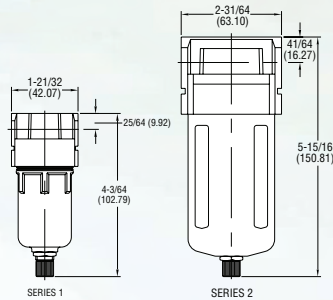

Series R Regulators



R1

R2

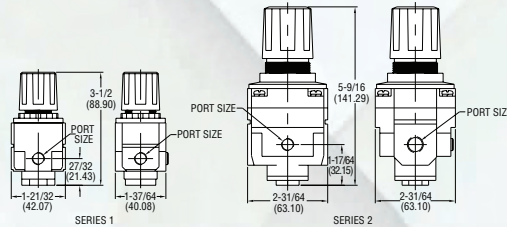

Series L Lubricators



L1

L2

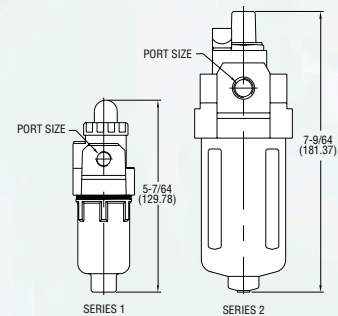

F Series Filters keep air and pneumatic systems operating cleanly and efficiently. Port sizes, filter elements, and drain options available to service broad application requirements.

R Series Pressure Regulators offer economic prices and high performance pressure regulation. Configurable units offer a variety of fitting and port sizes, and supply pressures ranging from 10 to 120 psig. The non-rising adjustment knob allows for simple and precise monitoring of pressure and features push-pull lock ring.

L Series Lubricators maintain safe operation and longevity of pneumatic systems. Top plug permits filling without removing bowl or disconnecting air-lines. Adjustable drop rate fits any application.

These products are well suited for compressed air lines. Using them will ensure proper instrument & valve performance.

Model Number	Process Connection	Filtration	Drain
F1-150M	1/8" NPT	50 microns	Manual
F2-250M	1/4" NPT	50 microns	Manual

Model Number	Process Connection	Pressure Range
R1-1120	1/8" NPT	120 psi
R2-2120	1/4" NPT	120 psi

Model Number	Process Connection
L1-1	1/8" NPT
L2-2	1/4" NPT

SPECIFICATIONS

	Size 1	Size 2
GENERAL		
Service	Air	Air
Temperature Limits	41 to 140°F (5 to 60°C)	41 to 140°F (5 to 60°C)
Maximum Supply Pressure	165 psig	165 psig
FILTERS		
Process Connection	1/8", 1/4" NPT	1/4", 3/8", 1/2" NPT
Filtration (micron)	5μ, 25μ, 50μ	5μ, 25μ, 50μ
Maximum Supply Pressure	165 psi	165 psi
Drain	Manual/Semi-Auto	Manual/Semi-Auto
Bowl Capacity	0.75 inch ³	2.75 inch ³
Flow (based on 100 psi inlet pressure w/ 50 micron filter)	55, 85 SCFM	120, 120, 120 SCFM
Construction	Body: Aluminum; Filter: Sintered Bronze	
REGULATORS		
Process Connection	1/8", 1/4" NPT	1/4", 3/8", 1/2" NPT
Effect of Supply Pressure Variation (25 psig) on Outlet Pressure	<0.2 psig	<0.2 psig
Exhaust Capacity (5 psig above 20 psig set point)	<0.25 SCFM	<0.25 SCFM
Flow Capacity at 100 psig Supply and 70 psig Outlet	40, 60 SCFM	90, 120, 120 SCFM
Output Pressure Ranges	0-10 psig 0-30 psig 0-60 psig 0-120 psig	0-10 psig 0-30 psig 0-60 psig 0-120 psig
Total Air Consumption @ Maximum Output	0.3 SCFH	0.3 SCFH
Construction	Body: Aluminum; Bowl: Polycarbonate	
LUBRICATORS		
Process Connection	1/8", 1/4" NPT	1/4", 3/8", 1/2" NPT
Lubrication	Mist	Mist
Bowl Capacity	1.22 inch ³	5 inch ³
Flow (based on 100 psi inlet pressure)	55, 115 SCFM	125, 125, 125 SCFM
Construction	Body: Aluminum	

FEATURES

Filter

- Polycarbonate bowl with metal guard
- Filter options 5 μ , 25 μ , 50 μ
- Manual, semi-automatic or automatic drain options

Regulator

- Rolling diaphragm
- Panel/pipe/bracket mountable
- Aluminum body, polycarbonate bonnet and knob
- Non-rising adjustment knob with push-pull lock ring

Lubricator

- Field serviceable polycarbonate bowl
- Polycarbonate bowl includes metal guard and top plug
- Adjustable drip rate

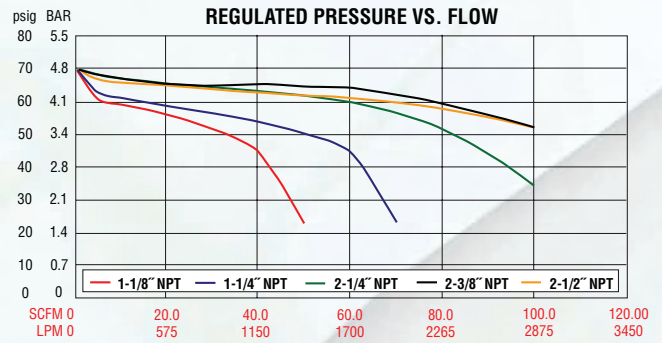

F Series Filters

Function	F					Filter
Body Style	1					1 Size
	2		-			2 Size
Process Connection				1		1/8" NPT (1 Size only)
				2		1/4" NPT
				3		3/8" NPT (2 Size only)
				4		1/2" NPT (2 Size only)
Filtration					50	50 micron filter
					25	25 micron filter
					05	5 micron filter
Drain						M Manual drain
						S Semi-Automatic drain
						A Automatic drain (2 Size only)

R Series Pressure Regulators

Function	R					Regulator
Body Style	1					1 Size
	2		-			2 Size
Process Connection				1		1/8" NPT (1 Size only)
				2		1/4" NPT
				3		3/8" NPT (2 Size only)
				4		1/2" NPT (2 Size only)
Pressure Range					010	0-10 psi outlet pressure
					030	0-30 psi outlet pressure
					060	0-60 psi outlet pressure
					120	0-120 psi outlet pressure

L Series Lubricators

Function	L					Lubricator
Body Style	1					1 Size
	2		-			2 Size
Process Connection				1		1/8" NPT (1 Size only)
				2		1/4" NPT
				3		3/8" NPT (2 Size only)
				4		1/2" NPT (2 Size only)

Series FR Filter-Regulator

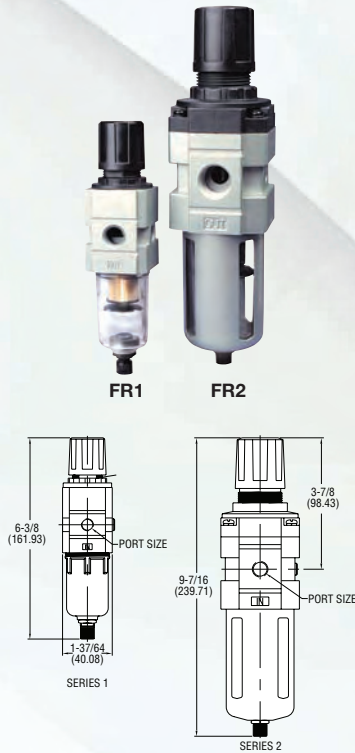

Series FRL Filter-Regulator-Lubricator

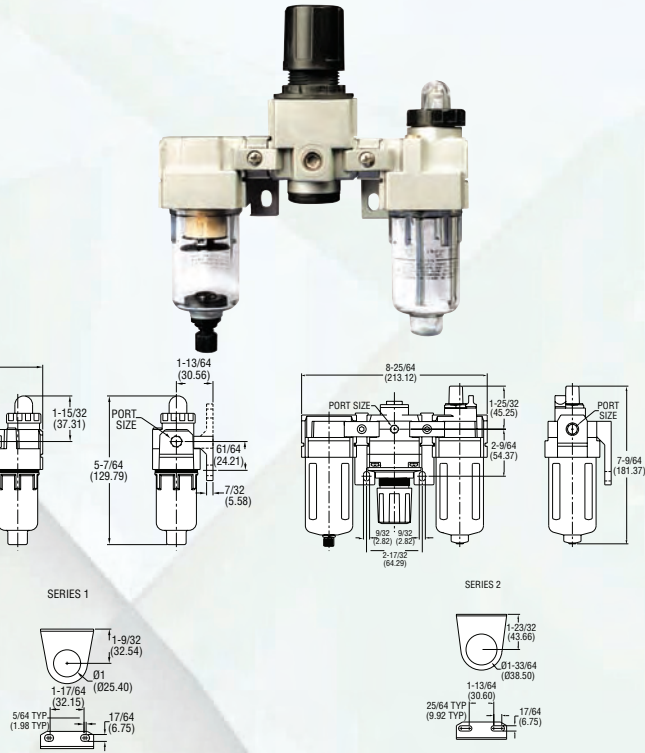

The Series FR Filter-Regulators are combination units that provide maximum options in minimal space. Constructed of aluminum and polycarbonate, these rugged units offer the same air pressure regulation features as our standard R Series units side-by-side with the convenience of an F Series filter. Unscrewing the adjustment knob and retaining flange easily adapts panel or bracket mounting.

The Series FRL takes the FR Series to the next level by including an L Series lubricator. The package is completely installed and ready to go right out of the box.

These products are well suited for compressed air lines. Using them will ensure proper instrument & valve performance.

Model Number	Process Connection	Pressure Range	Filtration
FR1-112050M	1/8" NPT	120 psi	50 microns
FR2-212050M	1/4" NPT	120 psi	50 microns
FRL1-112050M	1/8" NPT	120 psi	50 microns
FRL2-212050M	1/4" NPT	120 psi	50 microns

SPECIFICATIONS

	Size 1	Size 2
GENERAL		
Service	Air	Air
Temperature Limits	41 to 140°F (5 to 60°C)	41 to 140°F (5 to 60°C)
Maximum Supply Pressure	165 psig	165 psig
FILTERS		
Process Connection	1/8", 1/4" NPT	1/4", 3/8", 1/2" NPT
Filtration (micron)	5μ, 25μ, 50μ	5μ, 25μ, 50μ
Maximum Supply Pressure	165 psi	165 psi
Drain	Manual/Semi-Auto	Manual/Semi-Auto
Bowl Capacity	0.75 inch ³	2.75 inch ³
Flow (based on 100 psi inlet pressure w/ 50 micron filter)	55, 85 SCFM	120, 120, 120 SCFM
Construction	Body: Aluminum; Filter: Sintered Bronze	
REGULATORS		
Process Connection	1/8", 1/4" NPT	1/4", 3/8", 1/2" NPT
Effect of Supply Pressure Variation (25 psig) on Outlet Pressure	<0.2 psig	<0.2 psig
Exhaust Capacity (5 psig above 20 psig set point)	<0.25 SCFM	<0.25 SCFM
Flow Capacity at 100 psig Supply and 70 psig Outlet	40, 60 SCFM	90, 120, 120 SCFM
Output Pressure Ranges	0-10 psig 0-30 psig 0-60 psig 0-120 psig	0-10 psig 0-30 psig 0-60 psig 0-120 psig
Total Air Consumption @ Maximum Output	0.3 SCFH	0.3 SCFH
Construction	Body: Aluminum; Bowl: Polycarbonate	
LUBRICATORS		
Process Connection	1/8", 1/4" NPT	1/4", 3/8", 1/2" NPT
Lubrication	Mist	Mist
Bowl Capacity	1.22 inch ³	5.18 inch ³
Flow (based on 100 psi inlet pressure)	55, 115 SCFM	125, 125, 125 SCFM
Construction	Body: Aluminum	

FEATURES

FR Filter Regulator Combo

- Aluminum and polycarbonate construction
- Manual, semi-auto or autodrain available
- 1 Size has polycarbonate bowl, 2 Size has polycarbonate bowl with metal guard
- Non-rising adjustment knob with push-pull lock ring feature
- Panel or bracket mounting

FRL Package

- All-in-one package ready for installation
- Automatic drain
- 50µ filter standard (others available)
- 120 psi regulator & 1/8" NPT on 1 Size
120 psi regulator & 1/4" NPT on 2 Size

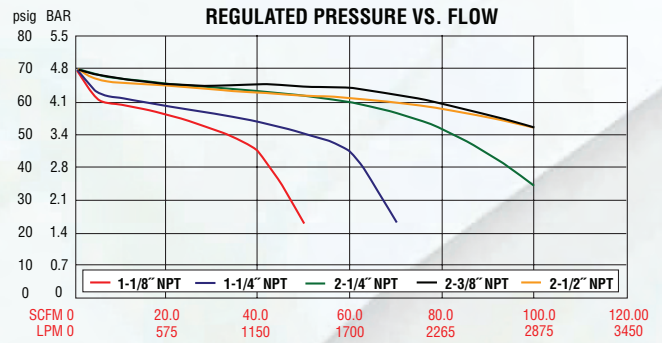

Filters - Regulators & Filters-Regulators-Lubricators

Function	FR					Filter - Regulator
	FRL					Filter - Regulator - Lubricator
Body Style	1					1 Size
	2					2 Size
		-				
Process Connection			1			1/8" NPT (1 Size only)
			2			1/4" NPT
			3			3/8" NPT (2 Size only)
			4			1/2" NPT (2 Size only)
Pressure Range				010		0-10 psi outlet pressure
				030		0-30 psi outlet pressure
				060		0-60 psi outlet pressure
				120		0-120 psi outlet pressure
Filtration					50	50 micron filter
					25	25 micron filter
					05	5 micron filter
Drain					M	Manual drain (standard)
					S	Semi-Automatic drain
					A	Automatic drain (2 Series only)

Introduction to Stainless Steel Fitting Line

The Dwyer Series A-1000 quality tube fittings have been designed and manufactured to provide reliable leak-free connections in a wide variety of applications. A reliable leak-free tubing system will be achieved by combining the proper selection and handling of tubing with the proper tube fitting selection and installation. The following information is provided to assist in the tube selection process.

Material

The tubing material chosen must be compatible with the system's contained media, pressure and temperature, as well as with the environment in which it will be installed. Also, the tubing and fittings materials should be similar for optimum sealing action to occur (stainless fittings for stainless tube, brass fittings for copper tube, carbon steel fittings for carbon steel tube, etc.). The mixing and contact of dissimilar materials may leave the system susceptible to galvanic corrosion and/or not allow proper tube fitting makeup to be achieved.

Pressure and Flow

The size of the tube's outside diameter (O.D.) and the necessary wall thickness are determined by the system's pressure and flow requirements. Table A details the suggested tubing sizes and wall thickness for use with instrumentation tube fittings. If no pressure is shown on the table for a particular size, the tube is not recommended for use with instrumentation tube fittings. The tubing system should not be utilized above the tube's maximum allowable working pressure.

Temperature

The system's operating temperature may affect the initial choice of tubing material and may also affect the maximum allowable working temperature for the given tube size (see Table B for temperature stress factors).

Light Gas Service

To provide a successful connection for light gas service, the tubing must have a thick enough wall to provide resistance for the setup action of the ferrules to further compensate for the tube's potential surface condition.

Handling and Installation

Surface scratches and gouges on tubing are a source of potential leaks. Some precaution when handling the tubing can help reduce surface scratches and maintain the surface finish as originally intended by the manufacturer. Tubing should never be dragged across rocks, blacktop, pavement, or tubing storage racks as scratches and gouges can occur. Sharp blades should always be used in the tube cutters or hacksaws used to cut the tubing so as to provide a clean, square cut. Dull cutting blades can cause internal and external hanging burrs, and cause the tubing to become oval and affect proper insertion within the fitting. As a good handling practice, tubing should always be deburred prior to tube fitting installation to help assure easy and complete tube insertion. Additionally, for bent tube assemblies, it is important to bend tubing prior to installing tube fittings, and to provide a sufficient straight length of tubing after the bend to allow the tube to be fully inserted into the fitting. Also, to eliminate weight stress from the tubing upon the fitting and to provide additional system support for vibration and thermal shock resistance, the tubing should always be supported by tube hangers, clamps or trays.

Stress Factors For Determining Tubing Pressure Ratings at Elevated Temperatures - TABLE B

Temperature		Stainless Steel 316
°F	°C	
100	38	1.00
200	93	1.00
300	149	1.00
400	200	.97
500	260	.90
600	316	.85
700	371	.82
800	427	.80*
900	482	.78*
1000	538	.73*
1200	649	.37*

*The precipitation of chromium carbides potentially resulting in intergranular corrosion may occur when exposed to operating temperatures.

STAINLESS STEEL TUBING - TABLE A
Maximum Allowable Working Pressure (PSIG)

Tube O.D. [Size (in)]	Wall Thickness of Tube (Inches)															
	.010	.012	.014	.016	.020	.028	.035	.049	.065	.083	.095	.109	.120	.134	.156	.188
1/16	5600	6850	8150	9500	12100											
1/8						8550	11000									
3/16						5450	7000	10300								
1/4						4000	5100	7500	10300							
5/16							4050	5850	8050							
3/8							3300	4800	6550							
1/2							2450	3500	4750	6250						
5/8								2950	4000	5200	6050					
3/4								2400	3300	4250	4950	5800				
7/8								2050	2800	3600	4200	4850				
1									2400	3150	3650	4200	4700			
1-1/4										2450	2850	3300	3650	4150	4900	
1-1/2											2350	2700	3000	3400	4000	4900
2												2000	2200	2500	2900	3600

Series A-1000 Stainless Steel Fitting Line

Series A-1001 Male Elbow Fitting Line

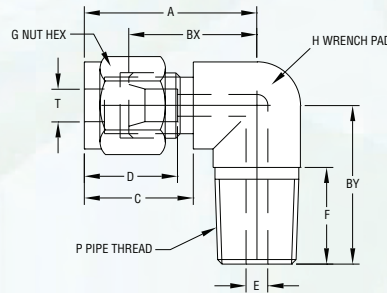

SPECIFICATIONS

Service: Liquid, steam and compatible gases.

Wetted Materials: 316 SS.

Temperature Ranges: See reference Table B.

Pressure Ranges: See reference Table A.

Connections: 1/16" to 1-1/2".

Dimensions: Consult website, or contact factory.

Model	T=Tube O.D.	P=Pipe Thread Male	Model	T=Tube O.D.	P=Pipe Thread Male	Model	T=Tube O.D.	P=Pipe Thread Male
A-1001-1	1/16"	1/16"	A-1001-12	5/16"	1/8"	A-1001-24	5/8"	3/8"
A-1001-2	1/16"	1/8"	A-1001-13	5/16"	1/4"	A-1001-25	5/8"	1/2"
A-1001-3	1/8"	1/16"	A-1001-14	3/8"	1/8"	A-1001-26	5/8"	3/4"
A-1001-4	1/8"	1/8"	A-1001-15	3/8"	1/4"	A-1001-27	3/4"	1/2"
A-1001-5	1/8"	1/4"	A-1001-16	3/8"	3/8"	A-1001-28	3/4"	3/4"
A-1001-6	3/16"	1/8"	A-1001-17	3/8"	1/2"	A-1001-29	7/8"	3/4"
A-1001-7	3/16"	1/4"	A-1001-18	3/8"	3/4"	A-1001-30	1"	3/4"
A-1001-8	1/4"	1/8"	A-1001-19	1/2"	1/4"	A-1001-31	1"	1"
A-1001-9	1/4"	1/4"	A-1001-20	1/2"	3/8"	A-1001-32	1-1/4"	1-1/4"
A-1001-10	1/4"	3/8"	A-1001-21	1/2"	1/2"	A-1001-33	1-1/2"	1-1/2"
A-1001-11	1/4"	1/2"	A-1001-22	1/2"	3/4"			
			A-1001-23	1/2"	3/4"			

Series A-1002 Male Connector Fitting Line

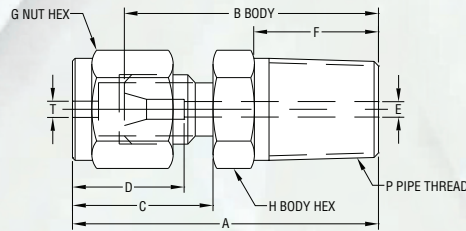

SPECIFICATIONS

Service: Liquid, steam and compatible gases.

Wetted Materials: 316 SS.

Temperature Ranges: See reference Table B.

Pressure Ranges: See reference Table A.

Connections: 1/16" to 2".

Dimensions: Consult website, or contact factory.

Model	T=Tube O.D.	P=Pipe Thread Male	Model	T=Tube O.D.	P=Pipe Thread Male	Model	T=Tube O.D.	P=Pipe Thread Male
A-1002-1	1/16"	1/16"	A-1002-17	5/16"	1/8"	A-1002-32	5/8"	1/2"
A-1002-2	1/16"	1/8"	A-1002-18	5/16"	1/4"	A-1002-33	5/8"	3/4"
A-1002-3	1/16"	1/4"	A-1002-19	5/16"	3/8"	A-1002-34	3/4"	1/2"
A-1002-4	1/8"	1/16"	A-1002-20	3/8"	1/8"	A-1002-35	3/4"	3/4"
A-1002-5	1/8"	1/8"	A-1002-21	3/8"	1/4"	A-1002-36	3/4"	1"
A-1002-6	1/8"	1/4"	A-1002-22	3/8"	3/8"	A-1002-37	7/8"	3/4"
A-1002-7	1/8"	3/8"	A-1002-23	3/8"	1/2"	A-1002-39	1"	1/2"
A-1002-8	1/8"	1/2"	A-1002-24	3/8"	3/4"	A-1002-40	1"	3/4"
A-1002-9	3/16"	1/8"	A-1002-25	1/2"	1/8"	A-1002-41	1"	1"
A-1002-10	3/16"	1/4"	A-1002-26	1/2"	1/4"	A-1002-42	1-1/4"	1"
A-1002-11	1/4"	1/16"	A-1002-27	1/2"	3/8"	A-1002-43	1-1/4"	1-1/4"
A-1002-12	1/4"	1/8"	A-1002-28	1/2"	1/2"	A-1002-44	1-1/2"	1-1/2"
A-1002-13	1/4"	1/4"	A-1002-29	1/2"	3/4"	A-1002-45	2"	2"
A-1002-14	1/4"	1/2"	A-1002-30	5/8"	3/8"			
A-1002-15	1/4"	3/4"	A-1002-31	5/8"	1/2"			

Series A-1000 Stainless Steel Fitting Line

Series A-1003 Union Fitting Line

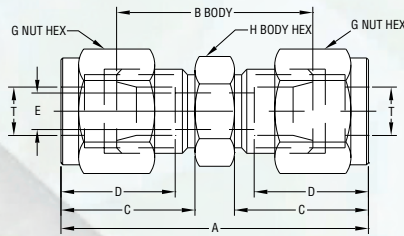

SPECIFICATIONS

Service: Liquid, steam and compatible gases.

Wetted Materials: 316 SS.

Temperature Ranges: See reference Table B.

Pressure Ranges: See reference Table A.

Connections: 1/16" to 2".

Dimensions: Consult website, or contact factory.

Model	T=Tube O.D.	Model	T=Tube O.D.	Model	T=Tube O.D.
A-1003-1	1/16"	A-1003-6	3/8"	A-1003-11	1"
A-1003-2	1/8"	A-1003-7	1/2"	A-1003-12	1-1/4"
A-1003-3	3/16"	A-1003-8	5/8"	A-1003-13	1-1/2"
A-1003-4	1/4"	A-1003-9	3/4"	A-1003-14	2"
A-1003-5	5/16"	A-1003-10	7/8"		

Series A-1004 Union Elbow Fitting Line

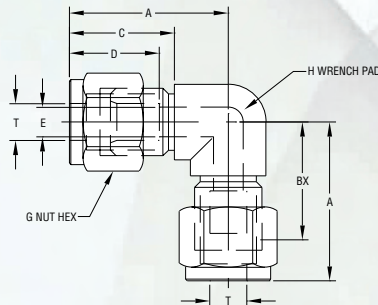

SPECIFICATIONS

Service: Liquid, steam and compatible gases.

Wetted Materials: 316 SS.

Temperature Ranges: See reference Table B.

Pressure Ranges: See reference Table A.

Connections: 1/16" to 2".

Dimensions: Consult website, or contact factory.

Model	T=Tube O.D.	Model	T=Tube O.D.	Model	T=Tube O.D.
A-1004-1	1/16"	A-1004-6	3/8"	A-1004-11	1"
A-1004-2	1/8"	A-1004-7	1/2"	A-1004-12	1-1/4"
A-1004-3	3/16"	A-1004-8	5/8"	A-1004-13	1-1/2"
A-1004-4	1/4"	A-1004-9	3/4"	A-1004-14	2"
A-1004-5	5/16"	A-1004-10	7/8"		

Series A-1005 Union Tee Fitting Line

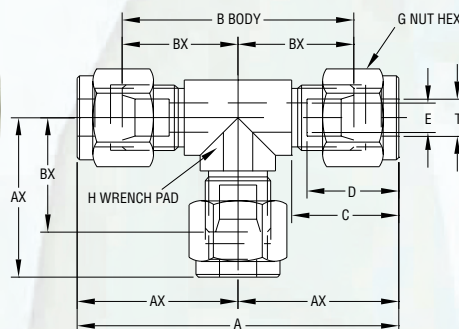

SPECIFICATIONS

Service: Liquid, steam and compatible gases.

Wetted Materials: 316 SS.

Temperature Ranges: See reference Table B.

Pressure Ranges: See reference Table A.

Connections: 1/16" to 2".

Dimensions: Consult website, or contact factory.

Model	T=Tube O.D.	Model	T=Tube O.D.	Model	T=Tube O.D.
A-1005-1	1/16"	A-1005-6	3/8"	A-1005-12	1-1/4"
A-1005-2	1/8"	A-1005-7	1/2"	A-1005-13	1-1/2"
A-1005-3	3/16"	A-1005-8	5/8"	A-1005-14	2"
A-1005-4	1/4"	A-1005-9	3/4"		
A-1005-5	5/16"	A-1005-11	1"		

Series A-1006 Front Ferrule Fitting Line

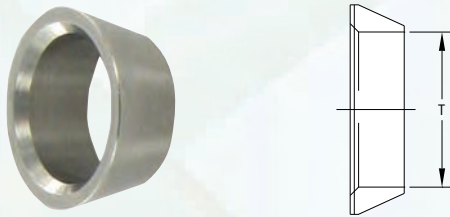

SPECIFICATIONS

Service: Liquid, steam and compatible gases.

Wetted Materials: 316 SS.

Temperature Ranges: See reference Table B.

Pressure Ranges: See reference Table A.

Connections: 1/16" to 2".

Model	T=Tube O.D.	Model	T=Tube O.D.
A-1006-1	1/16"	A-1006-8	5/8"
A-1006-2	1/8"	A-1006-9	3/4"
A-1006-3	3/16"	A-1006-10	7/8"
A-1006-4	1/4"	A-1006-11	1"
A-1006-5	5/16"	A-1006-12	1-1/4"
A-1006-6	3/8"	A-1006-13	1-1/2"
A-1006-7	1/2"	A-1006-14	2"

Series A-1007 Back Ferrule Fitting Line

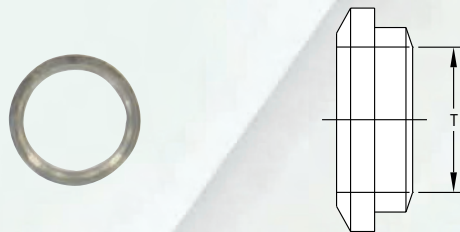

SPECIFICATIONS

Service: Liquid, steam and compatible gases.

Wetted Materials: 316 SS.

Temperature Ranges: See reference Table B.

Pressure Ranges: See reference Table A.

Connections: 1/16" to 2".

Model	T=Tube O.D.	Model	T=Tube O.D.
A-1007-1	1/16"	A-1007-8	5/8"
A-1007-2	1/8"	A-1007-9	3/4"
A-1007-3	3/16"	A-1007-10	7/8"
A-1007-4	1/4"	A-1007-11	1"
A-1007-5	5/16"	A-1007-12	1-1/4"
A-1007-6	3/8"	A-1007-13	1-1/2"
A-1007-7	1/2"	A-1007-14	2"

Series A-1008 Nut Fitting Line

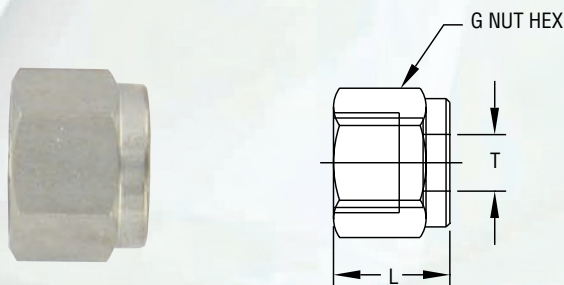

SPECIFICATIONS

Service: Liquid, steam and compatible gases.

Wetted Materials: 316 SS.

Temperature Ranges: See reference Table B.

Pressure Ranges: See reference Table A.

Connections: 1/16" to 2".

Dimensions: Consult website, or contact factory.

Model	T=Tube O.D.	Model	T=Tube O.D.
A-1008-1	1/16"	A-1008-8	5/8"
A-1008-2	1/8"	A-1008-9	3/4"
A-1008-3	3/16"	A-1008-10	7/8"
A-1008-4	1/4"	A-1008-11	1"
A-1008-5	5/16"	A-1008-12	1-1/4"
A-1008-6	3/8"	A-1008-13	1-1/2"
A-1008-7	1/2"	A-1008-14	2"

Series A-1000 Stainless Steel Fitting Line

Series A-1009 Ferrule Set Fitting Line

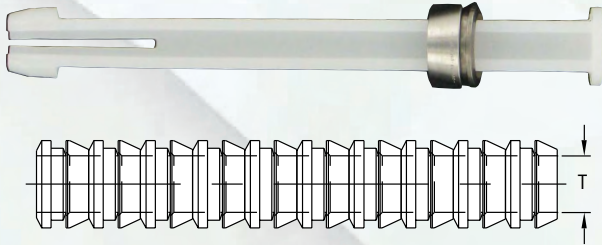

SPECIFICATIONS

Service: Liquid, steam and compatible gases.

Wetted Materials: 316 SS.

Temperature Ranges: See reference Table B.

Pressure Ranges: See reference Table A.

Connections: 1/16" to 2".

Model	T=Tube O.D.	Model	T=Tube O.D.	Model	T=Tube O.D.
A-1009-1	1/16"	A-1009-4	1/4"	A-1009-6	3/8"
A-1009-2	1/8"	A-1009-5	5/16"	A-1009-7	1/2"
A-1009-3	3/16"				

Series A-1010 Bulkhead Union Fitting Line

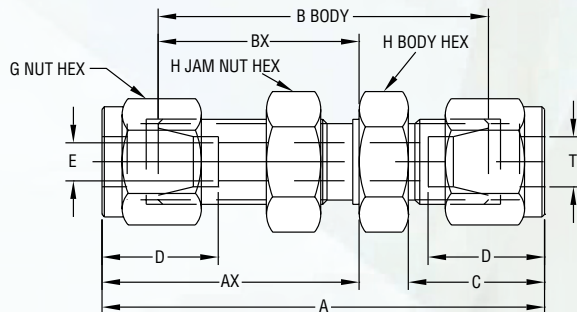
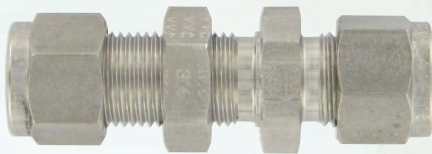

SPECIFICATIONS

Service: Liquid, steam and compatible gases.

Wetted Materials: 316 SS.

Temperature Ranges: See reference Table B.

Pressure Ranges: See reference Table A.

Connections: 1/16" to 1".

Dimensions: Consult website, or contact factory.

Model	T=Tube O.D.
A-1010-1	1/16"
A-1010-2	1/8"
A-1010-3	3/16"
A-1010-4	1/4"
A-1010-5	5/16"
A-1010-6	3/8"
A-1010-7	1/2"
A-1010-8	5/8"
A-1010-9	3/4"
A-1010-10	1"

Series A-1011 Female Connector Fitting Line

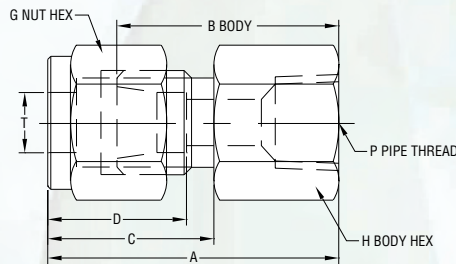

SPECIFICATIONS

Service: Liquid, steam and compatible gases.

Wetted Materials: 316 SS.

Temperature Ranges: See reference Table B.

Pressure Ranges: See reference Table A.

Connections: 1/16" to 1-1/2".

Dimensions: Consult website, or contact factory.

Model	T=Tube O.D.	P=Pipe Thread Male	Model	T=Tube O.D.	P=Pipe Thread Male	Model	T=Tube O.D.	P=Pipe Thread Male
A-1011-1	1/16"	1/16"	A-1011-11	5/16"	1/4"	A-1011-21	5/8"	3/8"
A-1011-2	1/16"	1/8"	A-1011-12	3/8"	1/8"	A-1011-22	5/8"	1/2"
A-1011-3	1/8"	1/8"	A-1011-13	3/8"	1/4"	A-1011-23	3/4"	1/2"
A-1011-4	1/8"	1/4"	A-1011-14	3/8"	3/8"	A-1011-24	3/4"	3/4"
A-1011-5	3/16"	1/8"	A-1011-15	3/8"	1/2"	A-1011-25	7/8"	3/4"
A-1011-6	1/4"	1/8"	A-1011-16	3/8"	3/4"	A-1011-26	1"	3/4"
A-1011-7	1/4"	1/4"	A-1011-17	1/2"	1/4"	A-1011-27	1"	1"
A-1011-8	1/4"	3/8"	A-1011-18	1/2"	3/8"	A-1011-28	1-1/4"	1-1/4"
A-1011-9	1/4"	1/2"	A-1011-19	1/2"	1/2"	A-1011-29	1-1/2"	1-1/2"
A-1011-10	5/16"	1/8"	A-1011-20	1/2"	3/4"			



A-2018



A-2019



A-2020

Stainless Steel Fittings

Our stainless steel fittings and pipe nipples are made from 304 or 316 SS and are rated at 150 psi.

Series A-2018 316 SS Hose Barb: Male Pipe Thread

Model No.	Male NPT x HB
A-2018-1	1/4" x 1/4"
A-2018-2	1/4" x 3/8"

Series A-2019 Cap: Female Pipe Thread

Model No.	Female NPT
A-2019-1	1/8"
A-2019-2	1/4"
A-2019-3	3/8"
A-2019-4	1/2"
A-2019-5	3/4"
A-2019-6	1"

Series A-2020 Cross: Female Pipe Thread

Model No.	Female NPT
A-2020-1	1/8"
A-2020-2	1/4"
A-2020-3	3/8"
A-2020-4	1/2"
A-2020-5	3/4"
A-2020-6	1"



A-2021



A-2022



A-2023



A-2024

Series A-2021 Coupling: Female Pipe Thread

Model No.	Female NPT
A-2021-1	1/8" x 1/8"
A-2021-2	1/4" x 1/4"
A-2021-3	3/8" x 3/8"
A-2021-4	1/2" x 1/2"
A-2021-5	3/4" x 3/4"
A-2021-6	1" x 1"
A-2021-7	1-1/4" x 1-1/4"
A-2021-8	1-1/2" x 1-1/2"
A-2021-9	2" x 2"
A-2021-10	3" x 3"

Series A-2022 Elbow: Female Pipe Thread, 90°

Model No.	Female NPT
A-2022-1	1/8" x 1/8"
A-2022-2	1/4" x 1/4"
A-2022-3	3/8" x 3/8"
A-2022-4	1/2" x 1/2"
A-2022-5	3/4" x 3/4"
A-2022-6	1" x 1"
A-2022-7	1-1/4" x 1-1/4"
A-2022-8	1-1/2" x 1-1/2"
A-2022-9	2" x 2"
A-2022-10	3" x 3"

Series A-2023 Elbow: Female Pipe Thread, 45°

Model No.	Female NPT
A-2023-1	1/8" x 1/8"
A-2023-2	1/4" x 1/4"
A-2023-3	3/8" x 3/8"
A-2023-4	1/2" x 1/2"
A-2023-5	3/4" x 3/4"
A-2023-6	1" x 1"
A-2023-7	1-1/4" x 1-1/4"
A-2023-8	1-1/2" x 1-1/2"
A-2023-9	2" x 2"
A-2023-10	3" x 3"

Series A-2024 Reducer Bushings

Model No.	Male NPT x Female NPT
A-2024-1	1/4" x 1/8"
A-2024-2	3/8" x 1/4"
A-2024-3	1/2" x 1/4"
A-2024-4	1/2" x 3/8"
A-2024-5	3/4" x 1/4"
A-2024-6	3/4" x 1/2"
A-2024-7	1" x 1/2"
A-2024-8	1" x 3/4"
A-2024-9	1-1/4" x 3/4"
A-2024-10	1-1/4" x 1"
A-2024-11	1-1/2" x 3/4"
A-2024-12	1-1/2" x 1"
A-2024-13	1-1/2" x 1-1/4"
A-2024-14	2" x 1"
A-2024-15	2" x 1-1/4"
A-2024-16	2" x 1-1/2"
A-2024-17	3" x 2"



A-2025

Series A-2025 Street Elbow: Female Pipe Thread by Male Pipe Thread

Model No.	Female NPT x Male NPT
A-2025-1	1/8" x 1/8"
A-2025-2	1/4" x 1/4"
A-2025-3	3/8" x 3/8"
A-2025-4	1/2" x 1/2"
A-2025-5	3/4" x 3/4"
A-2025-6	1" x 1"
A-2025-7	1-1/4" x 1-1/4"
A-2025-8	1-1/2" x 1-1/2"
A-2025-9	2" x 2"
A-2025-10	3" x 3"

Series A-2026 Tee: Female Pipe Thread

Model No.	Female NPT
A-2026-1	1/8"
A-2026-2	1/4"
A-2026-3	3/8"
A-2026-4	1/2"
A-2026-5	3/4"
A-2026-6	1"
A-2026-7	1-1/4"
A-2026-8	1-1/2"
A-2026-9	2"
A-2026-10	3"



A-2026

Series A-2027 Union: Female Pipe Thread

Model No.	Female NPT
A-2027-1	1/8"
A-2027-2	1/4"
A-2027-3	3/8"
A-2027-4	1/2"
A-2027-5	3/4"
A-2027-6	1"
A-2027-7	1-1/4"
A-2027-8	1-1/2"
A-2027-9	2"
A-2027-10	3"



A-2027



A-2028

Series A-2028 Nipple: Male Pipe Thread

Model No.	Male NPT x Length	Model No.	Male NPT x Length
A-2028-1	1/8" x 3/4"	A-2028-15	3/4" x 2"
A-2028-2	1/8" x 1-1/2"	A-2028-16	1" x 1-1/2"
A-2028-3	1/8" x 2"	A-2028-17	1" x 2"
A-2028-4	1/4" x 7/8"	A-2028-18	1-1/4" x 1-5/8"
A-2028-5	1/4" x 1-1/2"	A-2028-19	1-1/4" x 2"
A-2028-6	1/4" x 2"	A-2028-20	1-1/2" x 1-3/4"
A-2028-7	3/8" x 1"	A-2028-21	1-1/2" x 2"
A-2028-8	3/8" x 1-1/2"	A-2028-22	2" x 2"
A-2028-9	3/8" x 2"	A-2028-23	2" x 2-1/2"
A-2028-10	1/2" x 1-1/8"	A-2028-24	3" x 2-5/8"
A-2028-11	1/2" x 1-1/2"	A-2028-25	3" x 3"
A-2028-12	1/2" x 2"	A-2028-26	4" x 2-7/8"
A-2028-13	3/4" x 1-3/8"	A-2028-27	4" x 4"
A-2028-14	3/4" x 1-1/2"		

Index by Product

Product	Section	Page No.	Product	Section	Page No.
160	Particulate/Air Velocity	72	DCT600	Timer-Controllers	14
1900	Pressure Switches	36	DCV	Valves	83, 85
1950	Pressure Switches	37	DH	Pressure Switches	34-35
2000	Pressure Gages	17	DHII	Pressure Switches	33
2-5000	Pressure Gages	18	DH3	Pressure Switches	32
3000MR	Pressure Switches	30	DM-2000	Pressure Transmitters	44
3000MRS	Pressure Switches	30	DPG-100	Pressure Gages	25
471	Particulate/Air Velocity	70	DPG-200	Pressure Gages	27
475-AV Kit	Particulate/Air Velocity	71	DPGA	Pressure Gages	26
477-AV Kit	Particulate/Air Velocity	71	DPGW	Pressure Gages	26
605	Pressure Transmitters	45	DPM	Particulate/Air Velocity	68
608	Pressure Transmitters	39	DS	Pressure Switches	38
616C	Pressure Transmitters	42	DSGT	Pressure Gages	28
616OT	Pressure Transmitters	42	DSS	Speed Sensors	76
616W	Pressure Transmitters	43	DV	Valves	90
626	Pressure Transmitters	46-47	FDT	Pressure Transmitters	49
628	Pressure Transmitters	46-47	FR	Accessories	98-101
641	Particulate/Air Velocity	75	FRL	Accessories	98-101
641B	Particulate/Air Velocity	73	IPV	Level/Vibrators	65
641RM	Particulate/Air Velocity	74	IS626	Pressure Transmitters	48
651	Temperature/Power	79	LTC	Level/Vibrators	58
659	Temperature/Power	79	LTS	Level/Vibrators	58
763	Pressure Gages	23	MP	Pressure Switches	31
764	Pressure Gages	23	MS	Pressure Transmitters	40-41
A-1000	Accessories	102-106	Muffler Accessory	Valves	86
A-2000	Accessories	107-108	NSS	Speed Sensors	77-78
A3000	Pressure Switches	29	PLS	Level/Vibrators	50-51
ABFV	Valves	94-96	PMS	Particulate/Air Velocity	67
ABV	Valves	91	PMT	Particulate/Air Velocity	69
APV	Level/Vibrators	66	PRV	Level/Vibrators	63
BFV	Valves	93	PS	Level/Vibrators	59
BHC	Valves	89	PTV	Level/Vibrators	64
BPV	Level/Vibrators	62	QV	Valves	97
BT	Temperature/Power	80	RDCV	Valves	83-84
BV2MB	Valves	90	RSV	Valves	86
CLS1	Level/Vibrators	60	RTD	Temperature/Power	80
CLS2	Level/Vibrators	52-53	SGD	Pressure Gages	21
CRF2	Level/Vibrators	61	SGF	Pressure Gages	19
CS	Temperature/Power	81	SGL	Pressure Gages	20
CVA	Valves	92	SGS	Pressure Gages	22
DA	Pressure Switches	38	SGT	Pressure Gages	21
DBLM	Level/Vibrators	59	SGX	Pressure Gages	19
DCD	Valves	89	SVE	Valves	87
DCT1000	Timer-Controllers	10-11	TFLS	Level/Vibrators	57
DCT1000DC	Timer-Controllers	12	TPG	Pressure Gages	24
DCT500A	Timer-Controllers	13	Ultra-Mag™ Switch	Level/Vibrators	54-56
DCT500ADC	Timer-Controllers	13	UPA-130	Temperature/Power	81

Index by Category

Accessories			Lubricators	98-101
Fittings		102-108	Magnehelic®	17, 45
Air Flow			Magnesense®	40-41
Gages		17-18	Minihelic®	18
Air Velocity			Mini-Photohelic®	31
Indicators		70-71	Mother Node™	34-35
Meters		70-71	One-Touch™	42
Test Kits		71	Photohelic®	29
Transmitters		73-75	Pitot Tubes	72
Anemometers		70	Position Indicating Controls	97
Bin Level			Pressure	
Switches		50-60	Gages	19-26
Connectors		89	Switch/Gages	29-35
Controllers			Switches	27, 36-38
Dust Collection		10-14	Transmitters	27, 39-49
Level		58	Quick-View®	97
Detector		67-69	Regulators	98-101
Differential Pressure			RTD Sensors	80
Gages		17-18	Sensors	
Indicating Transmitters	32-35, 40-41, 44-45		Broken Bag	67-69
Indicators		17-18	Particulate	67-69
Switch/Gages		29-35	Speed	76-78
Switches		36-37	Temperature	79-80
Transmitters		39-45	Speed Sensors	76-78
Digihelic®		32-35	Switch/Gages	29-35
Digital Indicating			Switches	
Pressure Transmitters	27-28, 32-35, 40-41, 44-45		Bin Level	50-60
Process/Temperature Controls		28	Current	81
Dust Collector Timer Controls		10-14	Differential Pressure	36-37
Explosion-Proof			Level	50-60
Bin Level Switches	50-51, 54-56		Limit-Pressure	27, 36-38
Differential Pressure Switches	36-37		Liquid Level	52-53, 60
Position Indicator Switches/Transmitters	97		Single Pressure	27, 38
Pressure Switches	38		Speed	76-78
Filters		98-101	Valve Position	97
Fittings		89	Temperature	
Flow			Indicators	80
Gages		17-18	Sensors	80
Gages			Thermometers	80
Differential Pressure	17-18		Transmitters	79
Pressure	19-26		Test Kits	
Temperature	80		Air Velocity	71
Handheld Instruments			Thermal Anemometers	70
Air Velocity	70-71		Thermometers	
Indicators			Bi-Metal	80
Differential Pressure	17-18		Direct	80
Process	81		Transmitters	
Temperature	80		Air Velocity	73-75
Valve Position	97		Differential Pressure	39-45
Kits			Level	61
Air Velocity	71		Particulate	69
Repair	89		Pressure Indicating	45
Leak Detectors	67-69		Single Pressure	27-28, 46-49
Level			Temperature	79
Controllers	58		Ultra-Mag™	54-56
Controls	50-60		Valves	
Switches	50-60		Ball	90-91
Transmitters	61		Butterfly	93-96
Limit Switches			Drain	90
Differential Pressure	36-37		Piston	92
Level	50-60		Position Indicator/Switch/Transmitter	97
Pressure	27, 36-38		Pulse	82-85
Liquid Level			Solenoid	86-87
Controllers	58		Vibrators	62-66
Switches	52-53, 60			
Transmitters	61			

Level Products Bulk Density Table

The following information is useful when specifying paddle switches and pressure sensitive diaphragm switches for dry product applications.

MATERIAL	Ave. Bulk Density (lbs./cu.ft.)		
Acid Phosphate, pulv	60	Earth, common loam, dry	75
Alum, lumpy	50-60	Earth, common loam, moist	85
Alum, pulv	45-50	Earth, Mud, fluid	110
Aluminum Oxide	120	Earth, Diatomaceous	10-15
Asbestos, ground	15	Feldspar, lumps	90-100
Asbestos, shredded	20-25	Feldspar, ground	65-70
Asbestos, solid	150	Feldspar, powdered (-100M)	75
Ashes, dry, loose	38	Fire Brick (1/4" x 0')	85
Ashes, wet, loose	47	Flaxseed	45
Asphalt, crushed	45	Flint, pebbles	105
Attapulgus clay	24	Flour	35
Bagasse	7.5	Fluorspar, lumps	110-125
Baking Powder	56	Fluorspar, ground (100 mesh 10)	80-85
Bakelite, powdered	35	Fuller's Earth, dry	30-35
Barytes	180-216	Fuller's Earth, oily	60
Bauxite, crushed	75-85	Garbage, average	30
Beans, castor	36	Glass Batch	90-100
Bones, crushed	40	Gneiss, lumps	96
Bones, ground, dry	50	Grains:	
Borax	105-110	Barley (48# bu.)	38
Bran	16	Corn, shelled (56# bu.)	45
Brewers Grain, dry	28	Flour, wheat (196# bu.)	35-40
Brewers Grain, wet	55	Oats (32# bu.)	26
Calcium Carbide, crushed	75-80	Rye (56# bu.)	44
Carbon, activated, fine, dry	8-20	Wheat (60# bu.)	48
Carbon Black Pellets	24-28	Granite, lumps	96
Cement Clinker	75-80	Granite, crushed (1-1/4"x10")	100
Cement, Portland, aerated	65	Gravel, mixed sizes	96-100
Cement, Portland, packed	95	Greenstone, lumps	107
Chalk, crushed	85-90	Gypsum, lumps	90-95
Charcoal, lump	15-30	Gypsum, crushed	90-95
Charcoal, ground	10	Gypsum, ground	50-56
Cinders, blast furnace	57	Ice, broken	40
Cinders, coal, ashes & clinker	40	Ice, solid	57
Clay, dry lump	63	Iron Ore, loose	125-150
Coal, Anthracite ROM	55-60	Iron Pellets	128
Coal, Anthracite, solid	97	Lead Ore, galena, solid	465
Coal, Bituminous ROM	50	Lignite, air dried	45-50
Coal, Bituminous, solid	85	Lime, hydrated - 200 mesh	20-25
Coffee Beans	25	Lime, quick, lump	70-80
Coke Breeze	30-35	Lime, quick, ground	65
Coke, lump, average	28-32	Limestone, lumps	90-95
Concrete Mix	125-150	Limestone, ground, coarse	85
Copper Ore	125-150	Limestone, ground, fine	65-70
Cork, solid	15	Malt, Whole, dry	20-30
Cork, ground	4-5	Malt, wet	60-65
Cottonseed, dry	25	Manganese Ore	140
Cottonseed, meal	38	Marble, crushed	95
Cullet, glass, average	85-100	Milk powder	35
Dolomite, calcined	40	Molybdenum concentrates	115
Dolomite, crushed	95-100	Oyster Shells	60
		Paper Pulp Stock	60
		Peanuts	40
		Phosphate Rock, lumps	90
		Phosphate Super	70
		Potash (1-1/2" x 1-1/2")	70
		Quartz, lumps	100-110
		Resin, Vinyl	25-35
		Rice, hulled	45
		Rice, rough	36
		Rubber, ground	24
		Rubber, shredded scrap	46
		Salt Cake, coarse	75-95
		Salt Cake, fine	65-85
		Salt, coarse	50
		Salt, fine	75
		Salt peter	80
		Sand, Foundry	90-95
		Sand, dry, loose	90-95
		Sand, wet, loose	105-110
		Sand & Gravel, dry	90-105
		Sand & Gravel, wet	105-125
		Sandstone, lumps	82-86
		Sawdust, dry	7-12
		Scale, Rolling Mill	125
		Sewage, Screenings, drained	55
		Sewage, Sludge, raw	65
		Shale, crushed	92
		Shot, steel	250
		Silica, Flour	65
		Slag, bank, crushed	80
		Slag, furnace, granulated	60-65
		Soap chips	5-15
		Soap powder	20-25
		Soda Ash, dense	60-62
		Soda Ash, light	28-32
		Soda, Bicarbonate	50-58
		Soybeans, cracked	32-36
		Soybeans, whole	48
		Soybean cake	40-45
		Soybean flour	27
		Soybean meal	40
		Steel turnings	20-30
		Stone, crushed	85-105
		Sugar Cane	15-20
		Sugar, raw	55-65
		Sulphur, lump	75-85
		Sulphur, powder	50-55
		Tanbark, ground	55
		Tobacco	15-25
		Trap Rock, crushed	95-105
		Tungsten Carbide, powder	250
		White Lead	75
		Wood Chips	8-15
		Wood Flour	20-25
		Zinc Oxide, crushed	160
		Zinc Oxide	35

Discount Schedule and Conditions of Sale

Dwyer Instruments, Inc. - Discount Schedule

Note:	Industrial Discount Schedule*		
	Quantity of Each Item	Discounts	
		Standard	Schedule B
Each item (model, range, part number, etc.) is discounted independently. In an order for more than one item, different items cannot be combined to earn a greater discount. Most items are subject to STANDARD schedule at right. Prices followed by the symbol (®) are subject to discounts per schedule B. Certain items such as repairs, repair parts, EXPL and WP housings, prices followed by the symbol (®), special scale and tag charges are priced at net and earn no discount.	1-24	Net	Net
	25-99	5%	Net
	100-249	10%	5%
	250-499	15%	10%
	500-Up	20%	15%

*Please contact us for discount schedules for other account types.

Dwyer Instruments, Inc. - Standard Terms and Conditions of Sale

- Prices and Specifications** are subject to change without notice.
- Shipping dates** are approximate. They are dependent upon credit approval and subject to delays beyond our control.
- Terms:** Net 30 days to companies with established credit rating. In the event Buyer fails to fulfill previous terms of payment, or in case Seller shall have any doubt at any time as to Buyer's financial responsibility, Seller may decline to make further deliveries except upon receipt of cash in advance or other special arrangements.
- Point and Title:** All material is sold EXW Ex Works Dwyer Instruments, Inc. Title to all material sold shall pass to buyer upon delivery by Seller to carrier at shipping point.
- State and Local Taxes:** Any taxes which the Seller may be required to pay or collect upon or with respect to the sale, purchase, delivery, use or consumption of any of the material covered hereby shall be for the account of the Buyer and shall be added to the purchase price.
- Special tooling,** dies, silk screens and molds acquired specially to produce goods for Buyer remain the property of Dwyer Instruments, Inc., and may not be removed. They will be maintained in good condition for a minimum period of three years from the date of the original purchase order.
- Trade Compliance:** Buyer acknowledges that the products, software, and technology, including technical information and documents (collectively "Items"), of Dwyer Instruments, Inc., are subject to regulation by agencies of the U.S. government including, but not limited to, the U.S. Department of Commerce. Buyer shall comply with the Export Administration Regulations (EAR) and all applicable U.S. laws and regulations regarding the sale, delivery and transfer of said Items. Buyer shall not, without first obtaining the required licenses, authorizations or approvals from the appropriate U.S. government agency; (i) export, re-export, transfer or divert any Item directly or indirectly to any country or national resident thereof, or any person, entity or country that has restrictions imposed upon them by the U.S. government, (ii) engage in, or knowingly sell to any party engaged in activity related to the development, production, use, testing, or maintenance of Weapons of Mass Destruction, including uses related to nuclear, missile, chemical or biological warfare, or (iii) engage in, or knowingly sell to any party engaged in activity related to the development, production, use, or maintenance of any safeguarded or unsafeguarded nuclear fuel facility or components for such facilities. Buyer shall fully cooperate with Seller, without charge, in any official audit or inspection by an authorized agent, official, employee, or accredited representative of the U.S. government. Buyer shall indemnify and hold Seller harmless from, or in connection with, any violation of this Section by Buyer, its employees, consultants, agents, or customers. The obligations, requirements and claims described herein shall survive the expiration of any business relationship with Dwyer Instruments, Inc., including its divisions, subsidiaries and affiliated companies.
- Limited Warranty:** The Seller warrants all Dwyer Instruments and equipment to be free from defects in workmanship or material under normal use and service for a period of one year from date of shipment. Liability under this warranty is limited to repair or replacement EXW Ex Works Dwyer Instruments, Inc. of any parts which prove to be defective within that time or repayment of the purchase price at the Seller's option provided the instruments have been returned, transportation prepaid, within one year from date of purchase. All technical advice, recommendations and services are based on technical data and information which the Seller believes to be reliable and are intended for use by persons having skill and knowledge of the business, at their own discretion. In no case is Seller liable beyond replacement of equipment EXW Ex Works Dwyer Instruments, Inc. or the full purchase price. This warranty does not apply if the maximum ratings label is removed or if the instrument or equipment is abused, altered, used at ratings above the maximum specified, or otherwise misused in any way.
THIS EXPRESS LIMITED WARRANTY IS IN LIEU OF AND EXCLUDES ALL OTHER REPRESENTATIONS MADE BY ADVERTISEMENTS OR BY AGENTS AND ALL OTHER WARRANTIES, BOTH EXPRESS AND IMPLIED. THERE ARE NO IMPLIED WARRANTIES OF MERCHANTABILITY OR OF FITNESS FOR A PARTICULAR PURPOSE FOR GOODS COVERED HEREUNDER.
- Buyer's Remedies:** THE BUYER'S EXCLUSIVE AND SOLE REMEDY ON ACCOUNT OF OR IN RESPECT TO THE FURNISHING OF NON-CONFORMING OR DEFECTIVE MATERIAL SHALL BE TO SECURE REPLACEMENT THEREOF AS AFORESAID. THE SELLER SHALL NOT IN ANY EVENT BE LIABLE FOR THE COST OF ANY LABOR EXPENDED ON ANY SUCH MATERIAL OR FOR ANY SPECIAL, DIRECT, INDIRECT, CONSEQUENTIAL OR INCIDENTAL DAMAGES TO ANYONE BY REASON OF THE FACT THAT IT SHALL HAVE BEEN NON-CONFORMING OR DEFECTIVE.
- Acceptance:** All orders shall be subject to the terms and conditions contained or referred to in the Seller's quotation, acknowledgment, and to those listed here and to no others whatsoever. No waiver, alteration or modification of these terms and conditions shall be binding unless in writing and signed by an executive officer of the Seller. All orders are subject to written acceptance by Dwyer Instruments, Inc., Michigan City, Indiana, U.S.A.

Trademark Acknowledgements

Registered trademarks of Dwyer Instruments, Inc.



Capsuhelic®
CapsuPhotohelic®
Dighelic®
Duotect®
Durablock®
Dwyer Group®
Dwyer®

Flex-Tube®
Flotect®
Iso Verter®
Lin-E-Aire®
Lite Rite®
Love®
Love Controls®

Magnehelic®
MagneSense®
Mercoïd®
Mercoïd Control®
Mercontrol®
Microtector®
Minihelic®

Mini-Master®
Mini-Photohelic®
Optitrol®
Photohelic®
Plast-A-Vane®
Precisor®
Quick-Scan®

Quick-View®
Rate-Master®
Safe-T-Ohm®
Slack Tube®
Spirahelic®
The Low Pressure People®

Trail-Tail®
Visi-Float®

Common law marks of Dwyer Instruments, Inc.



Even-Action™
Hi-Flow™
Loop Alarms™
Lovelink™
Minitactor™
Mother Node™
Pre-Trac™
Proximity™
S-D™
Slide Guide™
SLiquid™
Tell Tale™
Tell Tale Jr.™
Thermoguide™
Ultra-Mag™
Ultra-View™
Vaneometer™

Commonly used marks and graphics



Marks registered to companies other than Dwyer Instruments, Inc.



Underwriters Laboratories, Inc.



Underwriters Laboratories, Inc.



Canadian Standards Association

MasterCard International Inc.



Underwriters Laboratories, Inc.



FM Global Technology



Visa International Services Association

Alumel®
Chromel®
Darina®
Duracell®
Eveready®
Fluorolube®
Freon®

Hoskins Alloys, LLC
Hoskins Alloys, LLC
Shell Oil Company
The Gillette Company
Eveready Battery Company, Inc.
Gabriel Performance Products LLC
E.I. DuPont De Nemours and Company

Open Signal®
Sensorpak®
Sensorpulse®
Swagelock®
Trendreader®
Tygon®
VCR®
Velcro®
Windows®
Windows NT®
Excel®
Powerpoint®
Air Flow™
No More Leaks™
Precision Flow™
ProHood™
Smart Interface™

Easton Controls, Inc.
Easton Controls, Inc.
Easton Controls, Inc.
Swagelock Company
ACR Systems, Inc.
Saint-Gobain Abrasives, Inc.
Swallow Company
Velcro Industries B.V.
Microsoft Corporation
Microsoft Corporation
Microsoft Corporation
TSI, Inc.
Permatex
Sierra Instruments, Inc.
TSI, Inc.
lentek Co., Ltd.

Hirschmann®
HyperTerminal®
Iglide®

Hirschmann Electronics GMBH
Hilgraeve, Inc.
Igus Spritzgussteile für die Industrie GmbH
Huntington Alloys Corporation
General Electric Company
Henkel Corporation
Schneider Automation
Hartwell-Dzus, Inc.
Easton Controls, Inc.

Inconel®
Lexan®
Loctite®
Modbus®
Nylatch®
Open I/O®

Information about Mercury-added Products

Dwyer Instruments, Inc. continues its development of non-mercury replacement alternatives for those products currently offered containing mercury. We will continue to work with all customers to supply mercury added products as needed for replacement of products currently in use and to guide customers towards non-mercury added products for new applications.

Dwyer Instruments, Inc. will comply with all local, state, federal, and international laws regarding the sale of mercury added products. These laws may affect our ability to sell, distribute, or transport products into restricted states and/or countries. Mercury added product sales may be limited or denied to certain customers depending on the location or intended use of the product.

Dwyer Instruments, Inc. encourages all customers to become familiar and comply with all mercury legislation. Sales of any and all mercury added products will be discontinued to any customer that knowingly or willfully disregards any legislation concerning mercury.

Dwyer Instruments, Inc. requests that all mercury containing products are properly disposed of at the end of their useful life. Many web sites are available to help educate consumers about proper disposal of mercury added products. Please visit www.newmoa.org for additional information related to mercury usage.



DWYER INSTRUMENTS, INC.

P.O. Box 373

Michigan City, IN 46361-9986

Return Service Requested

Timer-Controllers

Pressure Gages

Pressure Switches

Pressure Transmitters

Level/Vibrators

Particulate/Air Velocity

Speed Sensors

Temperature/Power

Valves

Accessories



phone: 219/879-8000 | fax: 219/872-9057

www.dwyer-inst.com